



# GENERAL CATALOG 2026



**12**  
PAGE

**METERS  
AND POWER MONITORS**

**ENERGY  
METERING PLAN**

Remote data retrieval from meters  
Energy saving  
ISO 50001  
Energy rebilling

**78**  
PAGE

**NETWORK  
MONITORING  
FROM LOW VOLTAGE  
TO HIGH VOLTAGE**

**NETWORK  
SUPERVISION  
AND PHYSICAL  
MEASUREMENT**

High-accuracy measurement  
Network supervision  
Severe environments  
Multi-function  
Accurate display

**104**  
PAGE

**CURRENT  
TRANSFORMERS  
AND SHUNTS**

**148**  
PAGE

**TRANSDUCERS**

**186**  
PAGE

**PANEL METERS AND  
SYNCHROCOUPLER**

**238**  
PAGE

**AUXILIARY RELAYS**

**CRITICAL AUXILIARY  
RELAYS**

High breaking capacity  
Railway applications  
Nuclear qualification  
Control of critical automated systems  
EMC immunity

**246**  
PAGE

**CIVILIAN AND MILITARY  
NAVAL APPLICATIONS**

**CIVILIAN AND MILITARY  
NAVAL APPLICATIONS**

Anemovane  
Pressure, temperature and humidity sensor  
Temperature sensor  
Multifunction wind repeater  
Data concentration and communication unit

**258**  
PAGE

**SERVICES  
AND TRAINING**

**SERVICES  
AND TRAINING**  
Combined know-how

# THE CHAUVIN ARNOUX GROUP MEASUREMENT EXPERTS

## 6 companies of measurement experts

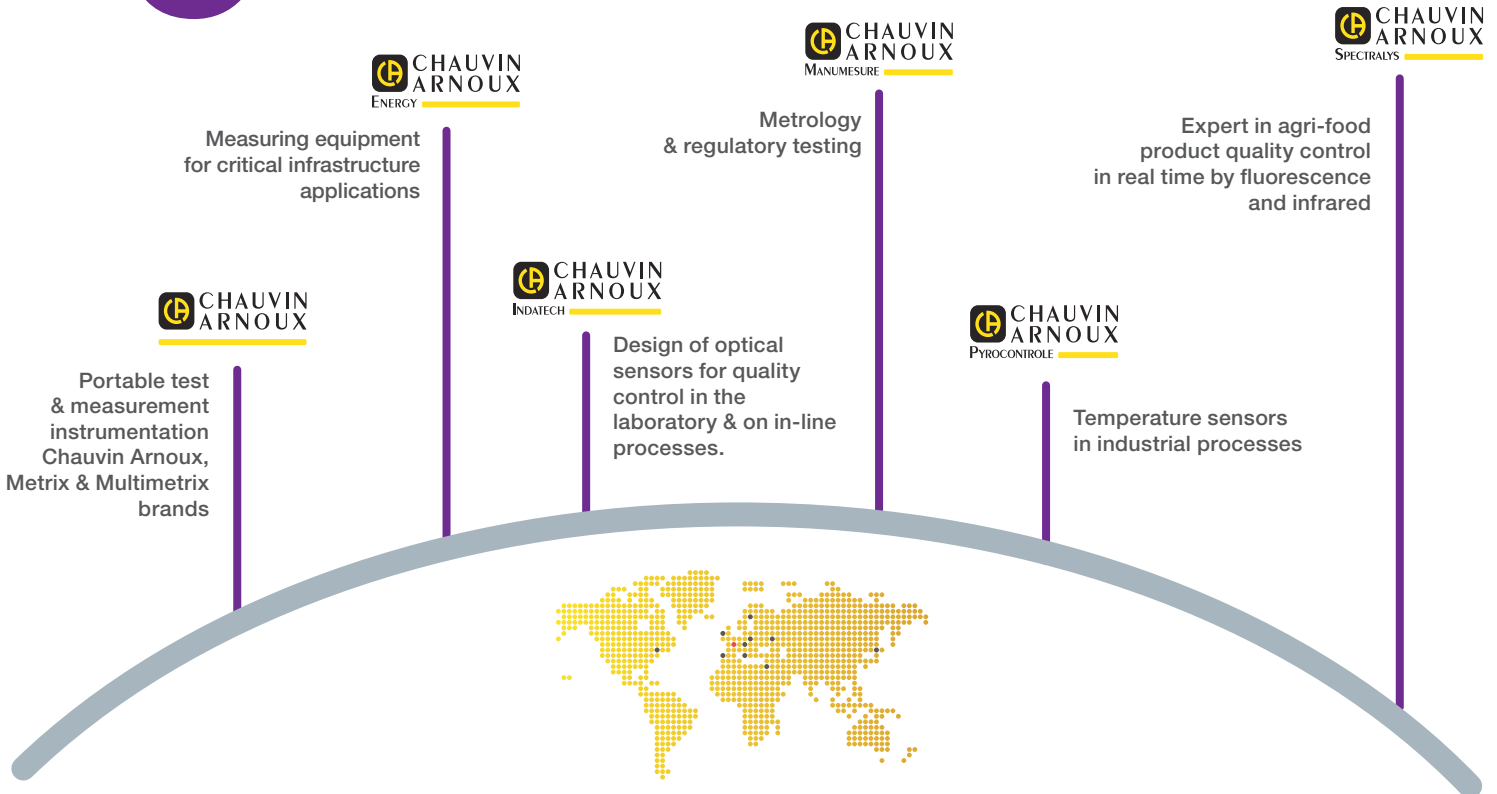

**100**  
millions d'euros  
in sales revenues

**1000**  
staff

**11%** of revenues  
invested in R&D

**10** subsidiaries  
spread across the world

**8** R&D departments  
worldwide

**8** production  
sites

Founded in 1893 by **Raphaël Chauvin** and **René Arnoux**, CHAUVIN ARNOUX is an expert in measurement of electrical and physical quantities in the industrial and tertiary sectors. Total control of product design and manufacturing in-house enables the Group to propose its customers a very broad product and service offering which meets all their needs.

The Group's quality policy ensures that the products delivered comply with its commitments and with both the national and international standards in terms of metrology, the environment and user safety.

# Chauvin Arnoux Energy

Chauvin Arnoux Energy, a company in the Chauvin Arnoux Group, is specialized in fixed equipment for measuring and supervising electrical networks to meet the needs of cutting-edge industries for intensive use in severe environments



**ELECTRICAL  
POWER  
GENERATION**



**ELECTRICAL POWER  
TRANSMISSION  
AND DISTRIBUTION**



**RAIL**



**NAVAL**



**INDUSTRY AND TERTIARY  
BUILDINGS**

## A FRENCH BRAND WITH INTEGRATED PRODUCTION

Chauvin Arnoux Energy, a French company in the Chauvin Arnoux Group, handles all aspects of product manufacturing; from design through to final testing of the equipment. Our teams guarantee the quality and reliability of all the instruments we supply, as well as support lasting decades.

## A LONG-TERM OFFERING

Our thorough mastery of our industrial know-how in our factories in France and our ability to keep abreast of the changes in the markets (materials used in our equipment) enable us to guarantee constant quality and long-term availability for our products.

METERS AND  
POWER MONITORS

NETWORK MONITORING  
FROM LV TO HV

CURRENT TRANSFORMERS  
AND SHUNTS

TRANSDUCERS

PANEL METERS AND  
SYNCHROCOUPLER

AUXILIARY RELAYS

MARINE CIVILE ET MILITAIRE

SERVICES AND TRAINING

# Our production sites and innovation center

---

For Chauvin Arnoux, manufacturing in France is a matter of course. Our manufacturing “made in France” guarantees quality and traceability. Our mastery of the production chain enables us to monitor products and solutions bearing the Chauvin Arnoux brand.

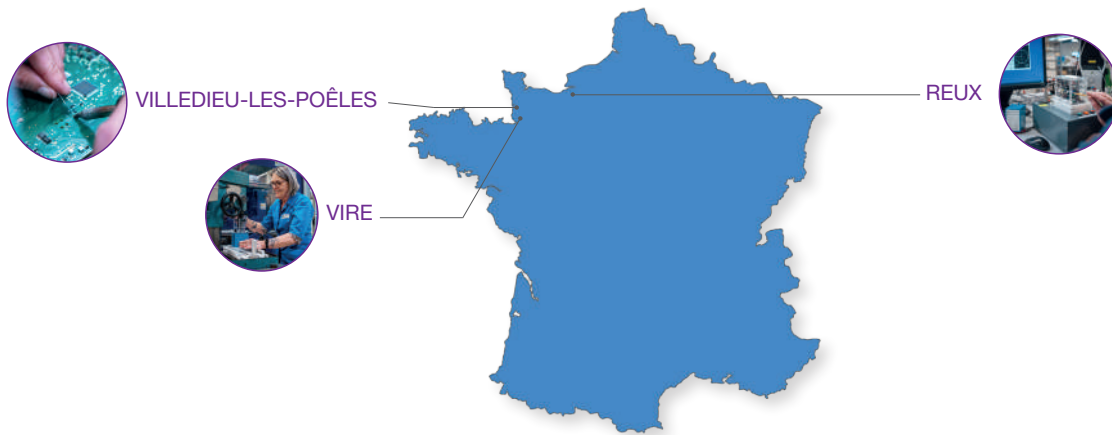

## VILLEDIEU-LES-POÊLES

---

More than a hundred people spread over an area of 4000 square meters dedicated mainly to manufacturing electronic items.

Here we make flexible or rigid single-sided and double-sided printed circuit boards up to Class V. 800,000 components can thus be assembled every week for CA Energy and the Group's other brands.

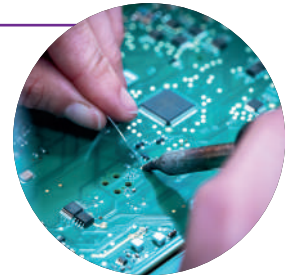

## VIRE

---

Vire is the site where our current sensors are assembled. In two main buildings covering 4,300 and 1,400 square meters, respectively, 140 people produce our spare parts.

The first building produces the bar-turned, machined and milled mechanical parts for our measuring instruments and the screening or casings made of sheet metal. The second is dedicated to plastic injection for molding our products' casings.



## REUX

---

10,000 square meters of buildings housing the Group's logistics, the spare parts warehouses, the assembly workshops, the finished products and the shipment department.

More than 60,000 references are managed in these warehouses, which group the parts needed to manufacture the measuring instruments assembled on the site and the finished products ready for shipment all over the world. The site is equipped with a single platform from which all the instruments from the Group's brands are shipped to France, our subsidiaries and the international markets.





The Nuclear sector has trusted us for more than 40 years

We offer a complete range of essential solutions for monitoring and controlling electrical distribution in nuclear power plants, designed to fulfil the strict requirements of this strategic sector.

#### PRODUCT QUALITY

We master the design of products specifically adapted to harsh nuclear environments.

Our solutions are developed to meet the most demanding technical requirements: longevity, reliability in the face of aging, and robust resistance to seismic stresses.

We provide support at every stage of technical qualification, in particular for compliance with the K3 standards.

#### QUALITY PROCESS

Our projects integrate nuclear qualification standards (RCCE, IEEE, etc.), guaranteeing consistent quality.

We draw up complete qualification files, ensuring a high level of industrial traceability and control, and meticulously manage the technical status of our products, as well as supporting our customers during audits..

#### LONG-TERM VISION

We support the extended life of nuclear power plants. Since the 1970s, our solutions have equipped the first generations of power plants, and continue to be modernized to meet today's standards.

Our products are updated for new projects and ten-yearly inspections, as well as to reinforce the safety of existing sites.

#### WORLDWIDE PRESENCE

Our solutions are installed in nuclear power plants all over the world.

They meet the specific requirements of different reactor models and generations (American, Russian, French, etc.), and are also implemented in new projects, notably in China and the UK.

METERS AND  
POWER MONITORS

NETWORK MONITORING  
FROM LV TO HV

CURRENT TRANSFORMERS  
AND SHUNTS

TRANSDUCERS

PANEL METERS AND  
SYNCHROCOUPLER

AUXILIARY RELAYS

MARINE CIVILE ET MILITAIRE

SERVICES AND TRAINING

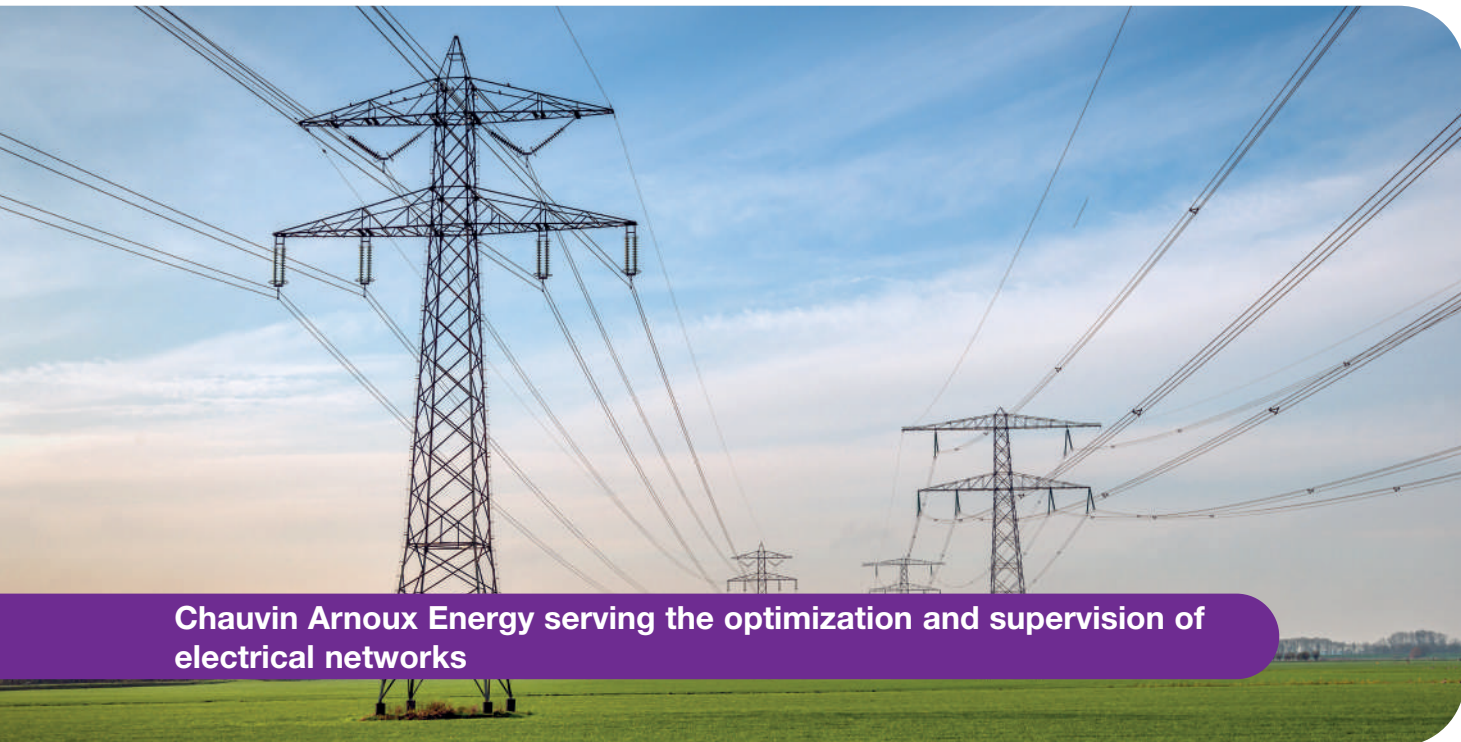

## Chauvin Arnoux Energy serving the optimization and supervision of electrical networks

Chauvin Arnoux Energy offers a complete range of innovative solutions to ensure the performance, reliability and safety of electrical networks. We actively support operators in their energy transition by optimizing the networks and facilitating contractualization between actors.

### RUGGED, HIGH-PRECISION PRODUCTS FOR CRITICAL ENVIRONMENTS

Our solutions are designed to excel in the harshest environments.

By complying with the strictest metrological standards (MID, IEC 60688) and signal analysis requirements (IEC 61000-4-30), we guarantee the accuracy, reliability and longevity of our products which are essential for electrical transformer stations.



### CONSTANT INNOVATION TO ANTICIPATE THE NETWORKS' NEEDS

With a significant proportion of our sales revenues devoted to research and development, we offer cutting-edge solutions which evolve according to the challenges facing the sector.

In close collaboration with energy sector professionals, we develop demonstrators to validate and refine our technical solutions before their roll-out.

### A COMPREHENSIVE RANGE ADAPTABLE TO TECHNOLOGICAL CHANGES

For decades, we have been supporting network managers with a wide range of metering, measurement and network analysis solutions.

Our products can adapt to the specific features and communication protocols on each installation, guaranteeing a smooth transition between different generations of technology.



## Chauvin Arnoux Energy and its solutions for the rail sector

The automation and reliability of rail systems are key issues for this sector. Thanks to our expertise, we contribute rugged solutions supporting this dynamic of intensifying passenger flows and strengthening security of the fixed equipment and rolling stock.

### OUR CONTRIBUTIONS TO RAIL NETWORKS AND METRO LINES

Since the late 1990s, we have played a key role in equipping several metro lines in Paris, marking a turning point in the modernization of urban transport and passenger safety. Since 1985, our relays have been integrated into TGV high-speed train systems, in particular for brake, door and speed control.

Our collaboration with major international manufacturers has resulted in the installation of our solutions on trains operating in countries such as South Korea, China, Mexico, Morocco, Italy and Saudi Arabia.

We are also active in fixed infrastructure for the rail network, with solutions adapted to mainline trains (signaling, level crossings, electrical substations) and urban transport (automated sliding doors, smoke evacuation, etc.).

### CERTIFICATIONS AND SAFETY: OUR QUALITY STANDARDS

Our R&D teams designs exceptionally resistant relays suited to the constraints in the rail sector, such as fire risks, shocks and vibrations.

We are proud to comply with SNCF specification NF F 62002-2, as well as the international standards applicable to rolling stock, such as EN 60077, EN 50155, EN 61373 and EN 45545- 2, certifying the reliability and quality of our products.

Our forced-guided relays, for example, are specially designed to ensure load switching safety in the critical rolling stock systems and comply with the EN 61810-3 standard.

We manufacture our relays in our own production plants in France and Italy. Thanks to our integrated production, we guarantee a long life span and traceability: we produce most of the parts, assemble them and carry out the final inspection.

### OUR PRODUCT OFFERING: SOLUTIONS SUITED TO EACH REQUIREMENT

We propose a wide range of products specially designed to meet the needs of the rail sector.. Our relays for fixed installations, such as those in the RGM, RDM, RCM or OK ranges, are used in the electrical substations. For rolling stock, our forced-guided relays and the POK and OK ranges offer proven solutions guaranteeing high security.

We also offer electrical measuring solutions with products like Enerium, Triad, and MAP, which allow optimized energy management on rail networks.

METERS AND POWER MONITORS

NETWORK MONITORING FROM LV TO HV

CURRENT TRANSFORMERS AND SHUNTS

TRANSDUCERS

PANEL METERS AND SYNCHROCOUPLER

AUXILIARY RELAYS

MARINE CIVILE ET MILITAIRE

SERVICES AND TRAINING



## Tailored Solutions for Military and Civilian Naval Applications

Chauvin Arnoux Energy proposes a comprehensive range of meteorological and electrical monitoring solutions which are essential for the propulsion and navigation systems of naval ships and submarines. We meet the specific requirements of industrial defense companies and administrations in France and worldwide.

### COMPLETE CUSTOMIZED SYSTEMS

We design high-precision sensors (wind vanes, anemometers, hygrometers) and temperature measurement and meteorological and electrical monitoring systems.

Our team of specialized engineers and technicians develops tailored solutions including digital meteorological chains and wind chains for accurate transmission of the weather data. Our modifiable multi-purpose repeaters can be used to collect and transmit all the information via Ethernet and digital links.

### A DEDICATED TEAM OF EXPERTS

Our engineers accompany you from design to installation, to guarantee perfectly adapted solutions. Based on detailed specifications, we provide advice, commissioning, equipment configuration and team training.

We offer turnkey projects that meet the most stringent technical requirements.

### 30 YEARS OF EXPERIENCE AND INTERNATIONAL TRUST

Chauvin Arnoux Energy has been equipping the French Navy and major French ports such as Marseille, Dunkerque and Le Havre for 30 years.

Internationally, we are trusted by the Navies of Chile, India, Malaysia, Brazil and many other countries.



## Buildings and Industry: we transform your energy challenges into measuring solutions

At Chauvin Arnoux Energy, we draw on our expertise to design high-performance products for varied environments: industrial sites (primary industries, manufacturing industries, heavy industry, etc.), and buildings (tertiary buildings, commercial buildings, data centers, residential buildings, etc.).

Our rugged, innovative solutions offer our customers complete control over their energy consumption, meeting the challenges of the energy efficiency regulations and current economic pressures. We also optimize the management and maintenance of internal electrical networks, with particular attention to sensitive processes.

### A COMPREHENSIVE OFFERING FOR METERING, MEASURING AND ANALYZING ELECTRICAL NETWORKS

We propose an extensive range of solutions suitable for all applications and covering the whole electrical system, from the point of delivery to the low-voltage sub-switchboards.

Thanks to our technical know-how, we meet varied needs from simple metering of energy consumption to thorough analysis of the waveforms and energy quality events.

### 25 YEARS OF EXPERTISE IN METERING PLANS AND MEASUREMENT

To guarantee our solutions' reliability and effectiveness, we accompany our customers at every step:

- Customized advice: selection of the equipment according to the requirements and constraints.
- Support for implementation: parameterization and integration.
- Interoperability: compatibility with the meter-reading and data collection systems on the market.

### UNIQUE, FORWARD-LOOKING KNOW-HOW

Our Altys electricity meter is the market leader and the reference for medium-voltage customer delivery points on the French grid.

This know-how lies at the heart of our innovations for electricity meters intended for buildings and industry.

All our products fulfil the requirements of the MID standard, guaranteeing reliable solutions certified for energy rebilling.

### INNOVATION AT THE HEART OF OUR PRODUCTS

Every day, we push back the limits of compact design, connectivity and simple use. Our latest product, the Ulys MCM, is revolutionizing electrical measurement by centralizing the consumption and measurements from an entire site in a single box positioned upstream.

At Chauvin Arnoux Energy, we turn your energy challenges into measurement solutions.

METERS AND POWER MONITORS

NETWORK MONITORING FROM LV TO HV

CURRENT TRANSFORMERS AND SHUNTS

TRANSDUCERS

PANEL METERS AND SYNCHROCOUPLER

AUXILIARY RELAYS

MARINE CIVILE ET MILITAIRE

SERVICES AND TRAINING



**ENERGY METERING PLAN**

# **METERS** **AND POWER MONITORS**



- 14 OVERVIEW OF THE RANGE
- 18 SELECTION GUIDE
- 28 SUBMETERS
- 48 MULTICHANNEL METERS
- 58 TARIFF METERS
- 62 POWER MONITORS

METERS AND  
POWER MONITORS

NETWORK MONITORING  
FROM LV TO HV

CURRENT TRANSFORMERS  
AND SHUNTS

TRANSDUCERS

PANEL METERS AND  
SYNCHROCOUPLER

AUXILIARY RELAYS

CIVILIAN AND MILITARY NAVAL  
APPLICATIONS

SERVICES AND TRAINING

# METERS AND POWER MONITORS

## MEMO RANGE OF SUBMETERS FOR SIMPLE METERING FUNCTIONS

### SINGLE-PHASE NETWORKS



**MEMO MD32**  
32 A direct input  
Class 1  
Energy meter for single-phase networks with direct connection up to 32 A.  
[page 28](#)



**MEMO MD65**  
65 A direct input  
Class 1  
Energy meter for single-phase networks with direct connection up to 65 A.  
[page 30](#)



**MEMO TD80**  
80 A direct input  
Class 1  
Energy meter for single-phase networks with direct connection up to 80 A.  
[page 32](#)

### THREE-PHASE NETWORKS

## ULYS RANGE OF SUBMETERS FOR ADVANCED METERING FUNCTIONS

### SINGLE-PHASE NETWORKS



**ULYS MD45-M**  
45 A direct input  
MID Class B  
Built-in communication  
Energy meter for single-phase networks with direct connection up to 45 A.  
[page 34](#)



**ULYS MD100-M**  
100 A direct input  
MID Class B  
Built-in communication  
Energy meter for single-phase networks with direct connection up to 100 A.  
[page 36](#)



**ULYS MD45-M EV**  
45 A direct input  
MID Class B Built-in communication  
Energy meter for single-phase networks, direct connection up to 45 A, for electric vehicle applications  
[page 54](#)

### THREE-PHASE NETWORKS



**ULYS TDA80-M**  
80 A direct input  
MID Class B  
Communication with ULYSCOM modules  
Energy meter for three-phase networks with direct connection up to 80 A.  
[page 38](#)



**ULYS TTA-M**  
Connection to CT  
MID Class B  
Communication with ULYSCOM modules  
Energy meter for three-phase networks with connection to CT.  
[page 40](#)



**ULYS TD80-M**  
80 A direct input  
MID Class B  
Built-in communication  
Energy meter for three-phase networks with direct connection up to 80 A.  
[page 42](#)



**ULYS TT-M**  
Connection to CT  
MID Class B  
Built-in communication  
Energy meter for three-phase networks, connection to CT.  
[page 44](#)



**ULYS FLEX**  
On Rogowski coils  
Measurement from 0.3 A to 20,000 A Built-in RS485 communication.  
[page 46](#)



**ULYS TD100-M EV**  
Connection to CT  
MID Class B  
Energy meter for three-phase networks, connection to CT, for electric vehicle applications  
[page 56](#)

## USER SECTORS



Tertiary



Industry



Energy generation



Energy transmission & distribution



Energy efficiency

## METERING SOLUTION



### ULYS MCM

Connection to CT or Rogowski coil  
Power monitor and multichannel energy meter  
Up to 18 three-phase channels  
[page 48](#)

## TARIFF METER



### ALTYS

Class 0.5s - MID  
Connected to the MV network.  
Takes into account all the tariff offers on the market.  
[page 58](#)

## POWER MONITORS

### 96 X 96 MM FORMAT



### MEMO P200

Class 0.5  
Electrical energy.  
[page 62](#)



### ENERUM 50

Class 0.5  
Electrical energy.  
[page 64](#)



### ENERUM 150

Class 0.5  
Electrical energy.  
[page 64](#)

### 144 X 144 MM FORMAT



### ENERUM 100

Class 0.5  
Multi-energy.  
[page 64](#)



### ENERUM 110

Class 0.5/0.2  
Without display  
Multi-energy.  
[page 64](#)



### ENERUM 200

Class 0.5/0.2  
Multi-energy.  
[page 64](#)



### ENERUM 210

Class 0.5  
Without display  
Multi-energy.  
[page 64](#)



### ENERUM 300

Class 0.2  
Qualimetry.  
[page 64](#)



### ENERUM 310

Class 0.2  
Without display  
Qualimetry.  
[page 64](#)

## ASSOCIATED SOFTWARE

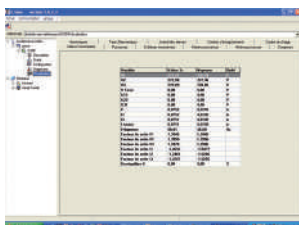

### E.VIEW

Configuration and diagnostic software  
Reading of the digital inputs and/or forcing of the digital and analog outputs.  
[page 74](#)

METERS AND POWER MONITORS

NETWORK MONITORING FROM LV TO HV

CURRENT TRANSFORMERS AND SHUNTS

TRANSDUCCERS

PANEL METERS AND SYNCHROCOUPLER

AUXILIARY RELAYS

CIVILIAN AND MILITARY NAVAL APPLICATIONS

SERVICES AND TRAINING

# QUICK SELECTION GUIDE

## FOR SUBMETERS

### MEMO range

#### FOR SIMPLE METERING FUNCTIONS



#### Optimized inventory

A limited number of references corresponding to the most widely-used electrical feeders.



#### Clear, simple display

Direct access to your consumption data.



#### No parameter settings

Operational as soon as it is powered up

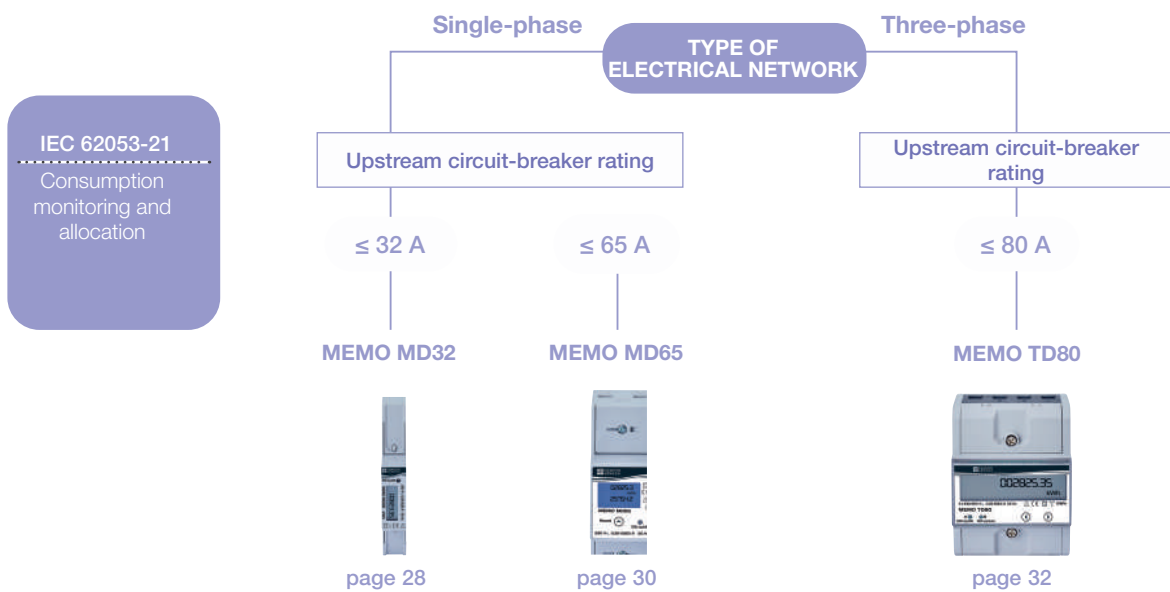

	IEC	IEC	IEC
<b>NON-COMMUNICATING</b>	MEMO MD32 P01330740	MEMO MD65 P01330741	MEMO TD80 P01330745
<b>RS 485 Modbus</b>	-	-	-
<b>Ethernet Modbus/TCP</b>	-	-	-

## USER SECTORS



Tertiary



Industry



Energy efficiency

## ULYS range

### FOR ADVANCED METERING AND MEASUREMENT FUNCTIONS



#### Interoperability

Built-in communication (Modbus, M-bus, Ethernet) and pulse outputs in a highly compact casing.



#### Fair rebilling

MID, double tariff, partial metering.



#### Customizable multiple measurements

Assignable display. Local or remote access via web pages or FTP push.



#### Simple implementation

Large choice of sensors for current measurement.

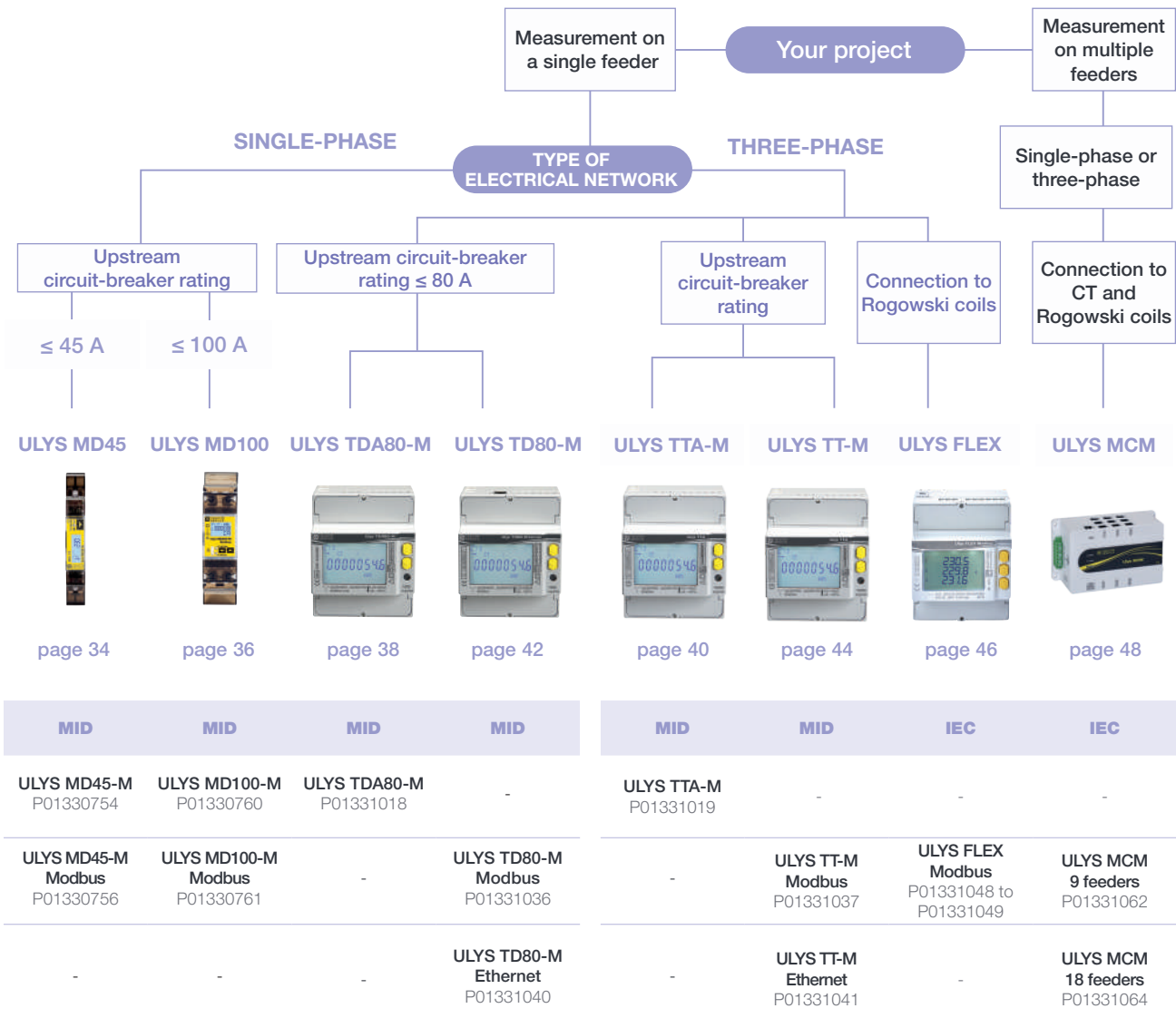

METERS AND POWER MONITORS

NETWORK MONITORING FROM LV TO HV

CURRENT TRANSFORMERS AND SHUNTS

TRANSDUCERS

PANEL METERS AND SYNCHROCOUPLER

AUXILIARY RELAYS

CIVILIAN AND MILITARY NAVAL APPLICATIONS

SERVICES AND TRAINING

# METER SELECTION GUIDE

## BY FUNCTIONS

### MEMO range

		Single-phase		Three-phase	
		MEMO MD32	MEMO MD65	MEMO TD80	
		page 28	page 30	page 32	
model					
	Rating	100	100	100	
	Calibre	32 A	65 A	80 A	
	 MID certification	no	no	no	
	Accuracy class	IEC Class 1	IEC Class 1	IEC Class 1	
<b>Installation</b>	Format	DIN modules	1	2	4
	Auxiliary power supply	Self-powered	Self-powered		
	Rated voltage		230 Vac	230 Vac	230/400 Vac
	Inputs	Direct/Sensors	32 A	65 A	80 A
<b>Energy metering and management</b>	Display and communication (if relevant)	total kWh	total and partial kWh	total and partial kWh	
<b>Multimeasurement</b>	Display and communication (if it exists)	-	-	-	
<b>Recording / Push FTP</b>		-	-	-	
<b>Inputs / Outputs</b>	Pulse output(s)	1	1	1	
	Tariff change input	-	-	-	
<b>Communication</b>	RS485 Modbus	-	-	-	
	Ethernet Modbus	-	-	-	

## USER SECTORS



Tertiary



Industry



Energy efficiency

## ULYS range

Single-phase		Three-phase			Multiple feeders
ULYS MD45-M	ULYS MD100-M	ULYS TDA80-M ULYS TD80-M	ULYS TTA-M ULYS TT-M	ULYS Flex Modbus	ULYS MCM
page 34	page 36	page 38 page 42	page 40 page 44	page 46	page 48
					
210	210	210	210	210	210
45 A	100 A	80 A	On CT 1/5 A	0,3 to 20000 A	Jusqu' to 3000A
yes	yes	yes	yes	no	no
MID Class B				IEC Class 1	IEC Class 0.5
1	2	4	4	4	8 (156x90x61)
Self-powered				85-265 Vac	100-240 Vac
230 Vac	230 Vac	230/400 Vac	230/400 Vac	10/17 to 285/495 Vac	25 to 400 Vac (P-P)
Direct 45 A	Direct 100 A	Direct 80 A	Isolated 1/5 A	On Rogowski coils	x9 or x18 feeders on CT or on Rogowski coils
Bidirectional ,kWh, total kVAh and partial kWh	Bidirectional ,kWh, total kVAh and partial kWh	Bidirectional, kWh, kVAh, total, partial and per-phase kVAh	Bidirectional, kWh, kVAh, total, partial and per-phase kVAh	Bidirectional, kWh, kVAh, total and per-phase kVAh	kWhh, kVAh, kVAh per feeder
V, I, P, Q, S, F, PF	V, I, P, Q, S, F, PF	V, U, I, P, Q, S, F, PF, $\sum P, \sum Q, \sum S$	V, U, I, P, Q, S, F, PF, $\sum P, \sum Q, \sum S$	V, U, I, P, Q, S, F, PF, $\sum P, \sum Q, \sum S$	V, U, F, I, P, Q, S, PF, $\sum P, \sum Q, \sum S$ per feeder
-	-	Recording and Push FTP on Ethernet version		-	-
1	2	2 on TDA80-M - 1 on TD80-M	2 on TTA-M - 1 on TT-M	1 (alarm or pulse)	1
ULYS MD45-M	ULYS MD100-M	1 (except Ethernet model)	1 (except Ethernet model)	no	no
ULYS MD45-M Modbus	ULYS MD100-M Modbus	ULYS TD80-M Modbus	ULYS TT-M Modbus	ULYS-FLEX Modbus	On all models
-	-	ULYS TD80-M Ethernet	ULYS TT-M Ethernet	-	

METERS AND POWER MONITORS

NETWORK MONITORING FROM LV TO HV

CURRENT TRANSFORMERS AND SHUNTS

TRANSDUCERS

PANEL METERS AND SYNCHROCOUPLER

AUXILIARY RELAYS

CIVILIAN AND MILITARY NAVAL APPLICATIONS

SERVICES AND TRAINING

# QUICK SELECTION GUIDE

## FOR POWER MONITORS

### MEMO range

- All-in-one screen, particularly easy to read
- Simple to implement and operate
- Controlled inventory covering your main needs

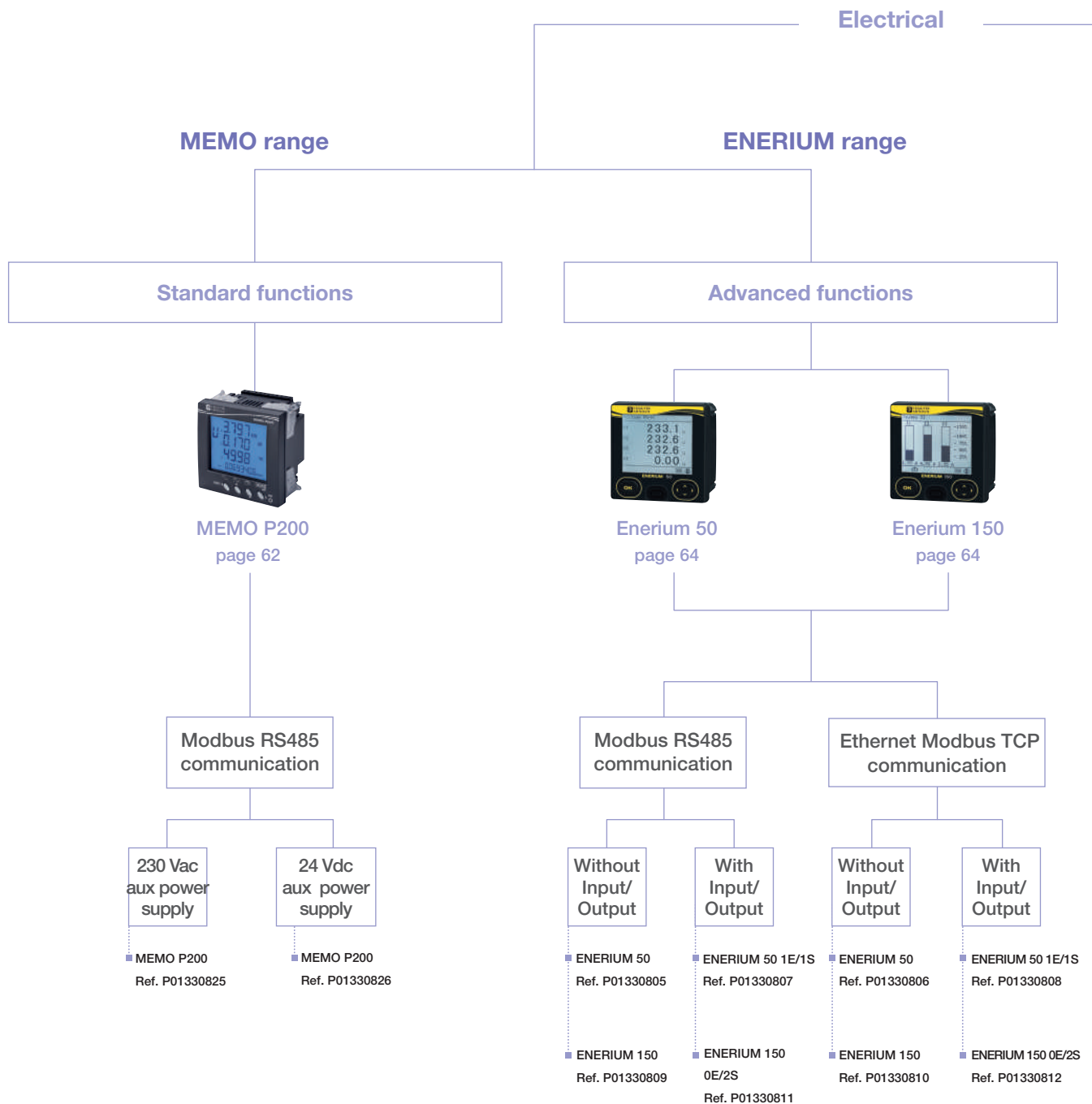

## USER SECTORS



Industry



Energy generation



Energy transmission & distribution



Energy efficiency

## ENERIUM range

- Accuracy suitable for the most critical MV/LV measurements
- The history and diagnostic tools to understand everything about your electrical feeder
- Unique on the market: up to 8 totally integrated inputs/outputs (on-off or analog)
- Energy quality measurement at the heart of a power monitor

### Application

### Multi-energy

## ENERIUM range

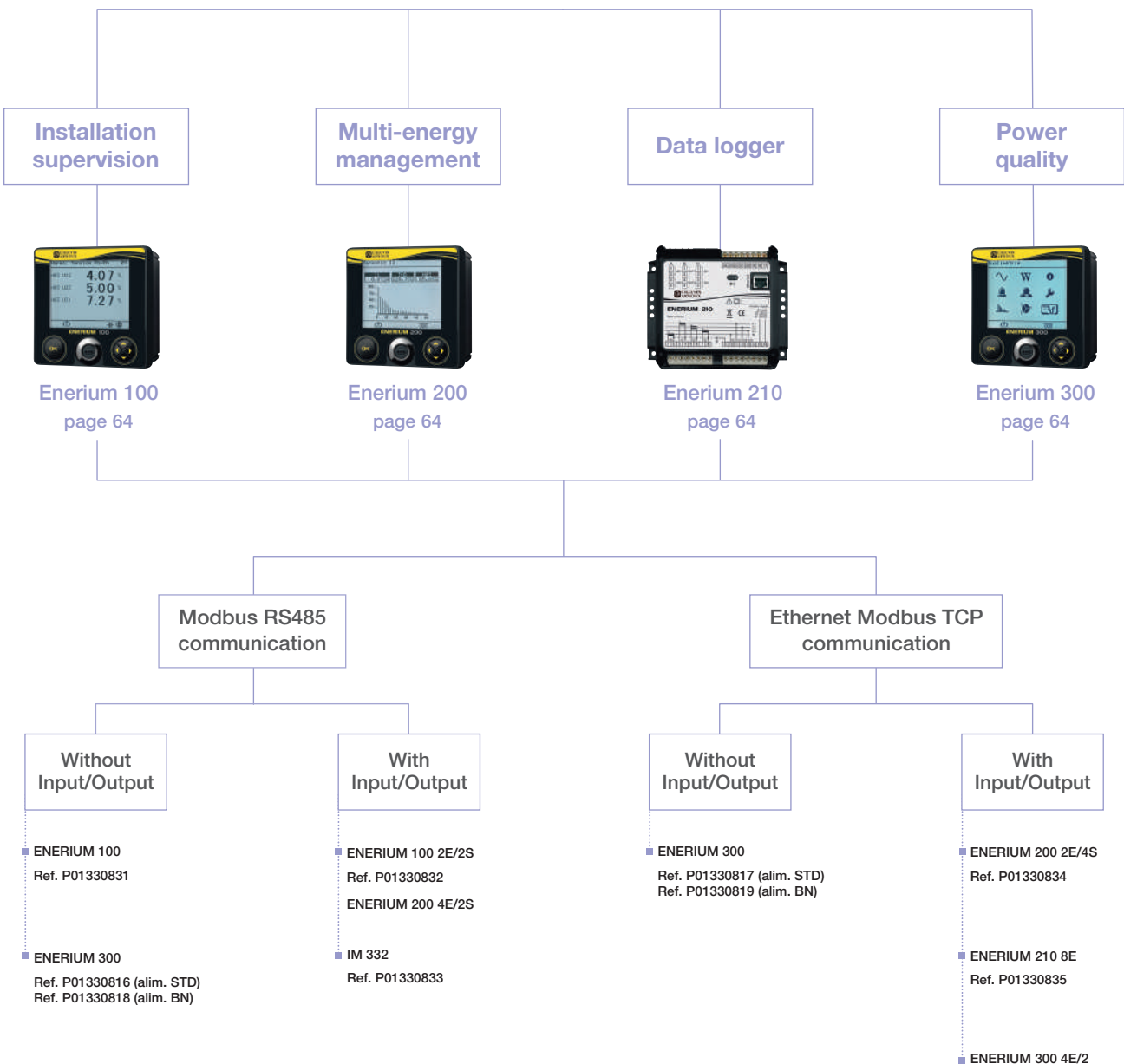

METERS AND POWER MONITORS  
NETWORK MONITORING FROM LV TO HV  
CURRENT TRANSFORMERS AND SHUNTS  
TRANSDUCERS  
PANEL METERS AND SYNCHROCOUPLER  
AUXILIARY RELAYS  
CIVILIAN AND MILITARY NAVAL APPLICATIONS  
SERVICES AND TRAINING

# CHOOSING YOUR POWER MONITOR

## MEMO

page 62



## ENERIUM

page 64



	MEMO P200	Enerium 50	
<b>Electrical energy management</b>	Accuracy	0.5 %	
	Measurement of V, U, I Inst. Min/Max Avg.	■	
	Measurement of P, Q, S Inst. Min/Max Avg.	■	
	Energy generated and consumed	■	
	Consumption curves (10-min. average values)		8
<b>Multi-energy management</b>	Inputs for pulses from other meters (water, gas, etc.)		0, 1 or 2
	Inputs for analog quantities (temp., flow rate, pressure, insolation, etc.)		
<b>Installation monitoring</b>	Trend curves		
	Management of alarms on thresholds		16
	Alarms log (recordings)		64
	Graph (Fresnel)		
	Pulse or alarm outputs	1 (pulse)	0, 1 or 2
	Analog outputs		0 or 2
<b>Power quality</b>	THD / PF / Tan $\phi$	■	■
	Harmonics by orders with graphical representation		25
	Waveform capture (U, V, I, In)		
	EN50160 analysis		
Max. no. of input + output options	1	2	
RS485 - Modbus	■	■	
Ethernet - Modbus TCP		■	
Format (mm)	96 x 96	96 x 96	
Available in version without display			

## USER SECTORS



Industry



Energy generation



Energy transmission & distribution



Energy efficiency

## ENERIUM

page 64



page 64



page 64



page 64



Enerium 150	Enerium 100	Enerium 200	Enerium 300
0.5 %	0.5 %	0.2 %	0.2 %
■	■	■	■
■	■	■	■
■	■	■	■
8		8	8
0, 1 or 2	0, 2, 4, 6 or 8	0, 2, 4, 6 or 8	0, 2, 4, 6 or 8
	0, 2, 4, 6 or 8	0, 2, 4, 6 or 8	0, 2, 4, 6 or 8
4	4	4	4
16	16	16	16
64	64	64	64
■	■	■	■
0, 1 or 2	0, 2, 4, 6 or 8	0, 2, 4, 6 or 8	0, 2, 4, 6 or 8
0 or 2	0, 2, or 4	0, 2, or 4	0, 2, or 4
■	■	■	■
50	25	50	50
			16
			■
2	8	8	8
■	■	■	■
■	■	■	■
96 x 96	144 x 144	144 x 144	144 x 144
	ENERIUM 110	ENERIUM 210	ENERIUM 310

METERS AND POWER MONITORS

NETWORK MONITORING FROM LV TO HV

CURRENT TRANSFORMERS AND SHUNTS

TRANSDUCERS

PANEL METERS AND SYNCHROCOUPLER

AUXILIARY RELAYS

CIVILIAN AND MILITARY NAVAL APPLICATIONS

SERVICES AND TRAINING

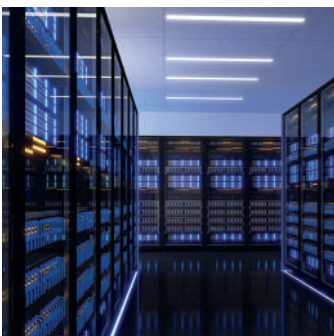

# MID DIRECTIVE

## WHAT IS THE MID?

The MID (Measuring Instruments Directive - 2004/22/CE) is a European Directive issued in 2004 which applies to devices and systems with a measuring function in order to protect the interests of consumers, particularly in the context of commercial transactions.

These measuring instruments may be active electrical energy meters (Annex MI003 of the Directive), water, gas or heat meters, weighing instruments, etc.

## Scope

The MID covers three types of usage: "Measurements of residential, commercial and light industrial use". A minimum meter accuracy class is imposed for each usage category as stipulated in the Directive 2004/22/CE:

- In residential use, "(...) any meter of at least Class A is sufficient (...) but a Class B meter is required in the following cases:
  - when the current  $I_{max}$  is greater than or equal to 45 A, in the case of a single-phase connection, or 15 A in the case of a three-phase connection;
  - when the meter records the consumption data corresponding to specific time slots in separate registers (...)"
- In commercial use or light industry "(...) a meter of at least Class B is required. A Class C meter may be required, however".

The MID does not however apply to "Energy meters on which the [Ph-Ph] voltage between the connection terminals exceeds 600 V"

## Regulatory Context

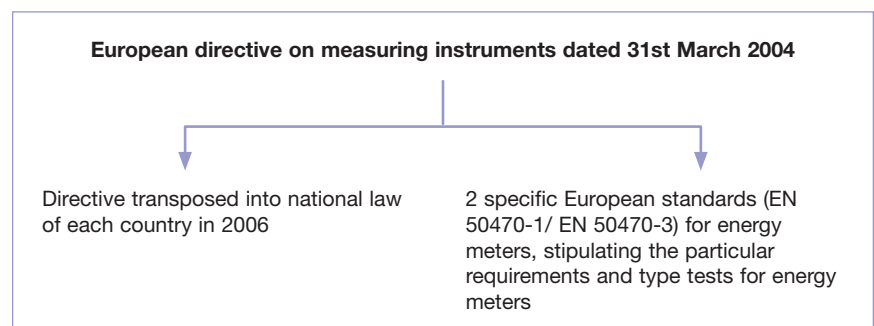

## Conditions of application

In the European Union, the use of MID-certified meters on “private”(1) electrical networks has been made mandatory in the context of active energy billing based on consumption readings by index differences.

Typical examples include: camping sites, holiday rentals, student accommodation, office buildings, shopping centres, marinas, exhibition halls, electric vehicle recharging stations, etc.

As the MID is applicable to all European Union Member States, certification of a meter by a Notified Body (NB) means that no other testing by a national legal metrological service is required. So a MID-certified Chauvin Arnoux Energy meter can be used as an active energy billing meter in all European Union countries.

The Directive also imposes product certification according to the EN50470-1/-3 standard, as well as design certification (Module B) and manufacturing process certification (Module D) by a Notified Body, in order to ensure product traceability and guarantee its metrological value, thus helping to protect consumers

<sup>1</sup> Downstream of the meter at the network manager’s point of supply.

## Chauvin Arnoux Energy products concerned

- The active energy meters whose references end in "M", such as the **ULYS MD45-M**, also identified with the MID logo in our catalog, fully comply with the MID.
- The directive does not apply, in particular, to current transformers, power monitors and the additional functions (other than active energy measurement) offered by smart meters.

## Accuracy Class and meter identification

The EN50470-1/-3 defines three specific accuracy Classes: A, B and C. These are comparable to the IEC62053-21/-22 active energy metering standards: Class A is equivalent to 2 % accuracy, Class B to 1 % and Class C to 0.5 %.

For total compatibility with the Directive, there must be regulatory marking for meter traceability. In addition to the manufacturer’s name and the product reference, this regulatory marking comprises:

- A reference to Module D certification

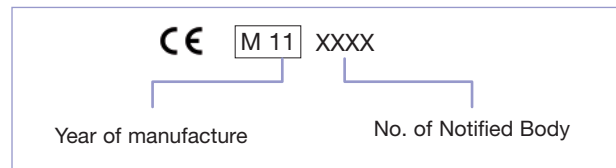

- A reference issued by the Notified Body certifying conformity with regard to the Module B design inspection
- The meter’s serial number

A declaration of conformity is enclosed with each product sold.

# PERMANENT MEASUREMENT SYSTEM

Know all the details: where, when, how, how much?  
supervising, managing and exchanging

## Metering and measurement

A full range of energy meters and power monitors that comply with the most demanding standards to ensure optimum accuracy.



METERS AND POWER MONITORS  
 NETWORK MONITORING FROM LV TO HV  
 CURRENT TRANSFORMERS AND SHUNTS  
 TRANSDUCERS  
 PANEL METERS AND SYNCHROCOUPLER  
 AUXILIARY RELAYS  
 CIVILIAN AND MILITARY NAVAL APPLICATIONS  
 SERVICES AND TRAINING

**METERING STATION**

MAP network analyzer



LVGS



ENERIUM 300 Power monitor



ENERIUM 50 Power monitor



ENERIUM 150 Power monitor



Secondary switchboard



MEMO P200 Power monitor



ULYS Submeter



MEMO 4 Submeter



Power supply control cabinet



ULYS Submeter

# MEMO MD32

## SINGLE-PHASE 32 A

Energy meters for single-phase networks.  
Direct connection up to 32 A.



### USER SECTORS



Tertiary



Economical solution



Sealable  
terminal covers



Pulse output as standard



### GENERAL SPECIFICATIONS

The **MEMO** range of meters is the economical solution for measuring electrical consumption on a 230 V single-phase network.

Equipped with a digital display, the **MEMO MD32** offers Class 1 accuracy, in total compliance with the IEC 62053-21 standard.

- Mounting on DIN rail with direct connection up to 32 A
- Sealable cover (phase and neutral terminals)
- Pulse output as standard

- 32 A rated current
- Class 1 as per IEC 62053-21
- Compact: only one DIN module
- Pulse output as standard
- Sealing system on the phase and neutral terminals

## ELECTRICAL SPECIFICATIONS

Current input	
Type	Single-phase
Rated current (I <sub>max</sub> )	(5) 32 A
Inrush current (I <sub>st</sub> )	20 mA
Voltage input	
Rated voltage (U <sub>n</sub> )	230 Vac (± 20%)
Consumption	≤ 8 VA - ≤ 0,4W
Rated frequency	50 / 60 Hz
Pulse output	
Duration	80 ms
Weight	1,000 pulses / kWh
Maximum voltage	12-27 Vdc
Maximum current	27 mA
Accuracy	
Active energy	Class 1 as per IEC 62053-21
Metrological LED	
Weight	1,000 pulses / kWh

## MECHANICAL SPECIFICATIONS

Ingress protection	IP 50 front panel
Power circuit connection	Screw terminal strip up to 12 mm <sup>2</sup> for flexible wires (10 mm <sup>2</sup> for rigid wires)
Pulse output connection	Screw terminal strip for 1.5 mm <sup>2</sup> wires
Sealing system	On the phase and neutral terminals
Mounting	On 35 mm DIN rail
Weight	80 g

## ENVIRONMENT

Operating temperature	-25 °C to +55 °C
Storage temperature	-25 °C to +70 °C
Relative humidity in operation	75 % max

## DISPLAY

Display	LCD 5 + 2 digits
Total (kWh)	Indication of total consumption

## TO ORDER

Model	Reference
MEMO MD32	P01330740

## DIMENSIONS (MM)

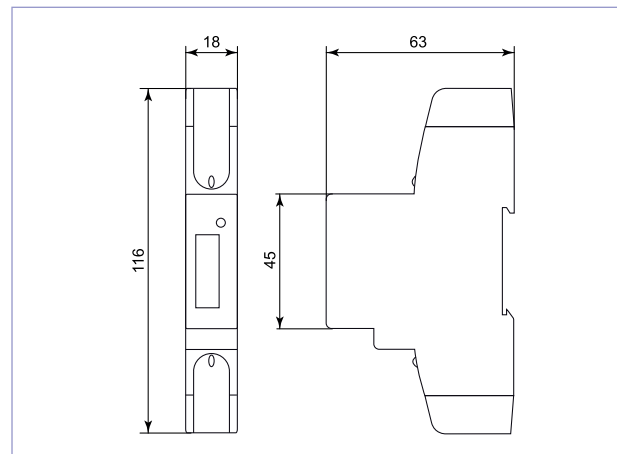

## ELECTRICAL CONNECTIONS

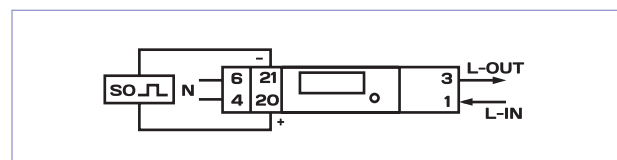

# MEMO MD65

## SINGLE-PHASE 65 A

Energy meter for single-phase networks.  
Direct connection up to 65 A.

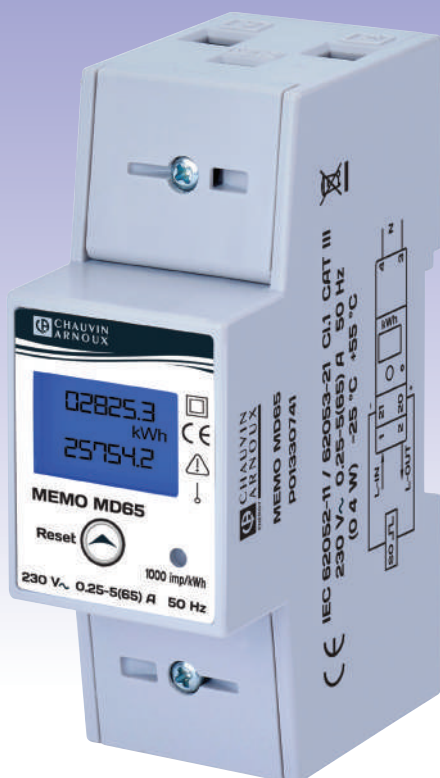

### USER SECTORS



Tertiary



Display of energy index on an LCD screen



Sealable terminal cover



Direct connection up to 65 A

### GENERAL SPECIFICATIONS

**MEMO MD65** is a single-phase active energy meter specially designed for low-voltage applications.

Equipped with a 2-line digital display, the MEMO MD65 offers simultaneous display of the cumulated and partial index.

- Active energy measurement on single-phase networks
- 1 pulse output which can be connected to a data logger
- Direct current inputs up to 65 A
- Display of the total and partial active energy



- Class 1 as per IEC 62053-21
- Compact: only 2 DIN modules
- Pulse output
- LCD screen

## ELECTRICAL SPECIFICATIONS

Current input	
Type	SINGLE-PHASE
Rated current (I <sub>max</sub> )	(5) 65 A
Inrush current (I <sub>st</sub> )	20 mA
Voltage input	
Rated voltage (U <sub>n</sub> )	230 V (±30 %)
Consumption	≤ 8 VA
Frequency	50/60 Hz
Pulse output	
Duration	90 ms
Weight	1000 pulses/kWh
Maximum voltage	12-27 Vdc
Maximum current	27 mA
Accuracy	
Active energy	Class 1 as per IEC 62053-21
Metrological LED	
Weight	1000 pulses / kWh

## MECHANICAL SPECIFICATIONS

Ingress protection	IP50
Power circuit connection	Screw terminal strip for 25 mm <sup>2</sup> wires
Pulse output connection	Screw terminal strip for 1.5 mm <sup>2</sup> wires
Mounting	On 35 mm DIN rail
Weight	160 g

## ENVIRONMENT

Operating temperature	-25 °C to +65 °C
Storage temperature	-25 °C to + 70°C
Relative humidity in operation	75% max

## DISPLAY

Display	LCD
Number of digits	Total/partial Ea: 6+1

## TO ORDER

Model	Reference
MEMO MD65	P01330741

## DIMENSIONS (MM)

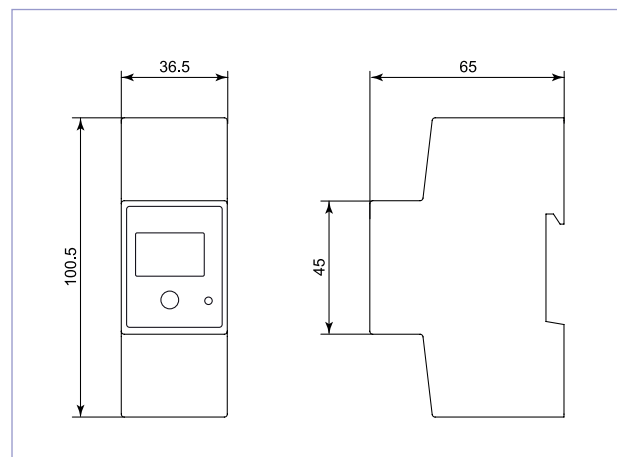

## ELECTRICAL CONNECTIONS

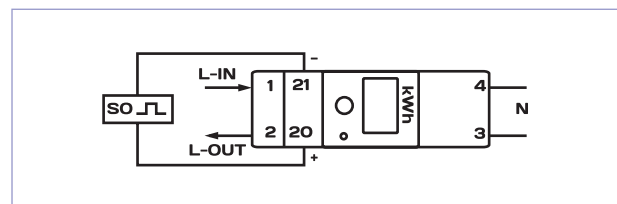

METERS AND  
POWER MONITORS

NETWORK MONITORING  
FROM LV TO HV

CURRENT TRANSFORMERS  
AND SHUNTS

TRANSDUCERS

PANEL METERS AND  
SYNCHROCOUPLER

AUXILIARY RELAYS

CIVILIAN AND MILITARY NAVAL  
APPLICATIONS

SERVICES AND TRAINING

# MEMO TD80

## THREE-PHASE 80 A

Energy meter for three-phase networks.  
Direct connection up to 80 A.



### USER SECTORS



Tertiary



Industry



Energy  
efficiency



Display of the energy  
index on LCD screen



Sealable  
terminal covers



Direct connection  
up to 80 A

### DESCRIPTION

**MEMO TD80** is an energy meter for use on three-phase networks.

- 1 pulse output as standard
- Direct current inputs up to 80 A
- Multi-measurement: cumulated and partial index
- Sealable terminal covers



- Class 1 as per IEC 62053-21
- 4 DIN modules
- Pulse output as standard

## ELECTRICAL SPECIFICATIONS

Current input	
Type	direct
Rated current (I <sub>max</sub> )	(5) 80 A
Inrush current (I <sub>st</sub> )	20 mA
Voltage input	
Rated voltage (U <sub>n</sub> )	3 x 230/400 Vac (±20%)
Consumption	≤ 8 VA - ≤ 0.4 W
Frequency	50/60 Hz
Pulse output	
Duration	30 ms
Weight	100 pulses/kWh
Maximum voltage	12-27 Vdc
Maximum current	27 mA
Accuracy	
Active energy	Class 1 as per IEC 62053-21
Metrological LED	
Weight	1000 pulses / kWh 1000 pulses / kVAh

## MECHANICAL SPECIFICATIONS

Format	4 DIN modules
Mounting	On 35 mm DIN rail
Power circuit connection	Screw terminal strip for 35 mm <sup>2</sup> wires
Pulse output connection	Screw terminal strip for 1.5 mm <sup>2</sup> wires
Ingress protection	IP50 front panel

## ENVIRONMENT

Operating temperature	- 25 °C to +65 °C
Storage temperature	- 25 °C to +75 °C
Relative humidity	Max. 85 % without condensation

## DISPLAY

Display	LCD
Number of digits	6+2

## TO ORDER

Model	Reference
MEMO MD65	P01330745

## DIMENSIONS (MM)

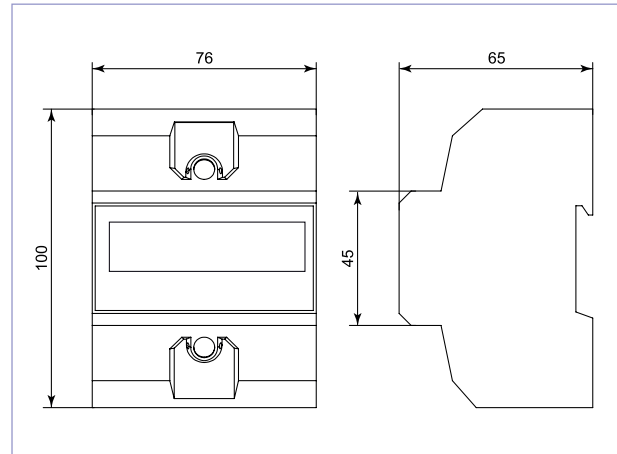

## ELECTRICAL CONNECTIONS

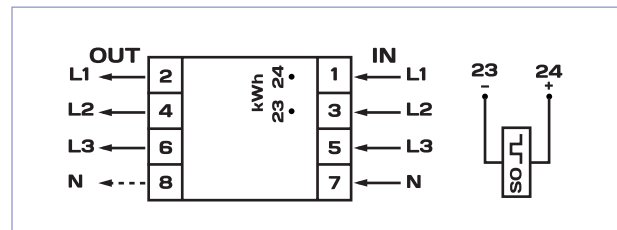

METERS AND  
POWER MONITORS

NETWORK MONITORING  
FROM LV TO HV

CURRENT TRANSFORMERS  
AND SHUNTS

TRANSDUCERS

PANEL METERS AND  
SYNCHROCOUPLER

AUXILIARY RELAYS

CIVILIAN AND MILITARY NAVAL  
APPLICATIONS

SERVICES AND TRAINING

# ULYS MD45

## SINGLE-PHASE 45 A

Energy meters for single-phase networks.  
Direct connection up to 45 A.



### USER SECTORS



Tertiary



Industry



Energy  
efficiency



Quick parameter modification  
using touch-sensitive button on  
front panel or optical head



Sealable terminal covers  
delivered as standard



Backlit LCD screen

### GENERAL SPECIFICATIONS

- Display and parameters programmable using the touch-sensitive key on the front panel
- Power-off meter
- Tariff-change input on ULYS MD45-M
- 1 pulse output as standard (weight assignable)
- MID version for energy rebilling on private networks
- Multi-measurement:
  - Instantaneous quantities: V, I, P, Q, S, PF and F
  - Instantaneous quantities and energy indices according to energy direction and tariff
- RS485 Modbus communication (ULYS MD45-M Modbus)
- Bidirectionality of the energy (consumed and generated)
- Reinitializable partial active energy index

When used with a remote meter-reading solution and energy management software, you can recover your energy consumption data remotely on your PC so that you can automatically generate consumption reports and allocate the consumption fairly.



- Built-in RS485 Modbus communication
- Reinitializable partial meter index
- Bidirectional metering
- Double-tariff metering
- Totally assignable on front panel or via optical head
- Customizable multi-measurement display
- MID Class B

## ELECTRICAL SPECIFICATIONS

<b>Current input</b>	
Rated current (I <sub>max</sub> )	45 A
Minimum current (I <sub>min</sub> )	250 mA
Inrush current (I <sub>st</sub> )	20 mA
<b>Voltage input</b>	
Rated voltage (U <sub>n</sub> )	230 Vac (-15% / +10%)
Consumption	≤ 2 W
Frequency	50 Hz (± 10%)
<b>Tariff change input (ULYS MD45-M only)</b>	
T1	0 V
T2	230 Vac
<b>Metrological LED</b>	
Weight	10000 pulses/kWh
<b>Pulse output</b>	
Weight	Parameterizable (0.01 - 0.1 - 1 - 10 - 100 - 1000 - 2000 - 10000 pulses/kWh)
Duration	≤ 5 625 W : 32 ms > 5 625 W : 11.2 ms
<b>Accuracy</b>	
Active energy	MID Class B as per EN 50470-1-3
<b>Infrared output</b>	
IR wavelength	900 - 1000 nm
Protocol	IEC 62056-21:2002 (IEC 1107)
<b>Communication (ULYS MD45-M Modbus only)</b>	
Type of bus	RS485
Protocol	MODBUS RTU with 16 bit CRC
Transmission speed	1200, 2400, 4800, 9600bauds/s (by default)
Addresses	0 - 247 (by default: last 2 digits of SN)
Maximum bus load	60
Maximum distance	1 000 meters
Parameterization	Using button on front panel and optical head

## MECHANICAL SPECIFICATIONS

<b>Ingress protection</b>	IP 51 front panel
<b>Power circuit connection</b>	Max 10 mm <sup>2</sup>
<b>Pulse output or communication connection</b>	Max 1.5 mm <sup>2</sup>
<b>Mounting</b>	On 35 mm DIN rail
<b>Weight</b>	80 g

## ENVIRONMENT

<b>Operating temperature</b>	-25 °C to +55 °C
<b>Relative humidity in operation</b>	≤ 75 %

## TO ORDER

To simplify programming of the ULYS MD45 meters, an adapter is supplied with the optical head.

Models	Certification	Communication	Reference
<b>ULYS MD45-M</b>	MID		P01330754
<b>ULYS MD45-M Modbus</b>	MID	RS485 Modbus	P01330756
<b>Accessories</b>			
<b>USB optical head</b>			P01330790

## DIMENSIONS (IN MM)

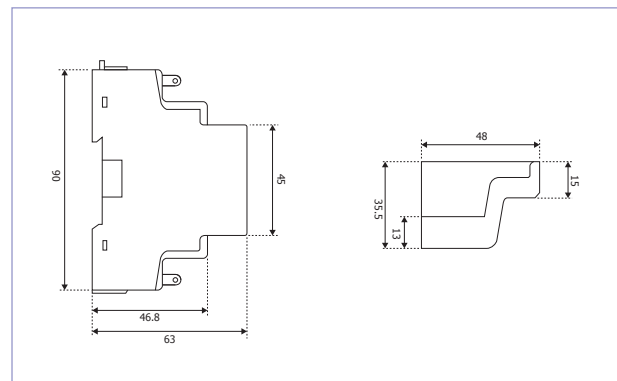

## ELECTRICAL CONNECTIONS

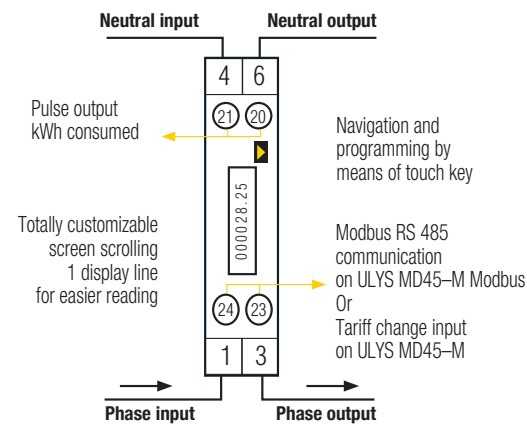

## BLOCK DIAGRAM

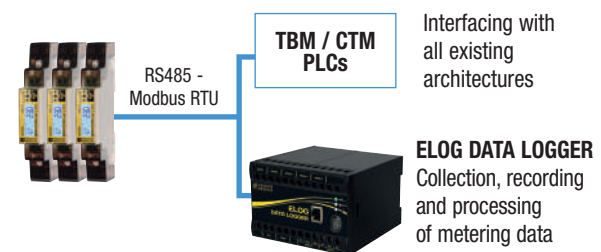

# ULYS MD100

## SINGLE-PHASE 100 A

Energy meter for single-phase networks.  
Direct connection up to 100 A.



### USER SECTORS



Tertiary



Industry



Energy  
efficiency



2 tariffs



Sealable terminal covers  
delivered as standard



Backlit LCD screen

### GENERAL SPECIFICATIONS

**ULYS MD100** is an energy meter designed for use on single-phase networks.

It is the solution dedicated to applications for energy management or electricity rebilling on private networks (MID version).

It is particularly suitable for applications up to 100 A in buildings and shopping malls.

- 2 pulse outputs as standard (weight assignable)
- Direct current inputs up to 100 A
- MID version available for electricity rebilling on private networks
- Tariff-change input (ULYS MD100-M)
- RS485 Modbus communication (ULYS MD100-M Modbus)
- Multi-measurement:
  - Instantaneous quantities: V, I, P, Q, S, PF and F
  - Instantaneous quantities and energy index according to energy directionality and tariff
- Bidirectional energy (consumed and generated)
- Reinitializable partial active energy index

When used with a remote data-retrieval solution and energy management software, your consumption data can be recovered remotely on your PC to automatically generate consumption reports and allocate the consumption fairly.



- MID Class B
- Built-in RS485 Modbus communication
- Reinitializable partial active energy index
- Bidirectional metering
- Double-tariff metering
- Entirely assignable on front panel or optical head
- Customizable multi-measurement display

## ELECTRICAL SPECIFICATIONS

Current input	
Type	direct
Rated current (In)	100 A
Inrush current (Ist)	20 mA
Voltage input	
Rated voltage (Un)	230 Vac (-15% / +10%)
Consumption	≤ 2 W/Phase - ≤ 10 VA/Phase
Frequency	50 Hz ±10 %
Tariff change input (ULYS MD100-M only)	
T1	0 V
T2	230 Vac
Metrological LED	
Weight	10 000 pulses/kWh /kvarh
Pulse output	
Number	2 (kWh import / export)
Weight	10000/2000/1000/100/10/1/0.1/0.01 pulse/kWh
Duration	1 000/100/10/1/0,1/0,01 pulses/kWh 31 ms 2 000 pulses/kWh ≤ 30 kW 31 ms 2000 pulses/kWh > 30 kW 15 ms 10 000 pulses/kWh ≤ 6 kW 31 ms 10 000 pulses/kWh > 6 kW 15 ms 10 000 pulses/kWh >12 kW 5 ms
Accuracy	
Active energy	MID Class B as per EN 50470-1-3
Communication (ULYS MD100-M Modbus only)	
Type of bus	RS485
Protocol	MODBUS RTU with 16 bit CRC
Transmission speed	1200, 2400, 4800, 9600 bauds/s (by default)
Addresses	0 - 247 (by default: last 2 digits of SN)
Maximum bus loads	60
Maximum distance	1000 meters
Parameter settings	Using button on front panel and optical head

## MECHANICAL SPECIFICATIONS

Ingress protection	IP51 front panel
Format	2 DIN modules
Power circuit connection	Screw terminal strip for 35 mm <sup>2</sup> wires
Pulse output or communication connection	Max 1.5 mm <sup>2</sup>
Mounting	On 35 mm DIN rail
Weight	160 g

## ENVIRONMENT

Operating temperature	-25 °C to +55 °C
Relative humidity in operation	≤ 75 %

## TO ORDER

Models	Certification	Reference
ULYS MD100-M	MID	P01330760
ULYS MD100-M Modbus	MID	P01330761

## DIMENSIONS (EN MM)

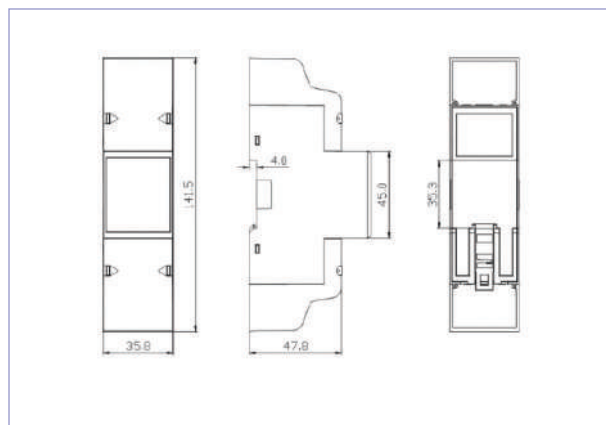

## ELECTRICAL CONNECTIONS

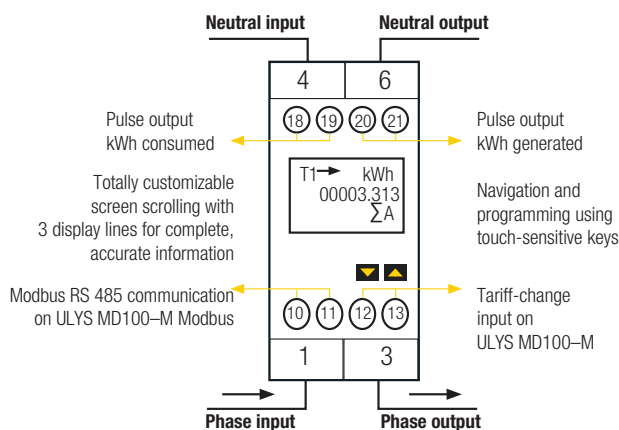

## BLOCK DIAGRAM

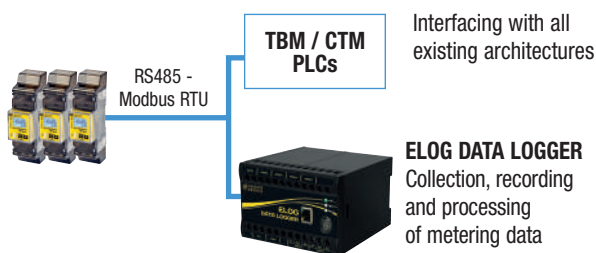

# ULYS TDA80-M

## THREE-PHASE 80 A

Energy meter for three-phase networks. Direct connection up to 80 A. This MID meter is dedicated to energy management or electricity rebilling applications on private networks.



### USER SECTORS



Tertiary



Industry



Energy efficiency



2 tariffs



Measurement in all 4 quadrants with energy balance indicator



2 pulse outputs as standard, assignable to Ea, Eq or Es



- MID Class B
- 4 quadrants
- Multi-measurement
- Compact: only 4 DIN modules

### DESCRIPTION

**ULYS TDA80** is an energy meter designed for use on three-phase networks.

It is the dedicated solution for energy management and electricity rebilling applications on private networks (MID version).

It is particularly suitable for 80 A applications in buildings and shopping malls.

- 2 pulse outputs as standard, assignable to Ea, Eq or Es
- Direct current inputs up to 80 A
- Connection error indicator
- MID version available for electricity rebilling
- Tariff-change input as standard (double tariff)
- Multi-measurement: instantaneous P, Q and S, cumulated and partial energy index (V, U, I, PF, F via ULYSCOM)
- Sealable terminal covers (delivered with seals for the MID version)

## ELECTRICAL SPECIFICATIONS

Current input	
Type	direct
Rated current (In)	(5) 80 A
Inrush current (Ist)	20 mA
Voltage input	
Rated voltage (Un)	3 x 230/400 Vac... 3 x 240/415 Vac (+/- 20 %)
Consumption	7.5 VA max. per phase
Measurement range	0 to 9 999 999.9 kWh
Frequency	50/60 Hz
Tariff change input	
T1	No voltage
T2	80 Vac/Vdc to 276 Vac/Vdc max.
Pulse output	
Type	Optically isolated, 250 Vac/dc
Number	2 assignable as Ea, Eq, ou Es
Weight	100 pulses/kWh, /kVAh, /kVAh
Duration	50 ms
Max. current	100 mA
Accuracy	
Active energy	MID Class B as per EN 50470-1-3
Reactive energy	Class 2 as per IEC 62053-23
Metrological LED	
Weight	1 000 pulses/kWh

## MECHANICAL SPECIFICATIONS

Format	4 DIN modules
Mounting	On 35 mm DIN rail
Connection	Screw terminal strip for 35 mm <sup>2</sup> wires
Ingress protection	Front panel IP51

## ENVIRONMENT

Operating temperature	- 25 °C to +55 °C
Storage temperature	- 25 °C to +75 °C
Relative humidity	Max. 80 % without condensation

## TO ORDER

Model	Certification	Reference
ULYS TDA80-M	MID	P01331018

## DIMENSIONS (MM)

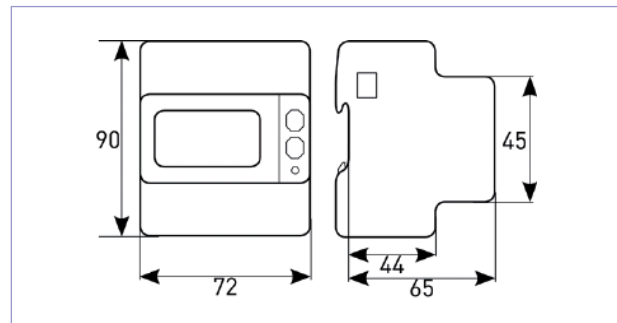

## ELECTRICAL CONNECTIONS

3 wires, 2 currents

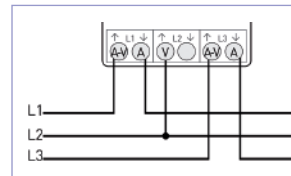

3 wires, 3 currents

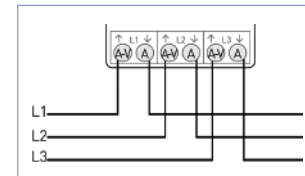

4 wires, 3 currents

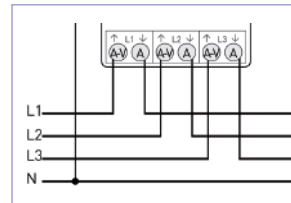

Tariff inputs and pulse outputs

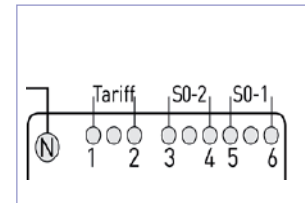

# ULYS TTA-M

## THREE-PHASE WITH CT CONNECTION

Energy meter for three-phase networks.  
CT connection.



### USER SECTORS



Tertiary



Industry



Energy  
efficiency



2 tariffs



Metering on all 4 quadrants  
with energy balance indicato



2 pulse outputs as standard  
assignable to Ea, Eq or Es

### DESCRIPTION

**ULYS TTA** is an energy meter for use in three-phase networks. It is the dedicated solution for energy management applications or electricity rebilling on private networks (MID version).

- 2 pulse outputs as standard features assignable to Ea, Eq or Es
- 1 or 5 A isolated inputs
- Indication of connection errors
- MID version available for rebilling
- Tariff-change input as a standard feature (2 tariffs)
- Multiple measurements: instantaneous P, Q and S, cumulative and partial energy index (V, U, I, PF, F via ULYSCOM)
- Sealable covers (delivered with cable for MID version)



- MID Class B
- Multi-measurement
- Compact: only 4 DIN modules

## ELECTRICAL SPECIFICATIONS

Current input	
Type	On CT 1 or 5 A
Rated current (In)	5 A
Inrush current (Ist)	20 mA
Voltage input	
Rated voltage (Un)	3 x 230/400 Vac... 3 x 240/415 Vac (+/- 20 %)
Consumption	7.5 VA max. per phase
Measurement range	0 to 9 999 999.9 kWh
Frequency	50/60 Hz
Tariff change input	
T1	No voltage
T2	80 Vac/Vdc to 276 Vac/Vdc max.
Pulse output	
Type	Optically isolated, 250 Vac/dc
Number	2 assignable as Ea, Eq or Es
Weight	Automatic adjustment according to CT ratio: from 1,000 pulses/kWh/kVAh to 0.1 pulse/kWh/kVAh
Duration	50 ms
Max. current	100 mA
Accuracy	
Active energy	MID Class B as per EN 50470-1-3
Reactive energy	Class 2 as per IEC 62053-23
Metrological LED	
Weight	1 000 pulses/kWh

## MECHANICAL SPECIFICATIONS

Format	4 DIN modules
Mounting	On 35 mm DIN rail
Connection	Screw terminal strip for 6 mm <sup>2</sup> wires
Ingress protection	IP51 front panel

## ENVIRONMENT

Operating temperature	- 25 °C to +55 °C
Storage temperature	- 25 °C to +75 °C
Relative humidity	Max. 80 % without condensation

## TO ORDER

Model	Certification	Reference
ULYS TDA80-M	MID	P01331018

## ASSOCIATED PRODUCTS



Current transformers  
Cable primary, busbar primary, closed core or split core, etc.  
page 109

## DIMENSIONS (MM)

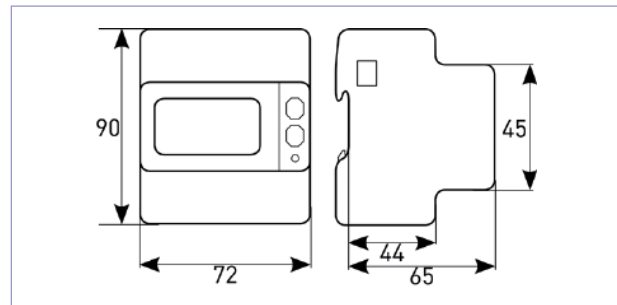

## ELECTRICAL CONNECTIONS

3 wires - 3 CTs

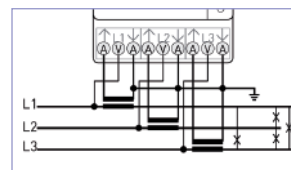

3 wires - 2 CTs

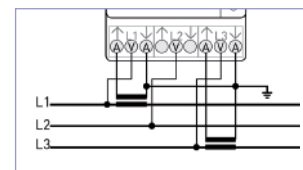

4 wires - 3 CTs

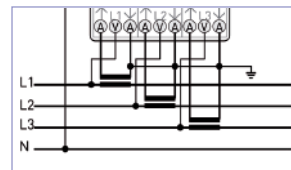

Tariff inputs & pulse outputs

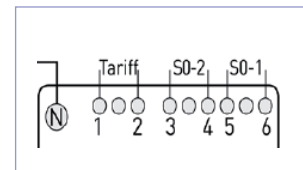

# ULYS TD80

## THREE-PHASE 80 A

WITH INTEGRATED COMMUNICATION

Energy meter for three-phase networks.  
Direct connection up to 80 A.



### DESCRIPTION

**ULYS TD80** is an energy meter designed for use on three-phase networks.

It is an ideal solution for energy management applications or for electricity rebilling on private networks (MID version). It is particularly suitable for 80 A applications in buildings, shopping malls, etc.

- Integrated communication depending on model: Ethernet, M-bus or Modbus
- Small size (4 modules)
- Display customizable by means of predefined user profiles
- 1 pulse output as standard, assignable as P, Q or S
- Direct inputs for current up to 80 A
- Connection error indicator
- MID version available for electricity rebilling
- Tariff-change input as standard (double tariff) except on Ethernet model
- Direct display of multiple measurements: instantaneous P, Q and S, total and partial energy indices, V, U, I, PF, F
- Lead-sealable terminal covers (delivered with cable for MID version)

### USER SECTORS



Tertiary



Industry



Energy efficiency



Built-in communication depending on model:

- Ethernet
- M-Bus
- Modbus



Customizable display of up to 15 electrical quantities



Measurement in all 4 quadrants with energy balance indicator



1 pulse output as standard, assignable as P, Q or S



- **Integrated communication depending on model: Ethernet, M-Bus, Modbus**
- **IEC class 1 / MID class B**
- **4 quadrants**
- **Multiple measurements**
- **Compact: only 4 DIN modules**

## ELECTRICAL SPECIFICATIONS

Current input	
Type	direct
Rated current (In)	(5) 80 A
Istart current (Ist)	20 mA
Voltage input	
Rated voltage (Un)	3 x 230/400 Vac... 3 x 240/415 Vac (+/- 20 %)
Consumption	7.5 VA max. per phase
Frequency	50/60 Hz
Tariff change input (M-bus and Modbus models)	
T1	No voltage
T2	80 Vac/Vdc to 276 Vac/Vdc max.
Pulse output	
Type	Optically isolated 250 Vac/dc
Number	1 assignable as Ea, Eq, ou Es
Weight	100 pulses/kWh, /kVAh, /kVAh
Accuracy	
Active energy	MID Class B as per EN 50470-1-3
Reactive energy	Class 2 as per IEC 62053-23
Metrological LED	
Weight	1000 pulses/kWh
Communication	
Ethernet	IEEE 802.3 standard Modbus TCP, HTTP, NTP and DHCP protocols/Integrated web pages
Modbus	EIA RS485 standard RS485 bus Modbus RTU / ASCII protocol Speed: 300... 57,600 bauds
M-bus	IEC 13757-1-2-3 standard M-bus protocol Speed: 300... 9,600 bauds

## MECHANICAL SPECIFICATIONS

Format	4 DIN modules
Mounting	On 35 mm DIN rail
Connection	Screw terminal strip for 35 mm <sup>2</sup> wires
Protection	Front panel IP51

## ENVIRONMENT

Operating temperature	- 25 °C to +55 °C
Storage temperature	- 25 °C to +75 °C
Relative humidity	Max. 80 % without condensation

## TO ORDER

Model	Certification	Reference
ULYS TD80-M Modbus	MID	P01331036
ULYS TD80-M Ethernet	MID	P01331040

## DIMENSIONS (IN MM)

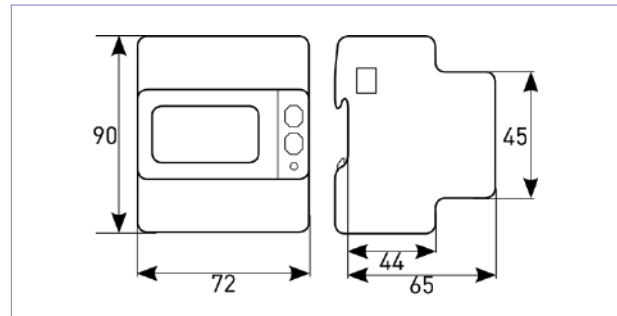

## ELECTRICAL CONNECTIONS

4 wires, 3 currents  
All Models

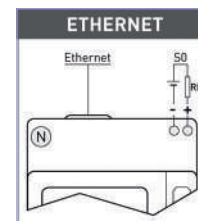
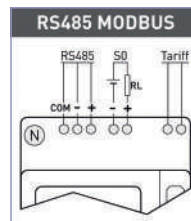
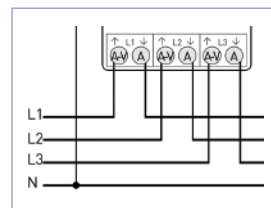

# ULYS TT

## THREE-PHASE CT CONNECTION

WITH INTEGRATED COMMUNICATION

Energy meter for three-phase networks.  
Connection on CT.



### USER SECTORS



Tertiary



Industry



Energy  
efficiency



Built-in communication  
depending on model:

- Ethernet
- M-Bus
- Modbus



Customizable display  
of up to 15 electrical  
quantities



Measurement  
in all 4 quadrants with energy  
balance indicator



1 pulse output as standard,  
configurable as P, Q or S

### DESCRIPTION

**ULYS TT** is an energy meter designed for use on three-phase networks.

It is an ideal solution for energy management applications or for electricity rebilling on private networks (MID version).

- Integrated communication depending on model: Ethernet, M-bus or Modbus
- Small size (4 modules)
- Display customizable by means of predefined user profiles
- 1 pulse output as standard, assignable to Ea, Eq or Es
- 1 or 5 A isolated inputs
- Connection error indicator
- MID version available for electricity rebilling
- Tariff-change input as standard (double tariff) except on Ethernet model
- Direct display of multiple measurements: instantaneous P, Q and S, total and partial energy indices, V, U, I, PF, F
- Lead-sealable terminal covers (delivered with cable for MID version)



- Integrated communication depending on model: Ethernet, M-Bus, Modbus
- IEC class 1 / MID class B
- 4 quadrants
- Multiple measurements
- Compact: only 4 DIN modules

## ELECTRICAL SPECIFICATIONS

Current input	
Type	On CT 1 or 5 A
Rated current (I <sub>n</sub> )	5 A
I <sub>start</sub> current (I <sub>st</sub> )	20 mA
Voltage input	
Rated voltage (U <sub>n</sub> )	3 x 230/400 Vac... 3 x 240/415 Vac (+/- 20 %)
Consumption	7.5 VA max. per phase
Frequency	50/60 Hz
Tariff change input (M-bus and Modbus models)	
T1	No voltage
T2	80 Vac/Vdc to 276 Vac/Vdc max.
Pulse output	
Type	Optically isolated 250 Vac/dc
Number	1 assignable as Ea, Eq, or Es
Weight	Automatic adjustment according to CT ratio: from 1,000 pulses / kWh / kVAh to 0.1 pulse / kWh / kVAh
Accuracy	
Active energy	MID class B according EN 50470-1-3
Reactive energy	Class 2 according to IEC 62053-23
Metrological LED	
Weight	1 000 pulses/kWh
Communication	
Ethernet	IEEE 802.3 standard Modbus TCP, HTTP, NTP and DHCP protocols Integrated web pages
Modbus	EIA RS485 standard RS485 bus Modbus RTU / ASCII protocol Speed: 300... 57,600 bauds
M-bus	IEC 13757-1-2-3 standard M-bus protocol Speed: 300... 9,600 bauds

## MECHANICAL SPECIFICATIONS

Format	4 DIN modules
Mounting	On 35 mm DIN rail
Connection	Screw-on terminal strip for 35 mm <sup>2</sup> wire
Protection	IP51 front panel

## TO ORDER

Model	Certification	Reference
ULYS TT-M Modbus	MID	P01331037
ULYS TT-M Ethernet	MID	P01331041

## ASSOCIATED PRODUCTS



Current transformers  
Cable primary, busbar primary, closed core or split core, etc.  
page 109

## DIMENSIONS (IN MM)

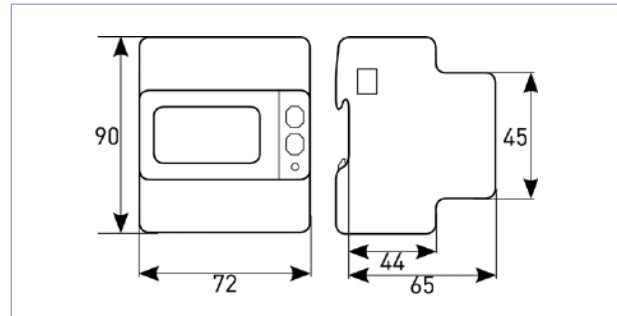

## ELECTRICAL CONNECTIONS

4 wires, 3 currents - All Models

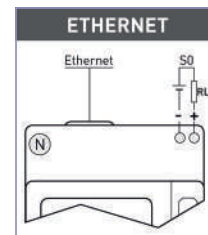
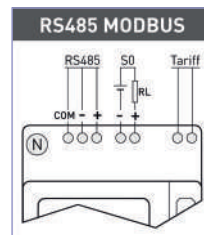
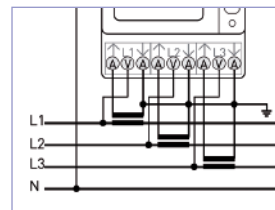

## ENVIRONMENT

Operating temperature	- 25 °C to +55 °C
Storage temperature	- 25 °C to +75 °C
Relative humidity	Max. 80 % without condensation

# ULYS FLEX

## MODBUS

Metering solution on Rogowski coils.



### USER SECTORS



Tertiary



Industry



Energy  
efficiency

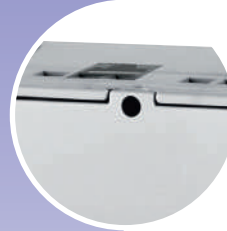

Built-in RS485  
communication



Mounting without cutting  
off the electrical circuit



1 pulse output as standard,  
assignable to Ea, Eq or Es

### DESCRIPTION

- Installation on busbars or conductors with large dimensions or cross-sections
- Possibility of inserting the flexible coils in confined spaces
- Mounting of the ULYS FLEX Modbus without cutting off the electrical feeder
- Accuracy class guaranteed across a large current measurement range (from 5 % to 100 % of full scale)



- Quick implementation
- Reduced installation costs
- Wide dynamic range for measurement (0.3 A to 20,000 A)
- RS485 Modbus RTU communication

### ELECTRICAL SPECIFICATIONS

#### Auxiliary power supply

Voltage range	85 ... 265 V <sub>AC</sub>
Safety	300 V CAT III
Max. consumption	1.6 VA - 1W
Type-T fuse (for external mounting)	250 mA
Frequency	50/60 Hz

#### Voltage measurement

Voltage range	3x10/17 ... 3x285/495 V <sub>AC</sub> — 50/60 Hz
Safety	300 V CAT III
Min. voltage for FFT calculation	20/35 V <sub>AC</sub> (multiplied by the VT ratio) with direct connection

#### Current measurement

Maximum value	3 ratings (FSA) selectable: 500 A (700 A max), 4,000 A (5,600 A max) or 20,000 A (28,000 A max)
Inrush current (IST)	0.3 A for FSA 500 A, 1 A for FSA 4,000 A, 10 A for FSA 20,000 A
Min. current for FFT calculation	70 A for FSA 500 A, 400 A for FSA 4,000 A, 1,500 A for FSA 20,000 A 2 % accuracy of harmonics ± 2 digits

Accuracy	
Voltage	$\pm 0.2\%$ of reading in range from 10 % FS ... FS (FS = full-screen value)
Current	$\pm 0.4\%$ of reading from 5% FS ... FS
Power	$\pm 0.5\%$ of reading $\pm 0.1\%$ FS (PF=1)
Frequency	$\pm 0.1\%$ of reading $\pm 1$ digit in the range 45...65 Hz
Active energy	Class 1 in compliance with IEC/EN 62053-21 (meter + coils)
Reactive energy	Class 2 in compliance with IEC/EN 62053-23 (meter + coils)
Screen & keyboard	
Display	Backlit LCD, 43 x 29 mm - 3 lines, 4 digits + symbols
Keyboard	3 keys + 1 protected button
Communication port	
Type	Optically isolated RS485
Protocols	MODBUS RTU/ASCII
Baud rate	300 ... 57,600 bps
Digital output (DO)	
Type	Passive optically-isolated polarized electronic output
Maximum values (compliant with IEC/EN 62053-31)	27 V <sub>DC</sub> - 27 mA
Energy pulse length (for DO in Pulse mode)	50 $\pm$ 2 ms ON time
Maximum frequency	8 pulses per sec (8 Hz)
Maximum reaction time (for DO in Alarm mode)	1 s

## DIMENSIONS (MM)

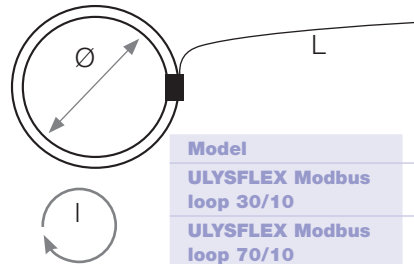
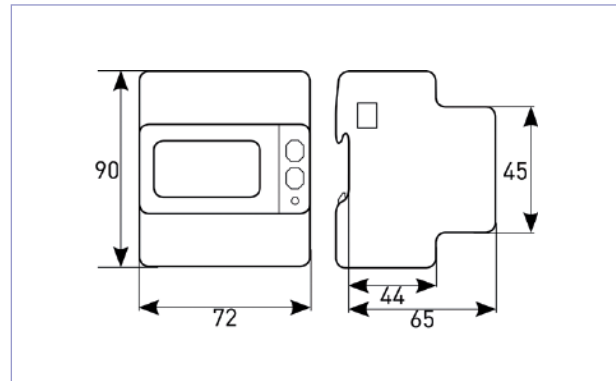

Model	l (cm)	Ø (cm)	L (m)
ULYSFLEX Modbus loop 30/10	30	10	10
ULYSFLEX Modbus loop 70/10	70	22	10

## MECHANICAL SPECIFICATIONS

Dimensions LxHxW	72 x 90 x 65 mm
Weight	436 g
Connection	Measurement terminal strip (A & V): 1.5 ... 6 mm <sup>2</sup> Terminal strips for digital output, power supply and RS485 port: 0.14 ... 2.5 mm <sup>2</sup>
Ingress protection	IP51 front panel - IP 20 terminal strips
Pollution degree	2

## ENVIRONMENT

Operating temperature	- 25 °C to +55 °C
Storage temperature	25 °C to +75 °C
Relative humidity	Max. 80 % without condensation
Product operating altitude	< 2 000 m
Vibration or shock (sinusoidal amplitude)	50 Hz $\pm$ 0.075 mm

## STANDARDS

Directives	2066/95/EC, 2004/108/EC
Safety	EN61010-1, EN 61010-2-030, EN 61010-2-032
Electromagnetic compatibility (EMC)	EN61326-1, EN 55011, EN 61000-4-2, EN 61000-4-3, EN 61000-4-4, EN 61000-4-5, EN 61000-4-6, EN 61000-4-11, EN 61000-6-2

## ELECTRICAL CONNECTIONS

Three-phase  
4 wires, 3  
Rogowski  
coils

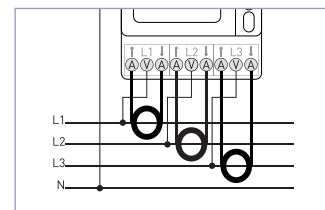

Three-phase  
3 wires, 2  
Rogowski coils

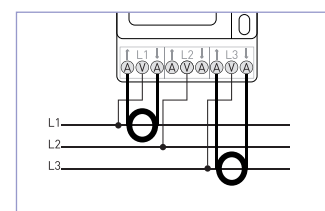

Single-phase,  
1 Rogowski coil

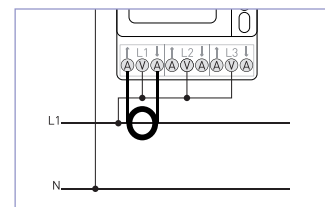

## TO ORDER

Models	Reference
ULYSFLEX Modbus boucle 30/10	P01331048
ULYSFLEX Modbus boucle 70/10	P01331049

# ULYS MCM

## MULTI-CHANNEL METER

Multi-channel power monitor and energy meter



### USER SECTORS



Industry



Energy generation



Energy transmission & distribution



Energy efficiency

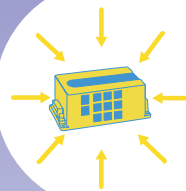

18 meters in one



Compact



Compatible with a large number of sensors



- Compact: 18 meters in one!
- Quick to set up
- Wide range of sensors for any type of conductor and current
- Comprehensive measurement of all the electrical parameters
- Flexible communication

### DESCRIPTION

**Ulys MCM** is the innovative solution for centralizing measurements on multiple electrical feeders:

- Compact
- Compatible with all power ratings
- Quick connection
- Easy to integrate

The Ulys MCM is available in versions with 9 or 18 three-phase measurement channels.

### ACCESSORIES



#### CURRENT SENSORS

Clip-on current transformers (5 sizes available) and MiniFlex flexible sensors based on Rogowski technology.



#### ADAPTER FOR CURRENT SENSORS

Supplied directly when you purchase a pack of 3 current sensors.



#### SCREEN

Supplied directly when you purchase a pack of 3 current sensors

## TECHNICAL SPECIFICATIONS

Feature	Specifications	
<b>Electrical system</b>	1P2W, 3P3W, 3P4W	
<b>Spécifications nominales des entrées</b>	<b>Voltage (Umin – Umax)</b>	43-690 V~ between phases
	<b>Voltage (Vmin – Vmax)</b>	25-400 V~ between phases and neutral
	<b>Measurement category</b>	600 V Cat III
	<b>Frequency</b>	45-65 Hz
	<b>Current</b>	0-333 mA (max 0.5 V p-p)   Impedance: 20 kΩ
	<b>On-off (DI)</b>	1 point, 80-250 V~, external power supply
	<b>NTC temperature</b>	25°C, 10 kΩ, (β(25/85)=3 970°k)
<b>Auxiliary power supply</b>	<b>Voltage</b>	100-240 V~
	<b>Frequency</b>	50-60 Hz
	<b>Max. voltage (L-N)</b>	Short term: 1,440 V~ Long term: 490 V~
	<b>Consumption</b>	0.05-0.08 A
	<b>Overvoltage category</b>	300 V Cat II
<b>Communication</b>	Modbus RS485	
	Modbus TCP	
	RS232	
<b>On-off output contact (DO)</b>	1 NO (normally open) SPST (single pole, single throw)	

## MEASUREMENT PERFORMANCE SPECIFICATIONS

Quantity	Standard	ULYS MCM	ULYS MCM and MF300/MF300
<b>Active power (P) measurements</b>	IEC 61557-12 : 2018	0.5	1
<b>Active energy (Ea)</b>	IEC 61557-12 : 2018		
	IEC 62053-21 : 2003 IEC 62053-22 : 2003	0.5	1
<b>Reactive power (Q) measurements</b>	IEC 61557-12 : 2018	1	2
<b>Reactive energy (Er)</b>	IEC 61557-12 : 2018		
	IEC 62053-23 : 2003	2	2
<b>RMS line current (I) measurements</b>	IEC 61557-12 : 2018	0.2	0.5
<b>RMS voltage measurements (U/V)</b>	IEC 61557-12 : 2018	0.1	0.1

## SOFTWARE

Ulys MCM UTILITY is the software for managing the ULYS MCM. It can be used for:

- Electrical configuration of the Ulys MCM (voltages and currents of each electrical feeder, etc.)
- Configuration of the Ulys MCM's communication (address, type of communication, etc.) and diagnostics
- Storage of the configuration file to import/ export them from one product to the other
- Real-time display of the general quantities and electrical values across all the channels

Ulys MCM UTILITY can be downloaded directly from our website.

## ELECTRICAL QUANTITIES MEASURED

Quantity	Unit	Range
Phase-to-neutral voltage	V	0.00 - 9 999 999.99
Phase-to-phase voltage	V	0,00 - 9 999 999.99
Current	A	0,00 - 9 999 999.99
Active power	W	±0 - 999 999 999
Reactive power	Var	±0 - 999 999 999
Apparent power	VA	0 - 999 999 999
Frequency	Hz	45.00 - 65.00
Power factor	%	± 100.00
NTC temperature	°C	-20.0 - 100.00
Voltage unbalance	%	0.0 - 100.00
Current unbalance	%	0.0 - 100.00
Phase shift angle	°	0.0 - 360.00
Total Harmonic Distortion*	%	0.0 - 100.00
Active energy	KWh	0.0 - 99 999 999.9
Reactive energy	KVarh	0.0 - 99 999 999.9
Apparent energy	KVAh	0.0 - 99 999 999.9

\*Power equivalent: please refer to user's manual

## INSTALLATION CONDITIONS

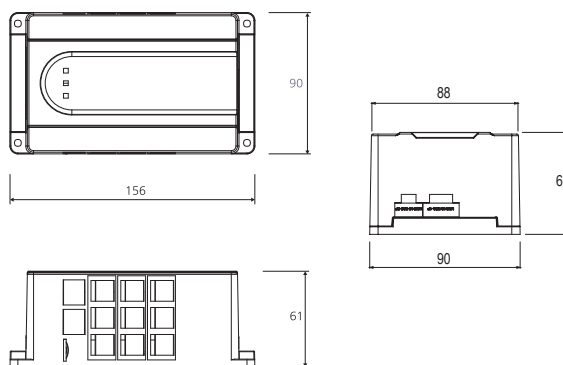

Description	Condition
Temperature	-10°C to +55°C (nominal operating range) -25°C to +70°C (storage range)
Relative humidity	5-80 % RH without condensation
Altitude	≤ 2,000 m
Degree of pollution	2
Location	Indoors

## CONNECTION

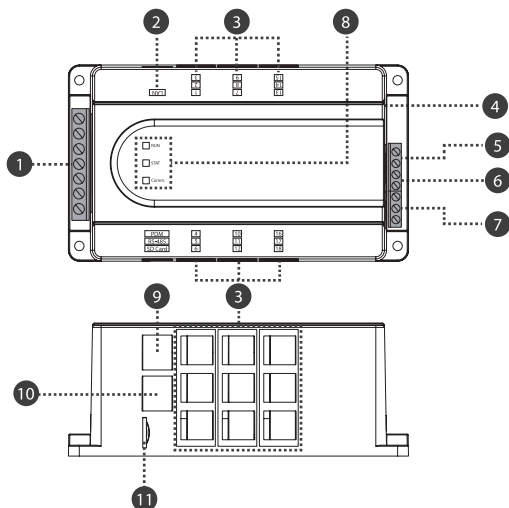

No	Designation	Description
1	Input voltage	Input voltage terminal for the measurements
2	Ethernet port	Communication with master (Modbus slave) Protocol: Modbus TCP/IP Speed: 10/100 Mbit/s
3	CT 1 to 18 port	RJ12 connectors for connection to the current sensor
4	Temperature sensor	NTC temperature sensor: NTC temperature measurement at the level of the port
5	Output	On-off output terminal Rated specifications: 250 V~/5 A, 30 Vp-p/5A resistive
6	On-off input	On-off output terminal Rated specifications: 80-250 V~ locking voltage required
7	Auxiliary power supply	ULYS MCM auxiliary power supply
8	Status LED	RUN: normal operation STAT: normal metering Comm: normal communication (flashing LED in normal status)
9	RS232 port	Communication with the PC or ULYS MCM D remote display
10	RS485 port	RS485 port for connecting the PC or an external PLC
11	SD card slot	Do not disconnect the card: the system makes use of it

## CONNECTION OF THE VOLTAGE MEASUREMENT INPUTS

### Wiring of 4-wire three-phase system

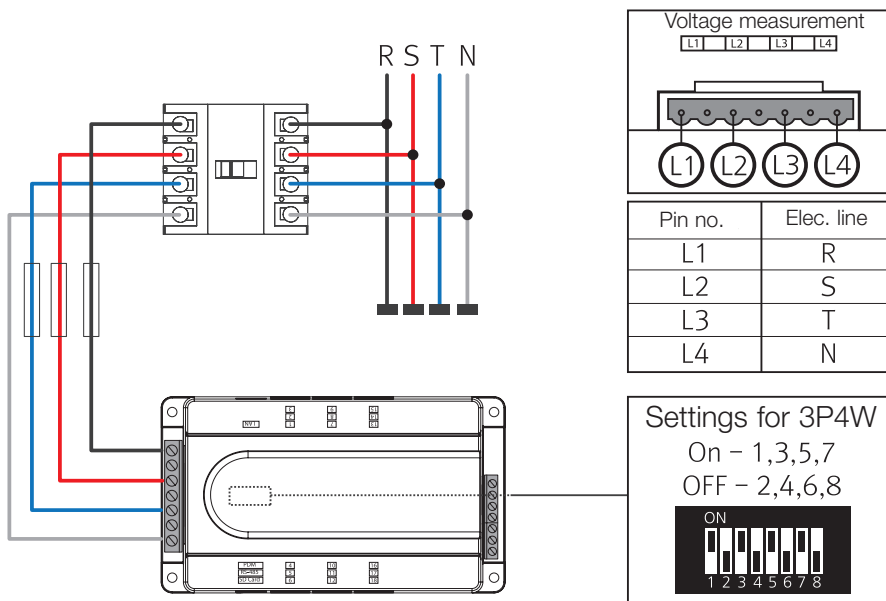

### Wiring of 3-wire three-phase system

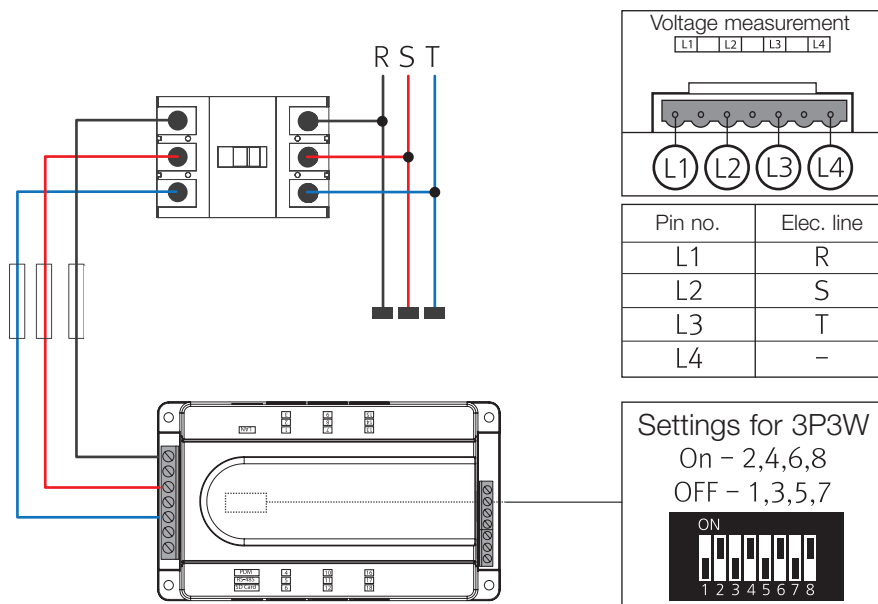

#### TO ORDER

Models	Reference
ULYS-MCM6	P013310615
ULYS-MCM9	P01331062
ULYS-MCM18	P01331064
ULYS-MCM	P01331068 - DIN RAIL MOUNTING ACCESSORY FOR ULYS MCM

# ACCESSORIES

## CURRENT SENSORS

OUR SENSORS ARE DELIVERED IN PACKS OF 3 DIRECTLY CONNECTED TO THE CONNECTION ADAPTER (CODE P01379643)

MF300 and MF3000 openable flexible current sensors (Rogowski coils)



### GENERAL SPECIFICATIONS

<b>Measurement range</b>	MF300 : 2,4 A to 600 A MF3000 : 2,4 A to 3 000 A
<b>Output</b>	39,1 $\mu$ V/A
<b>Accuracy (current measurement)</b>	Class 0.5 as per IEC 61557-12 (complete ULYS MCM measurement line and coils)
<b>Output connections</b>	HY-Y type

### MECHANICAL SPECIFICATIONS

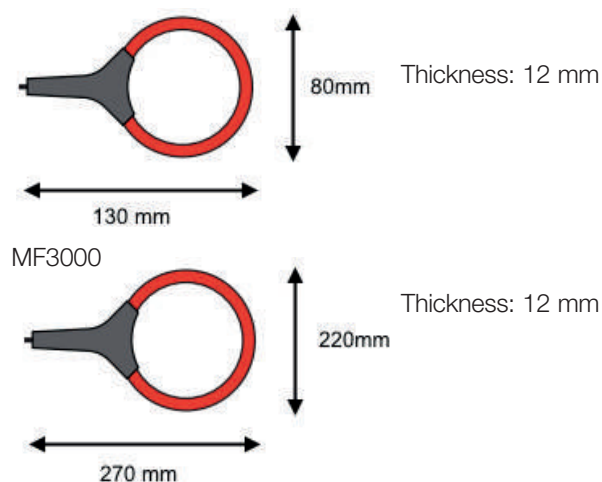

<b>Clamping diameter</b>	MF300: length = 250 mm; $\varnothing$ = 70 mm MF3000: length = 350 mm; $\varnothing$ = 200 mm
<b>Length of linking cable (between the output connection and the coil)</b>	1.5 meters
<b>Protection provided by the enclosures</b>	IP50 as per IEC 60529
<b>Protection against mechanical impacts</b>	IK04
<b>Weight</b>	MF300: 60 g approx. MF3000: 90 g approx.

TC CLIP sensors : TCC V 105, TCC V 161, TCC V 242, TCC V 364, TCC V 366

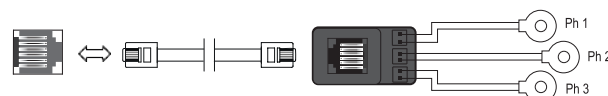

### GENERAL SPECIFICATIONS

<b>Nominal current (In)</b>	TCC V 105 : 5 A TCC V 1050 : 50 A TCC V 161 : 100 A TCC V 242 : 250 A TCC V 364 : 400 A TCC V 366 : 600 A
<b>Clamping diameter</b>	TCC V 105 : 10 mm TCC V 1050 : 10 mm TCC V 161 : 16 mm TCC V 242 : 24 mm TCC V 364 : 36 mm TCC V 366 : 36 mm
<b>Frequency</b>	50-60 Hz
<b>Output</b>	333 mV
<b>Accuracy (current measurement)</b>	Class 0.5 from 100 to 120 % of In as per IEC 61869-2 Class 1 from 20 to 120 % of In
<b>Accuracy (current measurement)</b>	Type HY-Y

### MECHANICAL SPECIFICATIONS

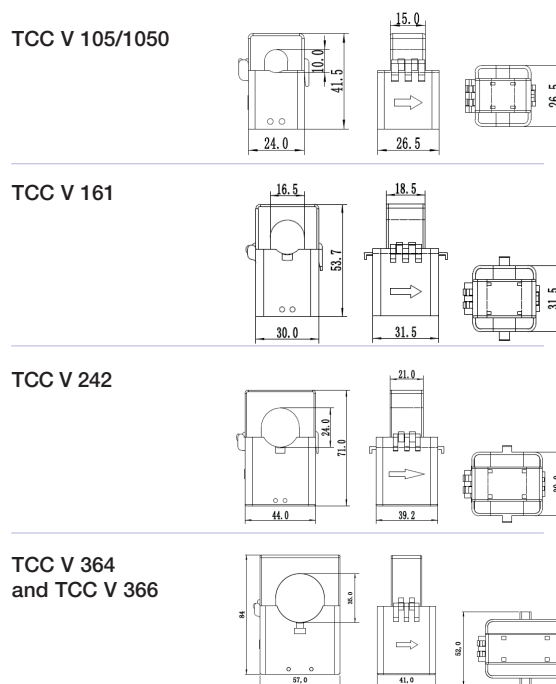



MECHANICAL SPECIFICATIONS

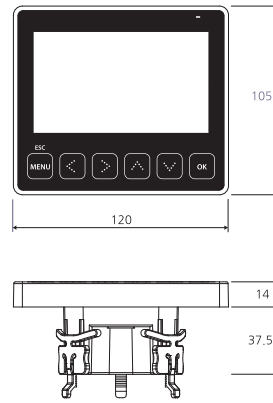

GENERAL SPECIFICATIONS

Feature	Specifications	
Power supply	5 Vdc (self-powered by the ULYS MCM)	
Electrical consumption	1.2 W	
Dimensions (mm)	120 (L) x 105 (H) x 50 (W)	
Weight	196 g	
Mounting	Mounting on electrical cabinet / portable use	
Operating conditions	Operating temperature: -10°C to +55°C Storage temperature: -25°C to +70°C Humidity range: 5 to 80 % without condensation Altitude: ≤ 2,000 m	
Key	Screen	4.3 inch LCD TFT screen (480 (W) x 272 (H) mm
	ESC/MENU	Back to previous menu or cancel / Access parameters menu
	LEFT	Move left
	RIGHT	Move right
	UP	Move up
	DOWN	Move down
OK	Modify the selection or display mode of the channel	

CUT-OUTS

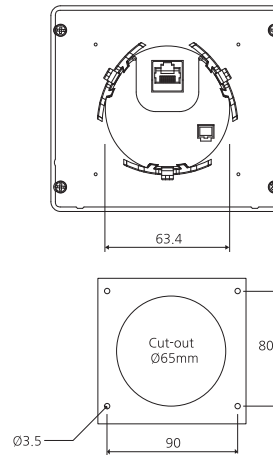

TO ORDER

WHICH SENSORS DO YOU WANT?

(may be different for each feeder, in kits of 3)

	Ratio	Diameter	
<b>Rigid sensors</b>			
PACK 3 TCC V 105	5A / 333mV	10mm	P01 379 616
PACK 3 TCC V 1050	50A / 333mV	10mm	P0 1379 626
PACK 3 TCC V 161	100A / 333mV	16mm	P01 379 618
PACK 3 TCC V 242	250A / 333mV	24mm	P01 379 620
PACK 3 TCC V 364	400A / 333mV	36mm	P01 379 622
PACK 3 TCC V 366	600A / 333mV	36mm	P01 379 624
<b>Flexible sensors</b>			
PACK 3 MF300	600A / (39,1µV/A)	70mm	P01 379 631
PACK 3 MF3000	3000A / (39,1µV/A)	200mm	P01 379 633

A pack comprises 3 TCCLIPs or 3 Rogowski coils with the adapter for connection of the RJ12M-RJ12M extension (3 or 9 meters).

DO YOU WANT TO EQUIP YOUR ULYS MCM WITH A DISPLAY?

P01331065	ULYS MCM D	DISPLAY UNIT
P01379640	RJ45M-RJ45M M	Linking cable*

\*Cable essential for connection of the display

WHAT WILL THE DISTANCE BE BETWEEN YOUR ULYS MCM AND YOUR SENSORS?

P01379641	RJ12M-RJ12M M	< 3 meters
P01379642	RJ12M-RJ12M L	< 9 meters

# ULYS MD45-M EV

## 45 A SINGLE-PHASE

WITH BUILT-IN COMMUNICATION

Energy meters for single-phase networks.  
Direct connection up to 45 A.

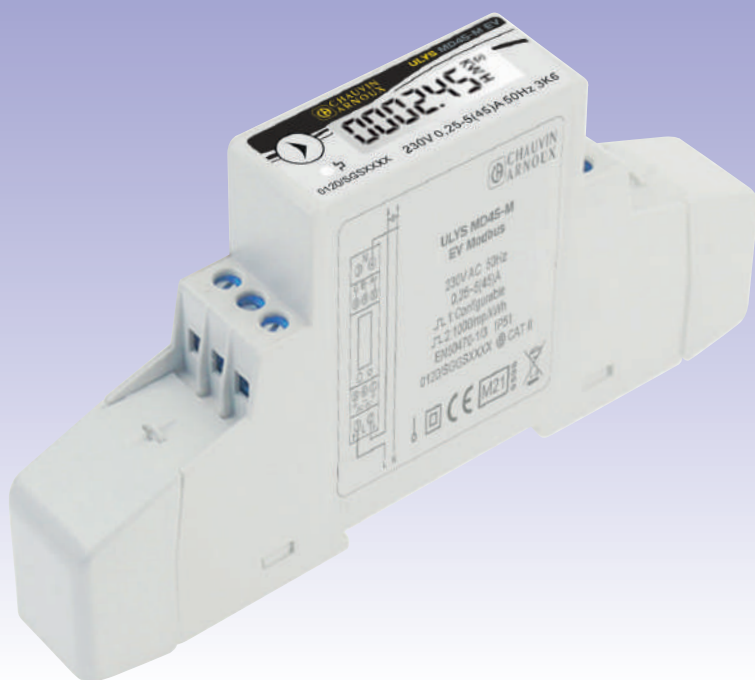

### USER SECTORS



Tertiary



Industry



Energy  
efficiency



Intuitive navigation



Direct connection up  
to 45A



Lead-sealable terminal covers  
delivered asstandard

### DESCRIPTION

Designed for electric vehicle AC recharging applications requiring MID certification for energy rebilling, the Ulys MD45-M EV Modbus meter can be used to cover any type of single-phase grid and station power rating: Wallbox, roadside charging station, private fleet recharging, etc.

The meter can be used locally with its screen or remotely via its built-in communication.

Particularly suitable for single-phase charging station from 3 kW to 7 kW, the Ulys MD45-M EV Modbus offers the following features:

- 1 DIN module
- Single-phase 45A direct (40A used)
- Class 1
- MID-certified
- Measurements:
  - Voltage, current, frequency, Power Factor
  - Active power, reactive power
  - Active energy drawn and injected, reactive energy
- Modbus RS485 communication
- Operating temperature: -40 to +70 °C



- Compact meter with built-in Modbus RS485 communication
- Direct connection between the network and the socket: 45A single-phase
- Complies with the MID Class B regulations

## ELECTRICAL SPECIFICATIONS

Current input	
Rated current (I <sub>max</sub> )	45 A
Reference current (I <sub>ref</sub> )	5A
Inrush current (I <sub>st</sub> )	20 mA
Voltage input	
Rated voltage (U <sub>n</sub> )	230 Vac (-15% / +10%)
Consumption	≤ 2 W/Phase - ≤ 10 VA/Phase
Rated frequency	50 Hz (± 10%)v
Metrological LED	
Weight	10000 pulses/kWh
Pulse output	
Weight	10000/ 2000/ 1000/ 100/ 10/ 1/ 0.1/ 0.01 pulses/kWh
Pulse width	≤ 5 625 W : 32 ms > 5 625 W : 11.2 ms
Max. operating voltage	5 -27 Vdc
Max. admissible current	≤ 27 mAdc
Communication	RS485 Modbus
Data backup	10 years with power off
Accuracy class	MID (Class 1)
Accuracy	
Active energy	Total, partial, import, export
Reactive energy	Total, import, export
Multi-measurement	P, Q, S, V, I, PF, F
Bidirectional	Yes

## DIMENSIONS (MM)

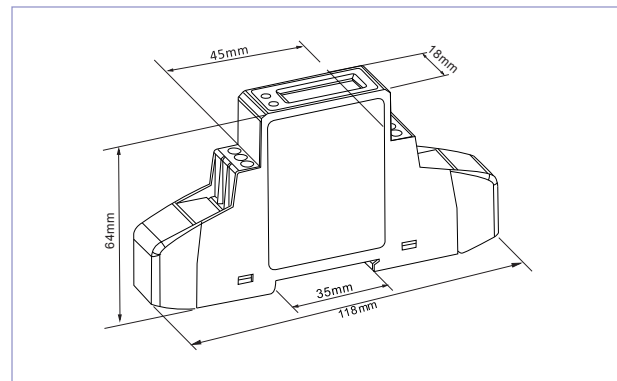

## ELECTRICAL CONNECTIONS

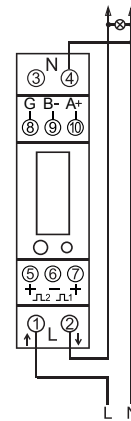

## MECHANICAL SPECIFICATIONS

Ingress protection	IP51
Power circuit connection	10 mm <sup>2</sup>
Pulse output or communication connection	1.5 mm <sup>2</sup>
Mounting	On 35 mm DIN rail
Weight	80 g

## ENVIRONMENT

Operating temperature	-40°C to +70°C
Relative humidity in operation	≤ 75% / ≤ 95%

## TO ORDER

Model	Certification	Reference
ULYS MD45-M EV Modbus	MID	P01331081

# ULYS TD100-M EV

## 100 A THREE-PHASE

WITH BUILT-IN COMMUNICATION

Energy meter for three-phase networks.  
Direct connection up to 100 A.



### USER SECTORS



Tertiary



Industry



Energy  
efficiency



Captive terminal cover



Direct terminal  
up to 100A



Intuitive navigation

### DESCRIPTION

Designed for electric vehicle AC recharging applications requiring MID certification for energy rebilling, the Ulys TD100-M EV Modbus meter can be used to cover any type of three-phase grid and station power rating: Wallbox, roadside charging station, private fleet recharging, fast charging, etc.

The meter can be used locally with its screen or remotely via its built-in communication.

Particularly suitable for three-phase charging station from 11kW to 43kW, the Ulys TD100-M EV Modbus offers the following features:

- 4 DIN modules
- Three-phase 100A direct (40A used)
- Class 1
- MID-certified
- Measurements:
  - Voltage, current, frequency, Power Factor
  - Active power, reactive power
  - Active energy drawn and injected, reactive energy
- Modbus RS485 communication
- Operating temperature: -40 to +70 °C



- Compact meter with built-in Modbus RS485 communication
- Direct connection between the network and the socket: 100A three-phase
- Complies with the MID Class B regulations

## ELECTRICAL SPECIFICATIONS

<b>Current input</b>	
Rated current (I <sub>max</sub> )	100 A
Reference current (I <sub>ref</sub> )	10A
Inrush current (I <sub>st</sub> )	40 mA
<b>Voltage input</b>	
Rated voltage (U <sub>n</sub> )	230 Vac (-15% / +10%)
Consumption	≤ 2 W/Phase - ≤ 10 VA/Phase
Frequency	50 Hz (± 10%)
<b>Metrological LED</b>	
Weight	1000 pulses/kWh
<b>Pulse output</b>	
Weight	1000/ 100/ 10/ 1 pulses/kWh
Pulse width	35 ms
Max. operating voltage	5 -27 Vdc
Max. admissible current	≤ 27 mA <sub>dc</sub>
Communication	RS485 Modbus
Data backup	10 years (powered down)
Accuracy class	MID (Class 1)
<b>Accuracy</b>	
Active energy	Total, partial, import, export
Reactive energy	Total, import, export
Multi-measurement	P, Q, S, V, I, PF, F
Bidirectional	Yes

## MECHANICAL SPECIFICATIONS

<b>Ingress protection</b>	IP51
<b>Power circuit connection</b>	16 mm <sup>2</sup>
<b>Pulse output or communication connection</b>	1.5 mm <sup>2</sup>
<b>Mounting</b>	On 35 mm DIN rail
<b>Weight</b>	80 g

## ENVIRONMENT

<b>Operating temperature</b>	-40°C to +70°C
<b>Relative humidity in operation</b>	≤ 90% / ≤ 95%

## TO ORDER

<b>Model</b>	Certification	Reference
<b>ULYS TD100-M EV Modbus</b>	MID	P01331083

## DIMENSIONS (IN MM)

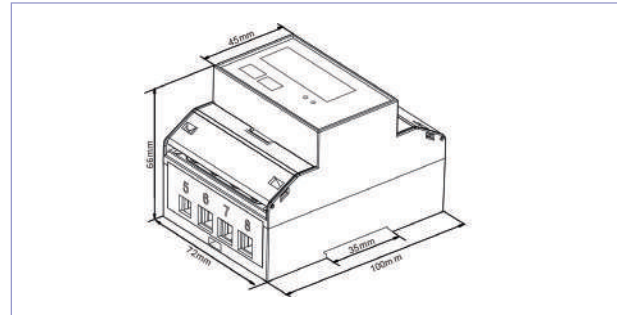

## ELECTRICAL CONNECTIONS

### Single-phase with two wires

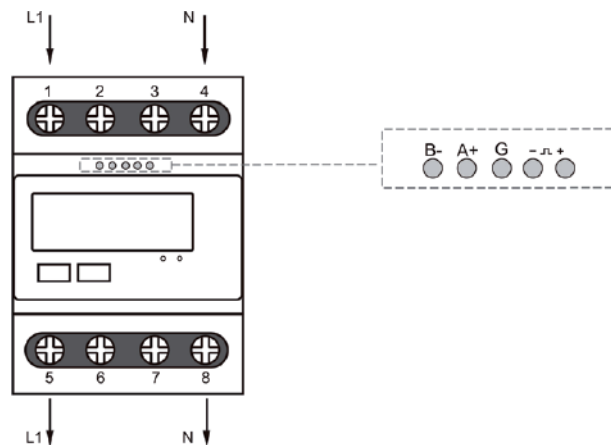

### Three-phase with four wires

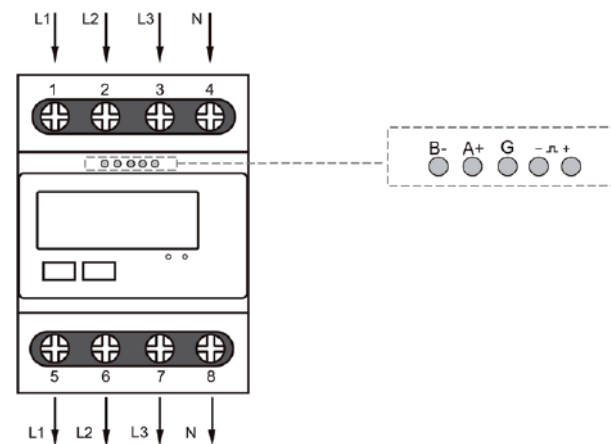

# ALTYS

## TARIFF METER

4-quadrant tariff meter for MV customers.



### USER SECTORS



Energy transmission & distribution

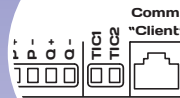

Customer communication access

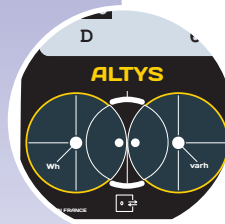

High-speed optical interface



Standardized protocol

### DESCRIPTION

The electronic **ALTYS** meter is intended for installation on consumer or producer sites connected to the MV electrical network.

The ALTYS meter should be viewed in the context of deregulation of the electricity market which led to the end of regulated pricing in France on 31/12/2015. It has been designed to handle tariff offers proposed by any electricity supplier.

The **ALTYS** meter offers the following main functions:

- Measurement of the energy values in both transit directions
- Management of two tariff frameworks independently: one Distributor framework and one Supplier framework
- Management of dynamic tariffs for each of the two tariff frameworks
- Storage of the load curves of the active and reactive energy consumed and produced, as well as the voltage supervision curve
- Simultaneous communication access to the distribution network manager and the customer



- MID class C
- Measurement on all 4 quadrants
- DLMS COSEM protocol
- Local upgrading of the application software
- 2 tariff frameworks
- Dynamic pricing
- Customer communication and customer information (CIS) outputs
- Calculation and storage of faults (dips, outages and voltage surges)
- Load and voltage curves

## GENERAL SPECIFICATIONS

### Metrological functions

- Index of consumed and produced energy values by tariff item
- Calculation of the power and energy overrun values in relation to the contractual power values
- Calculation of the average power values (5 or 10 min interval)
- Calculation of the operating times in each tariff period, for consumption and production
- Integration of Joule and Core losses
- Presentation of the data on the display

### Tariff functions

- 2 tariff frameworks (Distributor and Supplier)
- 8 tariff items definable per framework
- Management of dynamic pricing by external contact or by programming

### Qualimetry functions

- Calculation of the types of faults (voltage dip, outage or surge) according to their amplitude and the contractual thresholds programmed
- Storage of the fault characteristics (start date, end date, duration)

### Interfaces

- DLMS Cosem operator communication
- Tariff change input
- Pulse outputs for active and reactive energy: CM, P+, P-, Q+, Q-
- Time pulse output: TP1- TP2
- DLMS Cosem customer communication
- Remote customer information (CIS)
- High-speed optical interface for programming, data retrieval and local upgrading of the meter's application software

### LED indicators

- Voltage presence and energy flow direction LEDs per phase
- Control mode / test mode LED
- Fault LED
- Metrological LED for active energy
- Metrological LED for reactive energy

## DISPLAY et LEDs

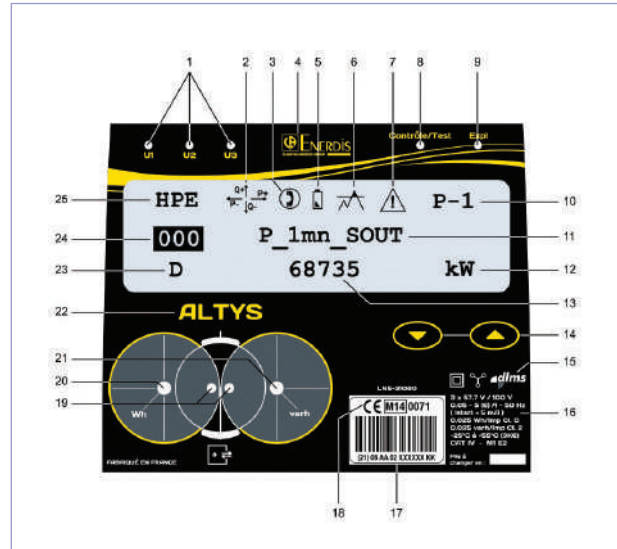

- 1 - Voltage Presence LED - Fixed: Voltage present; Flashing: consumption
- 2 - Current flow direction - Real flow, without correction
- 3 - Communication pictogram - Fixed: in progress; Flashing: establishing 4 Manufacturer (Chauvin Arnoux Energy)
- 5 - Low Battery pictogram - Please refer to the corresponding chapter
- 6 - Overrun pictogram
- 7 - No Tariff Application pictogram  
If this pictogram lights up, contact your correspondent
- 8 - Control Mode / Test Mode LED
- 9 - Expl LED - LED reserved for the Operator
- 10 - Data item period
- 11 - Data item label
- 12 - Data item unit
- 13 - Data item value
- 14 - Navigation buttons - Used to navigate among the data on the meter
- 15 - Legal markings & Certification
- 16 - Operating range
- 17 - Serial number
- 18 - CE & MID marking
- 19 - Access to 62056-21 optical head
- 20 - Active Energy metrological LED  
In Wh, on the secondary, without taking the losses into account
- 21 - Reactive Energy metrological LED  
In varh, on the secondary, without taking the losses into account
- 22 - Meter name
- 23 - Framework to which the data item belongs 24 Number of data item
- 25 - Current supplier tariff item

## ELECTRICAL SPECIFICATIONS

<b>Accuracy class</b>	
<b>Active energy</b>	MID class C as per EN 50470-1-3
<b>Reactive energy</b>	Class 2 as per IEC 62053-23
<b>Network</b>	
<b>Type</b>	Three-phase 4 wires
<b>Current inputs</b>	
<b>Type</b>	On CT
<b>Rated current</b>	5 A (6.5 A max)
<b>Inrush current</b>	5 mA
<b>Consumption</b>	< 0.5 VA par phase
<b>Voltage inputs</b>	
<b>Rated voltage</b>	57.7 V / 100 V
<b>Frequency</b>	50 Hz
<b>Operating range</b>	75% to 110% of rated voltage
<b>Consumption</b>	2 W / 10 VA per phase
<b>Auxiliary power supply</b>	
<b>Type</b>	Self-powered
<b>Tariff change input (C-C1)</b>	
<b>Characteristics</b>	230 V – 50 Hz
<b>Function</b>	Application of a signal on this input will switch the meter to "dynamic" or "mobile peak" pricing
<b>Pulse outputs</b>	
<b>Number</b>	4
<b>Quantities assigned</b>	P+ / P- / Q+ / Q-
<b>Characteristics</b>	27 Vp-p / 27 mA max 1 pulse every 0.025 Wh
<b>Weight</b>	This weight should be multiplied by the coefficient CT x VT to obtain a snapshot of the primary energy
<b>Time pulse output</b>	
<b>Characteristics</b>	230 V / 2 A – 50 Hz
<b>Function</b>	Closure for approx. 900 ms indicates that integration of the previous average power has been completed
<b>Operator communication</b>	
<b>Connections</b>	RJ45
<b>Type</b>	RS232 (specific cable not supplied with the meter)
<b>Protocol</b>	DLMS Cosem as per IEC 62056 Reserved for Operator: Data retrieval and programming of the meter / Connection of an external modem (STN, GSM, GPRS, etc.)
<b>Function</b>	
<b>Customer communication</b>	
<b>Connections</b>	RJ45
<b>Type</b>	RS232 (specific cable not supplied with the meter)
<b>Protocol</b>	DLMS Cosem as per IEC 62056 Reserved for Operator: Data retrieval and programming of the meter / Connection of an external modem (STN, GSM, GPRS, etc.)
<b>Function</b>	
<b>Customer information (CIS)</b>	
<b>Connections</b>	RJ45
<b>Type</b>	RS232
<b>Characteristics</b>	Min 100 Ω / Max 5 V
<b>Communication mode</b>	Unidirectionnel
<b>Function</b>	Allows connection of an Energy Manager / cyclical generation of information for the customer
<b>High-speed optical interface</b>	
<b>Reference standard</b>	IEC 62056-21
<b>Function</b>	Retrieval of metering data, programming and local upgrading of the meter's application software

## MECHANICAL SPECIFICATIONS

<b>Format</b>	330 mm x 180 mm x 100 mm
<b>Weight</b>	Meter alone: 2 kg / Meter in packaging: 3 kg
<b>Mounting</b>	Surface mounting / attached at 3 points
<b>Ingress protection</b>	IP 51
<b>Access protection</b>	By seals
<b>Power terminal strip</b>	Cable cross-section: 4 mm <sup>2</sup> / Max. tightening torque: 0.6 Nm
<b>Input and output terminal strips</b>	Collet capacity: 2.5 mm <sup>2</sup> / Max. tightening torque: 0.5 Nm

## ENVIRONMENT

<b>Climatic</b>	
<b>Rated operating temperature</b>	-25°C to +55°C
<b>Storage temperature</b>	-28°C to +70°C
<b>Relative humidity</b>	Max 80%
<b>Electrical</b>	
<b>Overvoltage category</b>	II

## CONNECTIONS

<b>Operator access</b>	
<b>Terminals</b>	<b>Functions</b>
<b>Comm. "Expl"</b>	Two-way "Operator" interface
<b>C, C1</b>	Input circuit for tariff change

<b>Customer access</b>	
<b>Terminals</b>	<b>Functions</b>
<b>P+, P-, Q+, Q-, CM</b>	Pulse output contacts
<b>TP1, TP2</b>	Time pulse output contacts
<b>"Client" communication</b>	Two-way "Customer" interface
<b>"TIC"</b>	One-way CIS customer information interface

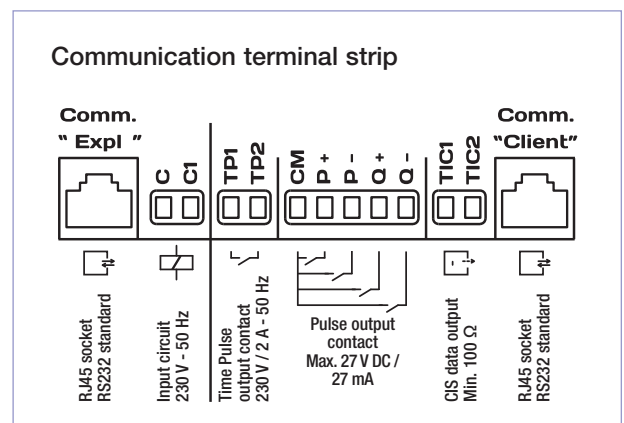

### Power terminal strip

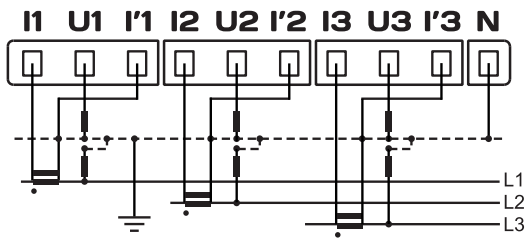

Terminals	Functions
I1	Phase 1 current input
U1	Phase 1 voltage input
I'1	Phase 1 current output
I2	Phase 2 current input
U2	Phase 2 voltage input
I'2	Phase 2 current output
I3	Phase 3 current input
U3	Phase 3 voltage input
I'3	Phase 3 current output
N	Neutral

### DIMENSIONS / MOUNTINGS

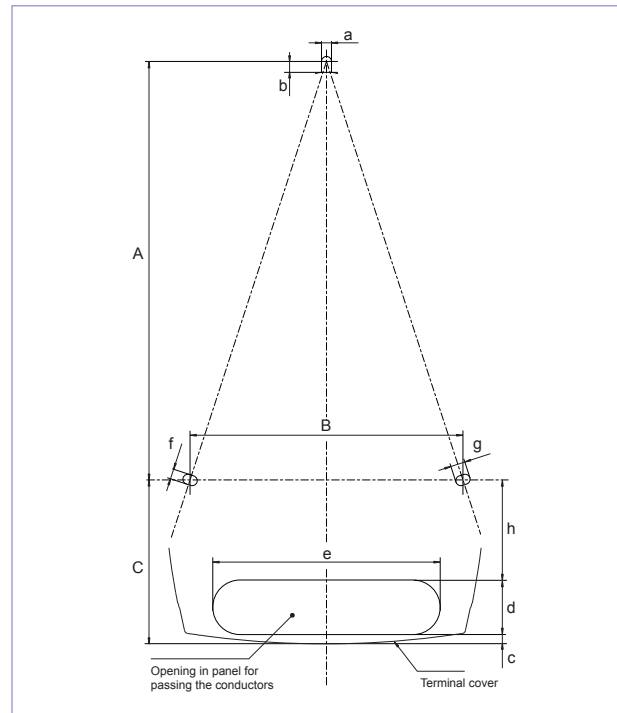
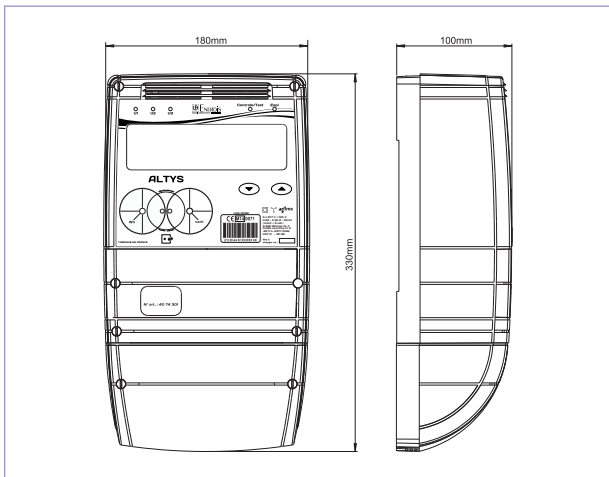

with (in mm):

$a = 5.5 \pm 0.1$

$b \geq 6$

$c \geq 5$

$d = 20 \pm 1$

$e = 125 \pm 1$

$f = 5.5 \pm 0.1$

$g = 8 \pm 0.1$

$h = 55 \pm 1$

$A = 230 \pm 1$

$B = 150 \pm 1$

$C = 90$

### TO ORDER

Model	Reference
ALTYs meter	P01331051

### ASSOCIATED PRODUCTS



Low voltage current measurement transformers for tariff metering



USB optical head  
P01330401

# MEMO RANGE

Power monitors for all types of electrical networks compliant with the IEC 61557-12 standard



## USER SECTORS



Tertiary



Industry



Energy efficiency



RS485 Modbus port: all the electrical measurements are transmitted in real time to the supervision system



4 tariffs: clear display of the current tariff



3 lines for easy-to-read display of the three-phase network



Total consumption displayed constantly

## DESCRIPTION

**MEMO P200** is a range of 2 simple, high-performance power monitors for immediately providing a clear view of your electrical grid.

- Measurement in all 4 quadrants
- Energy values: Ea, Eq, Es (import, export, cumulated, partial)
- Instantaneous values: V, U, I, THD-V, THD- I, F, crest factor, K factor, PF, P, Q, S
- Average max. values: I, P, Q, S
- Tariff metering: 4 tariffs with configurable tariff ranges (internal RTC clock)
- Relay outputs (on-off): Pulse mode, active energy or reactive energy (adjustable weight)



- Built-in Modbus RS485 communication
- Easy-to-read all-in-one screen
- Management of 4 tariffs
- Only 2 models to cover all your supervision needs

## ELECTRICAL SPECIFICATIONS

Voltage inputs	
Primary VT	100 V to 500 kV – Secondary VT: 100 V to 480 V
Measurement range	5...120 % $U_n$ - 50/60 Hz ( $U_n = 100/400$ V)
Overvoltage	120 % of 400 V (permanent) - 1 kV (0,5 s)
Consumption	< 0,25 VA – Input impedance: 1 M $\Omega$
Connection	3P3W - 3P4W - 1P2W
Current inputs (AC)	
Primary CT	1 A to 10,000 A – Secondary CT: 1 A to 5 A
Measurement range	1 % $I_n$ ...120 % $I_n$ ( $I_n = 5$ A)
Transient overload	120 A (0,5 s) – Permanent overload 6 A
Consumption	< 0,1 VA
Measurement accuracy	
Active power and energy	Class 0.5s (IEC 62053-22 & IEC 61557-12)
Reactive power and energy	Class 2 (IEC 62053-23 & IEC 61557-12)
Apparent power	1 % (IEC 61557-12)
Voltage / current	0.5 (IEC 61557-12)
Auxiliary power supply	
MEMO P200 ref. P01330825	85...275 VAC - 120...380VDC (< 2 W) - 50/60 Hz
MEMO P200 ref. P01330826	21...28 VDC (2 W)
RS485 output	
Protocol	Modbus RTU – Slave mode
Speed	2,400...38,400 bauds
On-off output	
Metering output	kWh / kVARh (IEC 62053-31)
Operating voltage	5...27 VDC
Max. current	27 mA

## GENERAL SPECIFICATIONS

Dimensions L x H x W	96 x 96 x 55 mm
Weight	350 g
Connection	Up to 4 mm <sup>2</sup> (measurement inputs) and 2.5 mm <sup>2</sup> (others)
Operating temperature	-25 °C to +55 °C (K55)
Altitude	Up to 2,000 m

## TO ORDER

Model	Reference
MEMO P200 - 230 VAC aux. power supply	P01330825
MEMO P200 - 24 VDC aux. power supply	P01330826
DIN rail mounting kit	P01330830

## ASSOCIATED PRODUCTS



Current transformers  
Cable primary, busbar primary, closed core or split core, etc.  
page 109

## DIMENSIONS (MM)

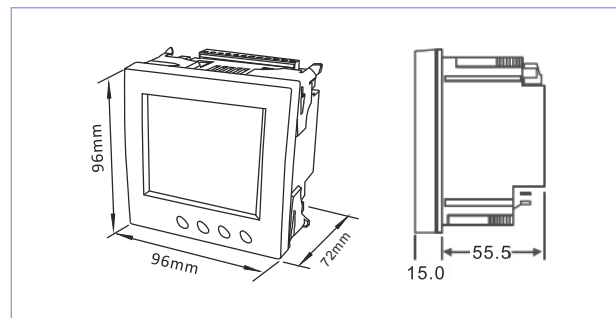

## ELECTRICAL CONNECTIONS

### SINGLE-PHASE

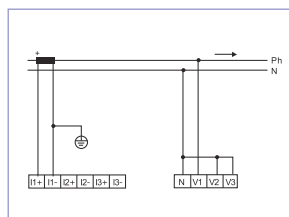

### Unbalanced three-phase, 4 wires - 3 CTs

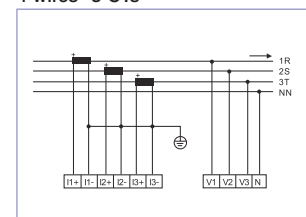

### Unbalanced three-phase, 3 wires - 3 CTs

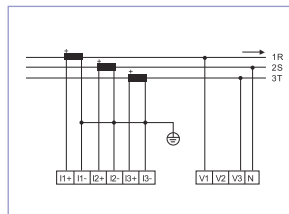

### Example of connection to VT

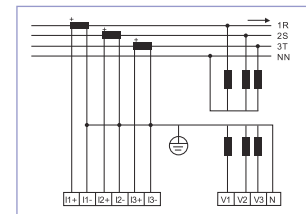

# ENERIUM RANGE

Power monitors ideal for the most critical MV/LV measurements in compliance with the IEC 61557-12 standard.



## DESCRIPTION

A complete range of 6 power monitors ideal for:

- LV/MV/HV network supervision
- installation sizing
- energy management
- electrical network quality applications

## SCREEN DISPLAYS



### DISPLAY

Real-time display of instantaneous, average values, etc. Time/date-stamped recording of min and max values.



### Recording

Indices and consumption curves (electricity, water, gas). Temperature curves and trend curves. Critical parameters.



### Harmonic analysis

Spectral analysis graph. THD measurement per phase on V, U, I and In. Up to 50th order.



### Graphics

For easier data analysis. Fresnel diagram. Gauge for V, U, I, P.



### Qualimetry

Log of events (dips, outages, overvoltages, overcurrents). Conformity graphs and statistics as per EN50160.



### Customizable screens

3 screens with 4 display lines each to organize the information as you wish.

## USER SECTORS



Industry



Energy generation



Energy transmission & distribution



Energy efficiency



Optical head for:

- programming
- reading the data
- upgrading the firmware



Ethernet output (Modbus/TCP)  
RS485 output (Modbus/Jbus RTU)

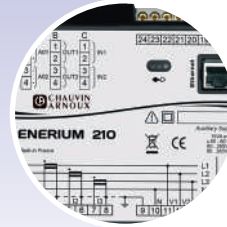

Screenless version for DIN-rail mounting or plate mounting

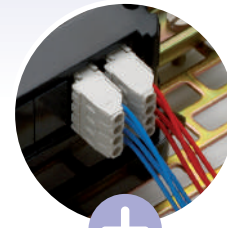

Up to 8 on-off or analog inputs/outputs



- 8 load curves
- 16 programmable alarms
- Graphics for easier data analysis
- Harmonic analysis up to the 50th order per phase on V, U, I and In
- Qualimetry according to EN50160 standard



### 16 alarms

Programmable, viewing of alarms log, recording of the last 64 events, flashing of display if alarm.



### Quick programming

Current transformer ratios and communication parameters can be set on the front panel or remotely.



### Indication of connection errors at start-up



### Preventive maintenance

Installation operating time.  
Operating time of monitored equipment.

## Power monitors

### Flush-mounting 96 x 96

### Flush-mounting 144 x 144



**Enerium 50**

**Enerium 150**

**Enerium 100**

**Enerium 200**

**Enerium 300**

#### ELECTRICAL ENERGY

#### MULTI-ENERGY

#### POWER QUALITY

**321**

**332**

**232**

**332**

**333**

#### Functional specifications

Accuracy class (IEC61557-12)	0.5	0.5	0.5	0.5 ou 0.2	0.2
Format	96 x 96 mm	96 x 96 mm	144 x 144 mm	144 x 144 mm	144 x 144 mm
Backlit LCD screen	■	■	■	■	■
Version without display			Enerium 110	Enerium 210	Enerium 310

Mounting	Flush-mounted, DIN rail* or plate-mounted*	Flush-mounted, DIN rail* or plate-mounted*	Flush-mounted, DIN rail* or plate-mounted* (Enerium 110)	Flush-mounted, DIN rail* or plate-mounted* (Enerium 210)	Flush-mounted, DIN rail* or plate-mounted* (Enerium 310)
----------	---	---	--	--	--

#### Harmonics

Max. order	25	50	25	50	50
------------	----	----	----	----	----

#### Recording functions

8 load curves	■	■		■	■
4 trend curves		■	■	■	■

#### Alarms

Number of alarms	16	16	16	16	16
Time/date-stamped events recorded	64	64	64	64	64

#### Qualimetry functions

Qualimetry according to EN50160					■
V, U, I and In waveform capture					16
Storage of last 1024 events (dips, outages, overvoltages) with time/date-stamping					■

#### Inputs / outputs

Max. number	2	2	8	8	8
-------------	---	---	---	---	---

#### Inputs (optional)

On-off (pulses or alarm)	0,1 or 2	0,1 or 2	0, 2, 4, 6 or 8	0, 2, 4, 6 or 8	0, 2, 4, 6 or 8
Analog					

#### Outputs (optional)

On-off (pulses or alarm)	0,1 or 2	0,1 or 2	0, 2, 4, 6 or 8	0, 2, 4, 6 or 8	0, 2, 4, 6 or 8
Analog	0 or 2	0 or 2	0,2 or 4	0,2 or 4	0,2 or 4

#### Graphics

Fresnel		■	■	■	■
Gauges		■			
Histograms of harmonic orders		■		■	■

#### Communication interface

Optical / USB	Front	Front	Front or rear	Front or rear	Front or rear
Ethernet or RS485	■	■	■	■	■
Metrological LED			■	■	■

#### Other functions

Programming on front panel	■	■	■	■	■
Programming via software	■	■	■	■	■

\* With mounting kit

METERS AND POWER MONITORS

NETWORK MONITORING FROM LV TO HV

CURRENT TRANSFORMERS AND SHUNTS

TRANSDUCERS

PANEL METERS AND SYNCHROCOUPLER

AUXILIARY RELAYS

CIVILIAN AND MILITARY NAVAL APPLICATIONS

SERVICES AND TRAINING

# EXAMPLE OF APPLICATIONS

## Analog inputs

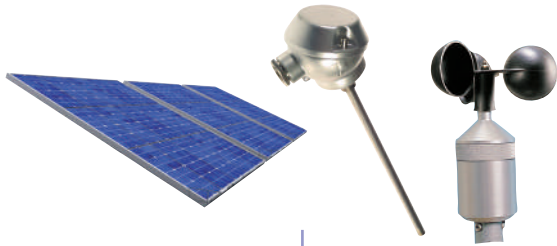

insolation, weather data, temperatures, etc.

## Metering inputs



water, gas, electricity

## Current and voltage inputs lv/mv/hv networks

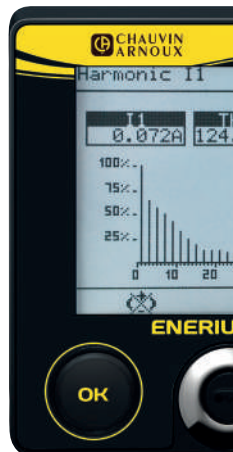

## Analog outputs



## Alarm relay outputs



### Synchro pulse inputs



### Storage of statuses and alarms

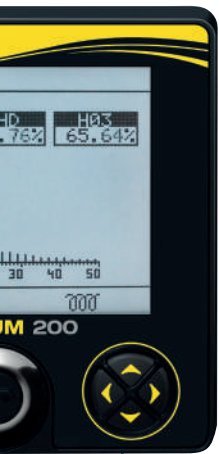

### Energy management software

### PLCs for CTM/TBM supervision



### PLC outputs (alarm/pulse)

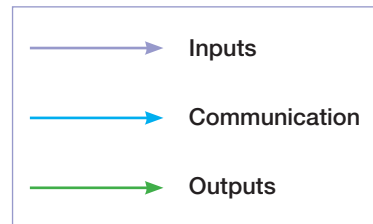

METERS AND POWER MONITORS  
NETWORK MONITORING FROM LV TO HV  
CURRENT TRANSFORMERS AND SHUNTS  
TRANSDUCERS  
PANEL METERS AND SYNCHROCOUPLER  
AUXILIARY RELAYS  
CIVILIAN AND MILITARY NAVAL APPLICATIONS  
SERVICES AND TRAINING

Photos: Chauvin Arnoux - Schneider Electric.

## MEASUREMENTS

	1 S	min	max	average	min average	max average
V, U	■	■	■	■		■
Vearth	■	■	■	■		■
I	■	■	■	■		■
In (calculated or measured) <sup>(1)</sup>	■	■	■	■	■	■
P (4 quadrants)	■	■	■	■		■
Pt (4 quadrants)	■	■	■	■		■
Q (4 quadrants)	■	■	■	■		■
Qt (4 quadrants)	■	■	■	■		■
S	■	■	■	■		■
St	■	■	■	■		■
PF (4 quadrants)	■	■	■	■		■
PFt (4 quadrants)	■	■	■	■	■	■
Cosφ (4 quadrants)	■	■	■	■		■
Cosφt (4 quadrants)	■	■	■	■	■	■
Tanφt (4 quadrants)	■	■	■	■	■	■
Frequency	■	■	■	■		■
V crest factor	■			■		■
I crest factor	■			■		■
U unbalance	■			■		■
Harmonics on V, U, I	■					
Harmonics on In	■					
THD V, U, I	■			■		■
THD In	■		■	■		■
Active energy (receiver, generator)	■					
Reactive energy (Qcad1, 2, 3, 4)	■					
Apparent energy (receiver, generator)	■					
On-off input (pulse mode)	■					
Analog input (Enerium 100/200)	■	■	■	■	■	■
Voltage presence hour meter (U)	■					
Load hour meter (I)	■					
Auxiliary power supply hour meter	■					

<sup>(1)</sup> On Enerium 30/50/150, calculated only

## CONNECTION DIAGRAMS

Single-phase

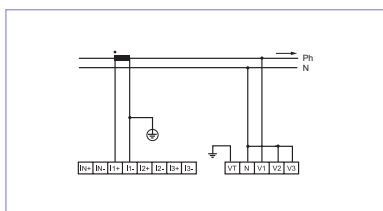

Balanced three-phase, 4 wires - 1 CT

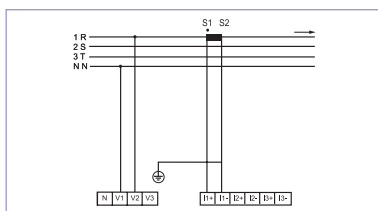

Unbalanced three-phase, 4 wires - 3 CTs

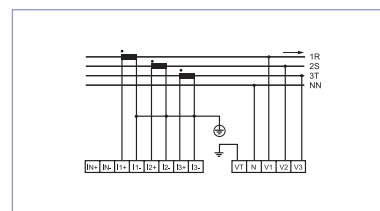

Unbalanced three-phase, 4 wires - 4 CTs  
Except Enerium 50/150

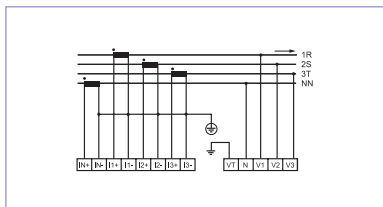

Unbalanced three-phase, 3 wires - 3 CTs

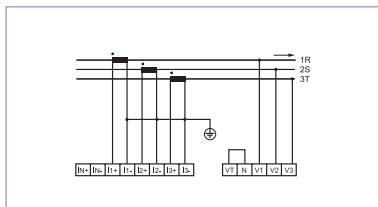

Unbalanced three-phase, 3 wires - 2 CTs

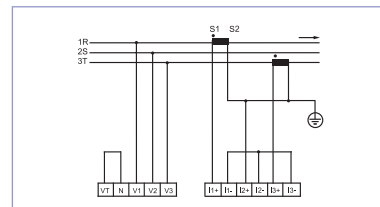

Example of connection to VT

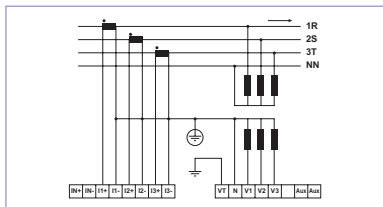

## TREND CURVES

(sauf Enerium 50)

1S VALUES	
V, Vearth	■
U12, U23, U31	■
I1, I2, I3, In	■
Pt	■
Qt	■
St	■
PFt	■
U unbalance	■
THD V, U, I, In	■
Analog inputs (Enerium 100/200/300 only)	■
AVERAGE VALUES	
V1, V2, V3	■
U12, U23, U31	■
I1, I2, I3, In	■
Gen: P1, P2, P3, Pt	■
Rec: P1, P2, P3, Pt	■
Analog inputs (Enerium 100/200 only)	■
Gen: PF1, PF2, PF3, PFt	■
Rec: PF1, PF2, PF3, PFt	■
Gen: Cosφ1, Cosφ2, Cosφ3, Cosφt	■
Rec: Cosφ1, Cosφ2, Cosφ3, Cosφt	■
Tanφt	■
Frequency	■
Crest factor V1, V2, V3	■
Crest factor I1, I2, I3	■
THD U12, U23, U31	■
THD I1, I2, I3, Ineutre	■
THD V1, V2, V3	■

## LOAD CURVES

(except on Enerium 100 and 110)

AVERAGE VALUES	
Pt Gen, Pt, Rec	■
Qcad1, Qcad2, Qcad3, Qcad4,	■
St Gen, St Rec	■
On-off input	■
Analog inputs (Enerium 200 only)	■

## ALARMS

1S VALUES	
V1, V2, V3	■
Vearth	■
U12, U23, U31	■
I1, I2, I3, In	■
Pt	■
Qt	■
St	■
PFt	■
Cosft	■
Tanft	■
Frequency	■
U unbalance	■
THD V, U, I, In	■
3 hour meters: network presence, on-load presence, aux. source	■
Analog inputs (Enerium 100/200 only)	■
AVERAGE VALUES	
Pt Gen, Pt Rec	■
Qt Gen, Qt Rec	■
St	■
Tanft (except on Enerium 50/150)	■
Tanft (except on Enerium 30/50/150)	■
Analog inputs (Enerium 100/200/300 only)	■

## ANALOG OUTPUTS (OPTION)

1S VALUES	
V1, V2, V3, Vearth	■
U12, U23, U31	■
I1, I2, I3, In	■
Pt	■
Q1, Q2, Q3	■
Qt	■
S1, S2, S3	■
St	■
PF1, PF2, PF3	■
PFt	■
Cosf1, Cosf2, Cosf3	■
Cosft	■
Tanft	■
Frequency	■

## SPECIFICATIONS

	ENERIUM 50/150 Class 0.5s	ENERIUM 100 Class 0.5s	ENERIUM 200 Class 0.2s	ENERIUM 300 Class 0.2s
<b>Electrical network</b>				
Max. phase-to-phase voltage measured	650 kV			
VT ratio	VT primary: 100 V to 650 kV VT secondary: 100 V to 480 V			
Max. current measured	25 000 A			
CT ratio	CT primary: 1 A to 25 000 A CT secondary: 1 A or 5 A			
Max. power measured	2 GW			
<b>Voltage inputs (AC)</b>				
Measurement range	5 to 130 % of Vn for Vn = 57.7 / 230 V (ph-N) 5 to 130 % of Un for Un = 100 / 400 V (ph-ph)			
Crest factor	2			
Measurement accuracy (U and V)	0.2 % of 20 % to 130 % of Un			
Overvoltage	Transient U = 800 V for 24 hours Permanent 130 % of 400 V = 520 V			
Frequency	50/60 Hz or 400 Hz	50/60 Hz	50/60 Hz	50/60 Hz
Consumption	< 0.15 VA		< 0.1 VA	
Input impedance	0.44 M $\Omega$		1 M $\Omega$	
<b>Current inputs (AC)</b>				
Measurement range	1 % to 130 % of In for In = 5 A			
Crest factor	3			
Measurement accuracy	0.2 % of $\geq 10$ %... $\leq 130$ % 0.5 % of $\geq 5$ %... $\leq 10$ % 1 % of $\geq 1$ % to $\leq 5$ %			
Acceptable overload	Transient I = 250 A for 1 second Permanent 130 % of 5 A = 6.5 A			
Consumption	< 0.15 VA			
<b>Compliance with standards</b>				
IEC 62053-21/22	Active energy Class 0.5s		Active energy Class 0.2s	Active energy Class 0.2s
IEC 62053-23/24	Reactive energy Class 0.5s			
IEC 61557-12	V,I Class 0.2 P,S Class 0.5	Class 0.5	Class 0.2	Class 0.2
PMD SD/SS	Active energy Class 0.5 Reactive energy Class 0.5		Active energy Class 0.2 Reactive energy Class 0.5	Active energy Class 0.2 Reactive energy Class 0.2
<b>Multi-measurement (accuracies)</b>				
Active power and energy	0.5 % for 5 % In $\leq$ I $\leq$ Imax		0.2 % for 5 % In $\leq$ I $\leq$ Imax	
Reactive power and energy	0.5 % for 5 % In $\leq$ I $\leq$ Imax			
Apparent power and energy	0.5 % for 5 % In $\leq$ I $\leq$ Imax			
Power Factor PF and cos $\phi$	$\pm 0.02$ counts when 0.5 inductive < PF < 0.5 capacitive $\pm 0.05$ counts when 0.2 inductive < PF < 0.2 capacitive			
Frequency	$\pm 0,1$ % of 42.5 to 69 Hz			
Sampling frequency	6.4 kHz to 50 Hz			
THD-I, THD-V and THD-U	$\pm 0.5$ counts			
Harmonics order by order	$\pm 0.5$ counts			

	ENERIUM 50/150 Class 0.5s	ENERIUM 100/200 Class 0.5s	ENERIUM 200 Class 0.2s	ENERIUM 300 Class 0.2s
<b>RS485 output</b>				
Connection	2 wires, half duplex			
Protocol	ModBus / JBus mode RTU			
Speed (configurable)	2 400 - 4 800 - 9 600 - 19 200 - 34 800 (115 200 for ENERIUM 50/150)			
Parity	Even, odd or none			
JBus addresses	1 to 247			
<b>Ethernet output</b>				
Type	RJ45 - 8 points			
Protocole	ModBus/TCP			
Speed (configurable)	Compatible with 10, 100 and 1,000 base T			
<b>Auxiliary power supply</b>				
Power supply	80 to 265 Vac (< 15 VA) 42.5 to 69 Hz 80 to 265Vdc 19 to 57 Vdc (<7.5 W)		80 to 265 Vac (< 20 VA) 42.5 to 69 Hz 80 to 265Vdc 19 to 57 Vdc (< 10 W)	
<b>Digital inputs (on-off or metering pulse)</b>				
Operating voltage	Up to 70 Vdc max		High level: 10 to 110 Vdc Low level: 0 to 5 Vdc	
Min. signal width			High level: 30 ms Low level: 30 ms	
Consumption			< 0,5 W	
<b>Pulse or alarm relay outputs</b>				
Type	Static relay			
Operating voltage	24 to 110 Vdc $\pm$ 20 % 24 to 230 Vac $\pm$ 10 %			
Current max.	100 mA			
Compliance with standard	IEC 62053-31			
<b>Analog inputs</b>				
Scale	Configurable from -20 and +20 mA			
Power consumption	< 50 mW			
Input impedance	50 $\Omega$			
<b>Analog outputs</b>				
Scale	Configurable between -20 and +20 mA			
Acceptable overload	500 $\Omega$			
Response time	< 500 ms			
<b>Storage</b>				
Non-volatile memory	Configuration parameters – Recordings (curves, alarms, min-max, qualimetry events log, EN50160 statistics)			
RAM	Capture of waveforms			
<b>Environmental specifications</b>				
Operating temperature	-10 °C to +55 °C (K55 as per IEC 61557-12)			
Operating humidity	95 % to 40 °C			
Storage temperature	-25 °C to +70 °C			
<b>Safety specifications</b>				
Pollution	2			
Behavior in fire	UL94, severity V1			
Installation category	3			

METERS AND  
POWER MONITORSNETWORK MONITORING  
FROM LV TO HVCURRENT TRANSFORMERS  
AND SHUNTS

TRANSDUCERS

PANEL METERS AND  
SYNCHROCOUPLER

AUXILIARY RELAYS

CIVILIAN AND MILITARY NAVAL  
APPLICATIONS

SERVICES AND TRAINING

## ACCESSORIES

Kit for DIN-rail or plate mounting

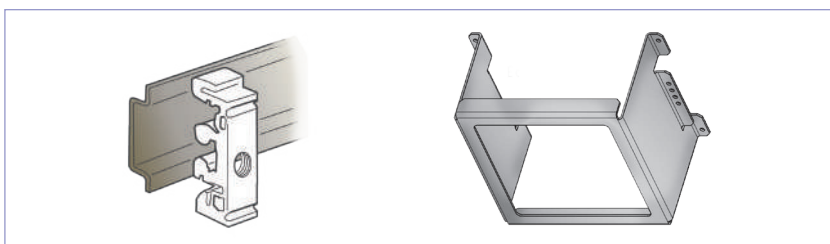

## DIMENSIONS (MM)

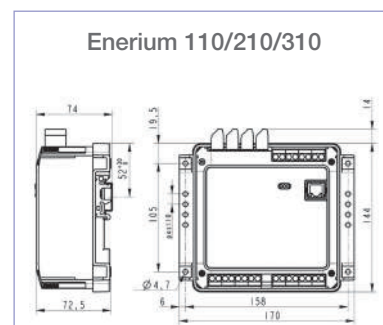
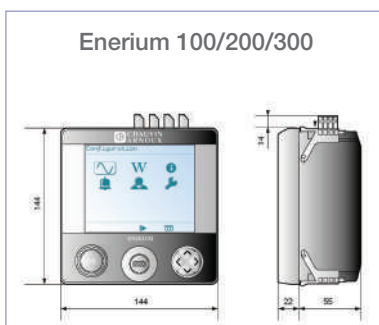
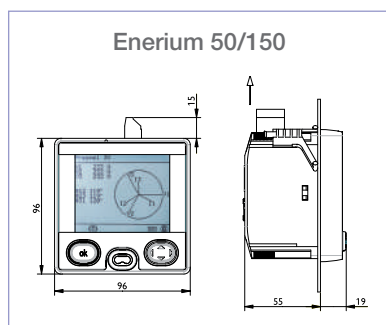

## TO ORDER

## STANDARD PRODUCTS

Model	Frequency	Accuracy class	Power supply	Communication	On-Off inputs	On-Off Outputs	Analog outputs	Reference	IM
<b>Enerium 50</b>	50 / 60 HZ	0.5s	80 to 265 Vac / 80 to 265Vdc	RS485	0	0	0	P01330805	321
	50 / 60 HZ	0.5s	80 to 265 Vac / 80 to 265Vdc	Ethernet	0	0	0	P01330806	321
	50 / 60 HZ	0.5s	80 to 265 Vac / 80 to 265Vdc	RS485	1	1	0	P01330807	321
	50 / 60 HZ	0.5s	80 to 265 Vac / 80 to 265Vdc	Ethernet	1	1	0	P01330808	321
<b>Enerium 150</b>	50 / 60 HZ	0.5s	80 to 265 Vac / 80 to 265Vdc	RS485	0	0	0	P01330809	332
	50 / 60 HZ	0.5s	80 to 265 Vac / 80 to 265Vdc	Ethernet	0	0	0	P01330810	332
	50 / 60 HZ	0.5s	80 to 265 Vac / 80 to 265Vdc	RS485	0	2	0	P01330811	332
	50 / 60 HZ	0.5s	80 to 265 Vac / 80 to 265Vdc	Ethernet	0	2	0	P01330812	332
<b>Enerium 100</b>	50 / 60 HZ	0.5s	80 to 265 Vac / 80 to 265Vdc	RS485	0	0	0	P01330831	232
	50 / 60 HZ	0.5s	80 to 265 Vac / 80 to 265Vdc	RS485	2	2	0	P01330832	232
<b>Enerium 200</b>	50 / 60 HZ	0.5s	80 to 265 Vac / 80 to 265Vdc	RS485	4	2	0	P01330833	332
	50 / 60 HZ	0.5s	80 to 265 Vac / 80 to 265Vdc	Ethernet	2	2	2	P01330834	332
<b>Enerium 210</b>	50 / 60 HZ	0.5s	80 to 265 Vac / 80 to 265Vdc	Ethernet	8	0	0	P01330835	332
<b>Enerium 300</b>	50 / 60 HZ	0.2s	80 to 265 Vac / 80 to 265Vdc	RS485	0	0	0	P01330816	333
	50 / 60 HZ	0.2s	80 to 265 Vac / 80 to 265Vdc	Ethernet	0	0	0	P01330817	333
	50 / 60 HZ	0.2s	19 to 58 Vdc	RS485	0	0	0	P01330818	333
	50 / 60 HZ	0.2s	19 to 58 Vdc	Ethernet	0	0	0	P01330819	333

## ACCESSORIES

Model	Reference
<b>Optical head for ENERIUM 50/150</b>	P01330403
<b>Optical head for ENERIUM 100/110 - 200/210 - 300/310</b>	P01330401
<b>DIN-rail mounting kit for ENERIUM 30/50/150</b>	P01330830
<b>DIN-rail mounting kit for ENERIUM 100/200/300</b>	P01330360
<b>Power supply for On-Off inputs 85 to 256 Vac/12 Vdc - 3.5 A (42 W)</b>	ACCJ1004

## CONFIGURED PRODUCTS

## ENERIUM 1 2 3 4 5 6 7 8 9

### 1 - Model

<b>50</b>	ENERIUM 50 - Electrical energy - Load curves - Format 96 x 96
<b>150</b>	ENERIUM 50 + Trend curves - Format 96 x 96
<b>100</b>	ENERIUM 100 - Multi-énergies - Courbes d'enregistrement Format 144 x 144
<b>110</b>	ENERIUM 100 screenless version - Format 144 x 144
<b>200</b>	ENERIUM 100 + Load curves - Format 144 x 144
<b>210</b>	ENERIUM 200 screenless version - Format 144 x 144
<b>300</b>	ENERIUM 200 + Qualimetry
<b>310</b>	ENERIUM 300 screenless version

### 2 - Frequency of network measured

<b>0</b>	50 / 60 Hz
<b>1</b>	400 Hz (except on Enerium 100 / 200 class 0.5s / 300)

### 3 - Auxiliary power supply

<b>0</b>	80 to 265 Vac / 80 to 265Vdc
<b>1</b>	19.2 to 58 Vdc

### 4 - Communication

<b>0</b>	RS485
<b>1</b>	Ethernet

Note : with choices 5, 6, 7 and 8, it is possible to have a maximum of 8 inputs and/or outputs (ENERIUM 100-110/200-210). Note: for the Enerium 50/150, choices 5 and 6 only allow the following combinations: 0-0, 1-1, 2-0, 0-2.

### 5 - Metering (or On-Off) inputs

<b>0</b>	none
<b>1</b>	1 input (only on ENERIUM 50 / 150)
<b>2</b>	2 inputs
<b>4</b>	4 inputs (except on ENERIUM 50 / 150)
<b>6</b>	6 inputs (except on ENERIUM 50 / 150)
<b>8</b>	8 inputs (except on ENERIUM 50 / 150)

### 6 - On-Off outputs

<b>0</b>	none
<b>1</b>	1 output (only on ENERIUM 30 / 50 / 150)
<b>2</b>	2 outputs
<b>4</b>	4 outputs ( except on ENERIUM 30 / 50 / 150 )
<b>6</b>	6 outputs ( except on ENERIUM 30 / 50 / 150 )
<b>8</b>	8 outputs ( except on ENERIUM 30 / 50 / 150 )

### 7 - Analog inputs (ENERIUM 100/200/300 only)

<b>0</b>	none
<b>2</b>	2 analog inputs
<b>4</b>	4 analog inputs
<b>6</b>	6 analog inputs
<b>8</b>	8 analog inputs

### 8 - Analog outputs

<b>0</b>	none
<b>2</b>	2 outputs
<b>4</b>	4 outputs (except on Enerium 50 / 150)

### 9 - Accuracy class

<b>5</b>	0.5s (except on ENERIUM 300)
<b>2</b>	0.2s (ENERIUM 200/210/300/310 only)

**Example:** Enerium 200, frequency 50/60 Hz, 80 to 264 Vac auxiliary power supply, RS485 communication, 2 on-off inputs, no on-off outputs, no analog inputs, no analog outputs, Class 0.2s

> order ENERIUM 200 01020002 :

<b>1</b>	<b>200</b>	<b>2</b>	<b>0</b>	<b>3</b>	<b>0</b>	<b>4</b>	<b>0</b>	<b>5</b>	<b>2</b>	<b>6</b>	<b>0</b>	<b>7</b>	<b>0</b>
<b>8</b>	<b>0</b>	<b>9</b>	<b>2</b>										

## ASSOCIATED PRODUCTS



Current transformers  
Cable primary, busbar primary, closed core or split core, etc.  
Page 109

METERS AND  
POWER MONITORS

NETWORK MONITORING  
FROM LV TO HV

CURRENT TRANSFORMERS  
AND SHUNTS

TRANSDUCEURS

PANEL METERS AND  
SYNCHROCOUPLER

AUXILIARY RELAYS

CIVILIAN AND MILITARY NAVAL  
APPLICATIONS

SERVICES AND TRAINING

# E.VIEW

Configuration, installation diagnostics and display software for the ENERIUM range of power monitors.

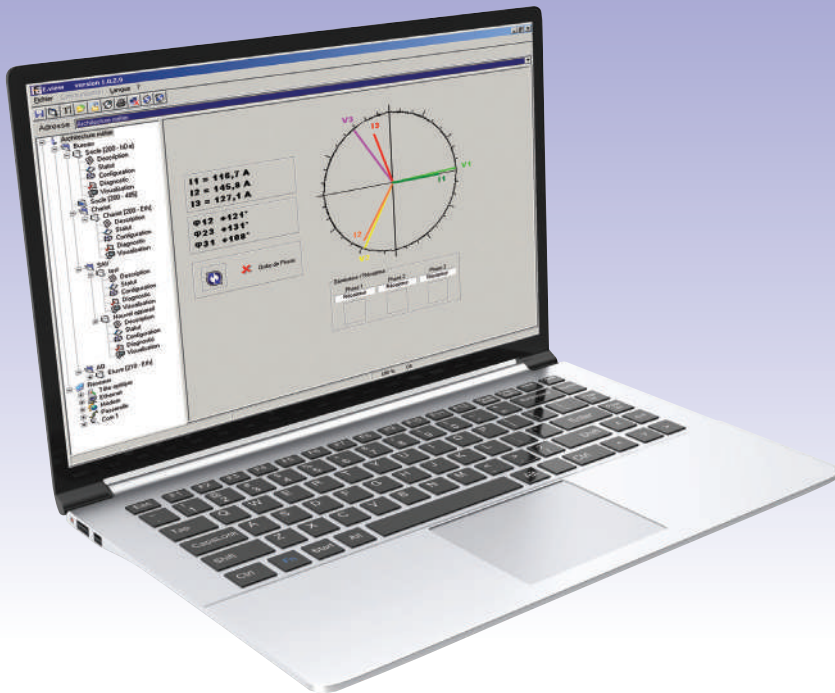

## DESCRIPTION

**E.View** software can be used to configure the power monitors in the ENERIUM range remotely via the RS485 network, Ethernet network or optical head. At any time, it is possible to program the communication parameters of the products (address, speed, parity, etc.) and the configuration parameters (CT ratio, PT ratio, alarm thresholds, etc.).

**E.View** can be used for remote control of the inputs and outputs on ENERIUM power monitors. E.View enables you to view the basic electrical parameters and retrieve recordings of the load curves, trend curves and alarms log in .txt format.

## USER SECTORS



Industry



Energy generation



Energy transmission & distribution



Energy efficiency



- Configuration of the whole range of ENERIUM power monitors
- Installation diagnostics
- Display of the electrical parameters
- Copies of recordings in.txt format

Functions	E.view
Description	■
Status	■
Configuration	■
Diagnostics	■
Display	■

## E.VIEW

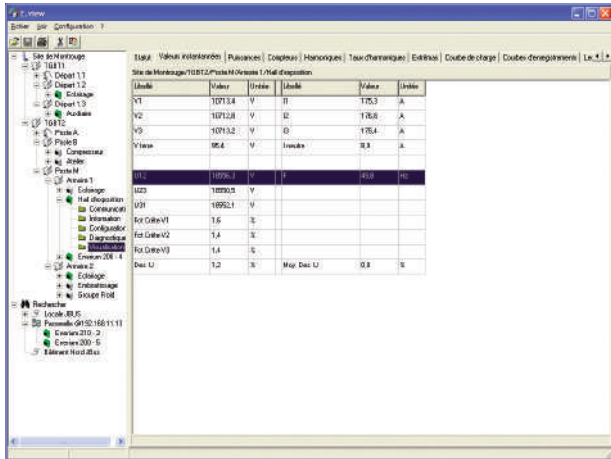

## DESCRIPTION

- The tabs enable you to define the hardware status of the Enerium and the functional use of the inputs (on-off) and outputs (analog or on-off)
- Details of slots: analog output board, on-off I/O board
- Communication (Ethernet, RS485)

## CONFIGURATION OF ENERIUM POWER MONITORS

- Configuration of the communication parameters
- Modification of the date and time
- Configuration of the CTs, PT, alarm status, overrun thresholds, etc.
- Configuration and activation of alarms
- Programming of the analog outputs
- Programming of the inputs/outputs
- Reinitialization of the meters, overruns, log, etc.

## ASSOCIATED PRODUCTS



### ENERIUM

Power monitors for all electrical networks compliant with the IEC 61557-12 standard.  
page 64



### ENERIUM

Optical head  
page 64

## NETWORKING ASSISTANCE

- Communication test on a power monitor of your choice among all the power monitors on the RS485 or Ethernet network
- Automatic detection of all the products on the RS485 or Ethernet networks with display of the communication parameters (address, speed, parity, stop bit) and the type of configuration (CT and PT ratios) for each power monitor.

## STATUS

This page can only be used to view the Enerium's status (voltage and current inputs, phase order, time synchro, elementary alarms, global alarms, pulse and analog outputs).

- Operation (correct or incorrect) of the voltage, current and phase order quantities
- Status of global alarms
- Status of elementary alarms
- Status of pulse outputs and analog outputs

## BACKUP AND LOADING OF CONFIGURATIONS

- Recording and import of a configuration
- Downloading of the configuration from one power monitor to another via PC
- Writing of the new configuration
- Self-diagnosis of the configuration

## SCREEN PROGRAMMING

- Programming of the 3 customizable screens

## COMMUNICATION

- Ethernet
- RS485/RS232
- Modem
- Optical head (infrared)

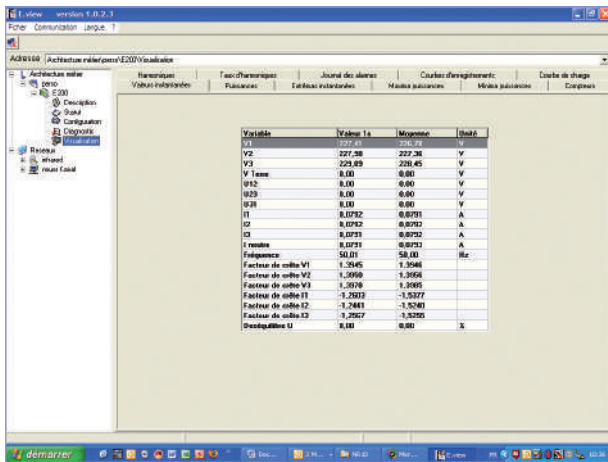

Variable	Valeur 1s	Moyenne	Unité
V1	227.38	227.38	V
V2	227.38	227.38	V
V3	229.89	228.45	V
V1 Taux	0.00	0.00	V
V12	0.00	0.00	V
V23	0.00	0.00	V
V31	0.00	0.00	V
I1	0.0782	0.0751	A
I2	0.0782	0.0750	A
I3	0.0751	0.0750	A
Imax	0.0751	0.0751	A
Fréquence	50.00	50.00	Hz
Facteur de puissance V1	1.5545	1.5548	
Facteur de puissance V2	1.5550	1.5554	
Facteur de puissance V3	1.5518	1.5565	
Facteur de puissance I1	-1.2512	-1.5277	
Facteur de puissance I2	-1.2481	-1.5240	
Facteur de puissance I3	-1.2527	-1.5255	
Residualité U	0.00	0.00	%

## DISPLAY OF THE BASIC PARAMETERS

- Supervision of the electrical network by displaying the essential parameters measured by ENERIUM
- Consultation of the instantaneous and average values of the electrical quantities required to operate the electrical network
- Examples of display possibilities
  - Instantaneous values
  - Instantaneous extreme values
  - Maximum/minimum power values - Energy meters
  - Maximum odd harmonic values per order - Total harmonic distortion (THD)
  - Alarm log
  - Trend curves
  - Load curves

## REMOTE CONTROL OF THE INPUTS/OUTPUTS

All the inputs and outputs can be controlled remotely and separately. This function can be used, for example, to simulate an analog output in order to verify the integration of an ENERIUM power monitor in the process.

## RETRIEVAL OF THE RECORDS IN .TXT FORMAT

- Load curves
- Trend curves
- Alarm log

## ASSOCIATED PRODUCTS



**ENERIUM**  
Power monitors for all electrical networks compliant with the IEC 61557-12 standard.  
page 64



**ENERIUM**  
Optical head  
page 64

## DIAGNOSIS OF THE INSTALLATION

This page can be used to read the digital inputs, as well as to read and/or force the digital and analog outputs of ENERIUM.

- This concerns:
  - Pulse inputs
  - On-off inputs
  - On-off outputs - Analog outputs
- Detection of phase order reversal
  - Presence of voltage
  - Presence of current
  - Status of the current ratings being used by the power monitor - Indication of the generator/receiver mode of phases 1, 2 and 3
- Status of the alarms
- Status of the alarm relays
- Detection of external time synchronization errors
- Malfunction of an option card
- Saturation and possible loss of a pulse on the on-off outputs
- Trend curve memory occupancy
- Load curve memory occupancy

The E.VIEW software can be **DOWNLOADED FREE OF CHARGE** from the support section of [www.chauvin-arnoux-energy.com](http://www.chauvin-arnoux-energy.com)





**NETWORK SUPERVISION AND PHYSICAL MEASUREMENT**

# **NETWORK MONITORING FROM LOW VOLTAGE TO HIGH VOLTAGE**



METERS AND  
POWER MONITORS

NETWORK MONITORING  
FROM LV TO HV

CURRENT TRANSFORMERS  
AND SHUNTS

TRANSDUCERS

PANEL METERS AND  
SYNCHROCOUPLER

AUXILIARY RELAYS

CIVILIAN AND MILITARY  
NAVAL APPLICATIONS

SERVICES AND TRAINING

- 80 NETWORK ANALYZERS
- 98 MONITORING OF LOW-VOLTAGE NETWORKS

# NETWORK ANALYZERS

## ELECTRICAL NETWORK ANALYZERS

### PERMANENT ANALYZERS - MAP RANGE - CLASS A



**MAP 607**  
Single-phase voltage  
quality analyzer  
page 87



**MAP Compact**  
Three-phase voltage/current power and  
network quality analyzer + Monitoring of  
EN50160 template  
page 88

### POWER QUALITY MONITOR



**ENERIUM 300**  
Power monitor  
Qualimetry according to EN50160  
page 65

## USER SECTORS



Tertiary



Industry



Energy  
generation



Energy  
transmission  
& distribution



Energy  
efficiency



Navy

## MANAGEMENT AND ANALYSIS SOFTWARE

### MANAGEMENT AND ANALYSIS SOFTWARE



#### Qual-SRT

Configuration and  
display  
page 88



#### Qual-View

Settings, display and  
analysis  
page 88

### FOR MAP COMPACT



#### Qual-SRTc

Settings and  
display  
page 88



#### Qual-View

Settings, display  
and analysis  
page 88

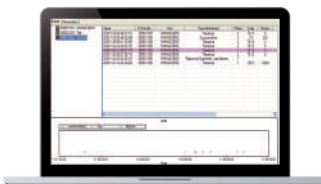

#### E.Qual-Premium Server

Settings, remote data retrieval,  
display, administration and  
analysis  
page 88

METERS AND  
POWER MONITORS

NETWORK MONITORING  
FROM LV TO HV

CURRENT TRANSFORMERS  
AND SHUNTS

TRANSDUCERS

PANEL METERS AND  
SYNCHROCOUPLER

AUXILIARY RELAYS

CIVILIAN AND MILITARY  
NAVAL APPLICATIONS

SERVICES AND TRAINING

# INFO & ADVICE

## COVER ALL YOUR REQUIREMENTS FOR ENERGY QUALITY SUPERVISION AND ARBITRATION

### UNDERSTANDING THE DETAILS OF YOUR ELECTRICITY BIL

It is essential to keep a close eye on your real energy consumption for energy monitoring because, when considerable power is involved, the electricity bill is also high. So measuring these high power values with mediocre accuracy means that uncertainty persists concerning actual energy consumption and the related cost.

This is why we recommend choosing measuring equipment with 0.2% accuracy, currently the highest accuracy standardized by the IEC 62053-22 international standard on metering active energy.

**Electrical environments** may also be **disturbed** (presence of harmonics, phase shift on the current and voltage, etc.), thus causing deterioration of the power factor. Energy measurement in these conditions is more complex. For such environments, **the accuracy of your equipment should be accompanied by the letter "s"**, guaranteeing that you have the most reliable energy measurement possible in disturbed environments.

If you choose 0.2s accuracy on your power monitor, it guarantees that you meter energy with the same accuracy as your tariff meter (or higher).

### Estimate the impact of complex electricity consumption on your network to take quick action.

Electricity differs from the other utilities (gas, water, etc.) due to the complexity of its composition and the wide variety of indicators which help to optimize its cost. **The apparent power is the most important thing to monitor** because it will determine the quantity of electrical energy and thus the subscription which you will need. To achieve savings, you therefore have to take into account the two components of the apparent energy which need to be reduced:

- **Reactive energy:**

The inductive loads on the network will create a mismatch between the current and voltage which naturally draws unwanted power. The rejection of this "reactive" power is limited to a certain proportion of the active power by the network administrators. This limitation may be performed by adding "compensation" solutions at the level of the load or at certain points in the network.

- **Distorting power:**

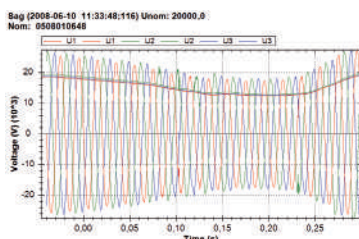

Distorting loads on the electrical network change the waveforms of the currents and voltages by producing signals whose frequencies are different from the rated frequency of the network. These signals, called harmonics, will have a large number of harmful effects, such as changing the voltage level of the network, drawing additional "distorting" power and increasing the currents in certain conductors. The harmonics, whose presence is also limited by the standard, can be corrected by filtering systems.

### UNDERSTANDING ENERGY QUALITY AND HOW TO IMPROVE IT

You must **anticipate the losses and maintenance costs on the equipment** due to poor energy quality. The variations of the main electrical quantities outside the tolerance ranges shorten the life span of the electronic equipment in the network. Constant monitoring of these quantities will enable you to establish a correlation between equipment maintenance and network energy quality. Energy quality events such as dips, outages and voltage surges are bad for the operating continuity of electrical installations. The costs linked to production losses and production downtime after voltage dips may be high. **Recording to quantify and qualify the energy quality events will subsequently help to find the sources of the anomaly so that you can correct them.** Sector-specific templates are available to qualify the dips in terms of their harmful effects on specific equipment:

- The **ITIC template** for qualifying a dip which may corrupt data or damage computer bays
- The **SEMIF47 template** for qualifying a dip which may cause a fault in sensitive production-line tooling (such as semi-conductor production sites)

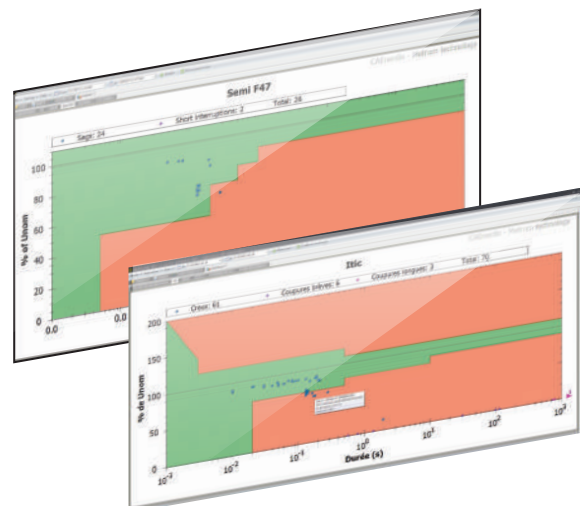

## MONITORING THE COMMITMENTS CONCERNING THE ELECTRICITY SUPPLY

The **European standard** concerning energy supply quality is the **EN50160** standard. This describes the requirements covering the voltage and frequency at any point of connection.

All electricity suppliers must comply with this standard. By using an analyzer, you can check all the parameters and produce a compliance or non-compliance report.



Specific commitments may be agreed between the electricity suppliers and customers, limiting the annual number of outages or voltage dips. The use of an **analyzer** will enable the supplier to **confirm to customers that these commitments are met**, while also allowing the customer to contest fulfilment of the commitments if quality events occur.

To provide indisputable information on energy quality (events or electrical quantities), the measurement must be reproducible. The IEC 61000-4-30 standard specifies the methods for measuring the events and electrical quantities and also defines several Classes, of which Class A is the most demanding.

This helps to guarantee that two different items of equipment connected to the same location will give identical results.

**Class A is the crucial criterion for choosing a network analyzer**

## CHOOSING YOUR EQUIPMENT

A simple, economical solution for supervising energy quality

### ENERIUM 300

page 65

Assess the impact of energy quality on your electrical feeder

The power monitor focused on energy quality

- Accuracy class 0.2s
- Storage of consumption data
- Recording of trend curves
- Harmonic analysis
- Events log (dips, outages, etc.)
- Monitoring of compliance with the EN50160 standard
- Capture of waveforms
- Up to 8 input/outputs



Switch to a higher gear with the MAP network analyzers

- Class A IEC 61000-4-30
- Capture of the most complex energy quality parameters
- Continuous data storage 24/7
- Production of turnkey reports and investigative tools using a wide range of software products

### MAP Compact

page 88

Monitor your electrical network simply and effectively

- A compact format for easier integration
- A screen for the basic information
- Access to the data locally via USB or remotely via Ethernet
- 3-channel voltage input, 230/400 VRMS
- 4-channel current input, 0 – 6 A RMS
- Auxiliary power supply: 175 – 255 Vac (10 s power reserve)
- 2 On-Off inputs/outputs



## Power supply faults and deteriorating electrical power quality cause disturbances which adversely affect the operation of electro-technical equipment.

### WHAT ARE THE DISTURBANCES INVOLVED? WHAT ARE THEIR CAUSES AND CONSEQUENCES?

#### SLOW VARIATIONS AND INTERRUPTIONS

The amplitude of the voltage is usually the primary contractual commitment given by the power distributor. It is nevertheless subject to abnormal variations which may reach a level close to 0.

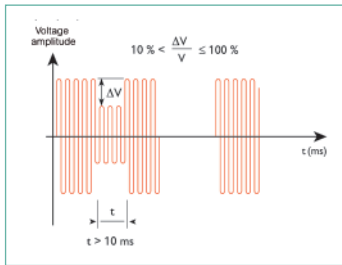

The nominal range of variation of the network voltage is set by the power distributor at  $\pm 10\%$  of the phase-to-phase voltage.

<b>Faults generated</b>	<ul style="list-style-type: none"> <li>• Voltage surge or dip</li> <li>• Micro-interruptions &lt; 10 ms</li> <li>• Short interruptions &lt; 3 min and long interruptions &gt; 3 min</li> </ul>
<b>Causes linked to disturbances due to equipments</b>	<ul style="list-style-type: none"> <li>• Heavy loads connected to a network whose short-circuit power at a delivery point is undersized</li> <li>• High-power motors, transformers and capacitor banks</li> <li>• Internal faults in the electrical installation</li> </ul>
<b>Causes linked to electrical power supply networks</b>	<ul style="list-style-type: none"> <li>• Atmospheric phenomena and accidental short-circuits</li> <li>• Transmission and distribution network management problems</li> </ul>
<b>Parameters to be measured</b>	<ul style="list-style-type: none"> <li>• Amplitude and duration of the variation</li> </ul>

#### RAPID VARIATIONS

Digital analyzers with a high sampling frequency are necessary to measure transient overvoltages.

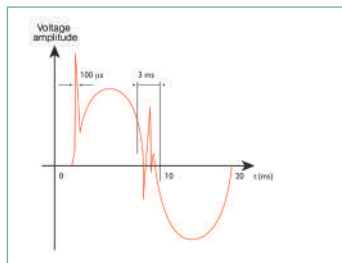

<b>Faults generated</b>	<ul style="list-style-type: none"> <li>• Transient overvoltages (&lt;10 ms)</li> </ul>
<b>Causes linked to disturbances due to equipments</b>	<ul style="list-style-type: none"> <li>• Switching of more or less inductive loads causing transient overvoltages at high frequency</li> <li>• Switching of 2 thyristors causing a very brief short-circuit between the 2 phases</li> </ul>
<b>Causes linked to electrical power supply networks</b>	<ul style="list-style-type: none"> <li>• Atmospheric phenomena (lightning)</li> </ul>
<b>Parameters to be measured</b>	<ul style="list-style-type: none"> <li>• Maximum amplitude and duration of the transient</li> </ul>

#### RAPID VOLTAGE VARIATIONS (FLICKER)

The discomfort caused by rapid variations in the brightness of lighting is measured by the flicker value. Effects on people: headache, irritability, epileptic fit, etc.

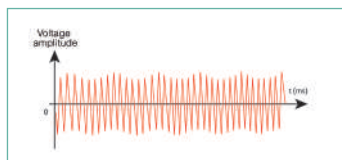

<b>Faults generated</b>	<ul style="list-style-type: none"> <li>• Variation of brightness</li> <li>• Flickering of computer screens</li> </ul>
<b>Causes linked to disturbances due to equipments</b>	<ul style="list-style-type: none"> <li>• Arc furnaces</li> <li>• Laser printers</li> <li>• Air-conditioning systems</li> </ul>
<b>Causes linked to electrical power supply networks</b>	<ul style="list-style-type: none"> <li>• None</li> </ul>
<b>Parameters to be measured</b>	<ul style="list-style-type: none"> <li>• Short-term flicker (Pst) and long-term flicker (Plt)</li> </ul>

## VOLTAGE UNBALANCE

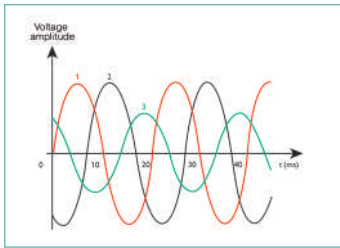

<b>Faults generated</b>	<ul style="list-style-type: none"> <li>• Current or voltage not phase-shifted by 120° and with different amplitudes</li> </ul>
<b>Causes linked to disturbances due to equipments</b>	<ul style="list-style-type: none"> <li>• Load absorbing power in an unbalanced way on the 3 phases</li> <li>• Disconnection of one electrical power supply phase</li> </ul>
<b>Causes linked to electrical power supply networks</b>	<ul style="list-style-type: none"> <li>• Disconnection of one electrical power supply phase</li> </ul>
<b>Parameters to be measured</b>	<ul style="list-style-type: none"> <li>• Level of unbalance, direct, inverse and homopolar voltage or current</li> </ul>

## HARMONICS AND INTERHARMONICS

The current consumed by the loads no longer has a pure sinusoidal waveform. The current distortion implies a voltage distortion that also depends on the impedance of the source.

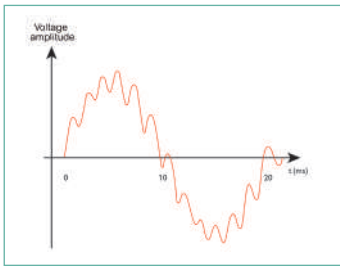

**Harmonics:** sinusoidal waves whose frequencies are multiples of 50 Hz superimposed on the fundamental wave. **Interharmonics:** component of the signal superimposed on the fundamental wave (50 Hz) but which is not a multiple of the fundamental (e.g. 175 Hz).

<b>Faults generated</b>	<ul style="list-style-type: none"> <li>• Functional synchronization problems, switching</li> <li>• Untimely tripping of circuit-breakers</li> <li>• Induced heating reducing the life span of rotating machines, capacitors, power transformers and neutral conductors</li> </ul>
<b>Causes linked to disturbances due to equipments</b>	<ul style="list-style-type: none"> <li>• EQUIPMENT containing power electronics: variable speed drives, uninterruptible power supplies, dimmers, welding units</li> </ul>
<b>Causes linked to electrical power supply networks</b>	<ul style="list-style-type: none"> <li>• Propagation of harmonic pollution from customers supplied by the same electrical network</li> </ul>
<b>Parameters to be measured</b>	<ul style="list-style-type: none"> <li>• Global THD</li> <li>• Harmonics order by order in % and RMS value</li> </ul>

## FREQUENCY VARIATIONS

Frequency fluctuations are observed on non-interconnected networks and networks connected to electrical generator sets.

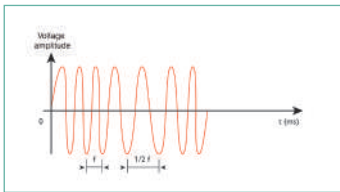

The average value of the fundamental frequency must be 50 Hz  $\pm$  1% in normal operating conditions.

<b>Faults generated</b>	<ul style="list-style-type: none"> <li>• Process shutdown</li> </ul>
<b>Causes linked to disturbances due to equipments</b>	<ul style="list-style-type: none"> <li>• Autonomous source control fault</li> </ul>
<b>Causes linked to electrical power supply networks</b>	<ul style="list-style-type: none"> <li>• After an overload on networks that are not interconnected or on an electrical generator set</li> </ul>
<b>Parameters to be measured</b>	<ul style="list-style-type: none"> <li>• Frequency F(Hz)</li> </ul>

## VOLTAGE SURGES

The maximum number of voltage surges during an observation period is usually monitored.

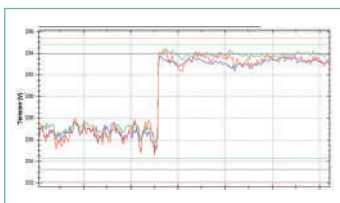

Surges of a few per cent which do not cause the voltage to deviate from the template  $\pm$  10 %.

<b>Faults generated</b>	<ul style="list-style-type: none"> <li>• Contributes to flicker, malfunction of the control systems acting on the phase angle, acceleration/deceleration torque of motors</li> <li>• Damage to sensitive electronic equipment</li> </ul>
<b>Causes linked to disturbances due to equipments</b>	<ul style="list-style-type: none"> <li>• Operations: motor startup, activation of a capacitor bank, activation of an inductance, etc.</li> </ul>
<b>Causes linked to electrical power supply networks</b>	<ul style="list-style-type: none"> <li>• Activation of load adjustment systems</li> <li>• Variation of production by independent producers (wind turbines, solar panels, etc.)</li> </ul>
<b>Parameters to be measured</b>	<ul style="list-style-type: none"> <li>• Voltage surges according to the IEC 61000-3-3 standard, difference between two stable states (voltage change less than or equal to 0.5 % for 1 second)</li> <li>• The characteristics of voltage surges are: duration (time between two stable states), largest voltage variation in relation to previous stable state (<math>U_{max}</math>), difference between the two stable states (<math>U_{stat}</math>)</li> </ul>

# MAP RANGE

Electrical network quality analyzers  
HV / MV / LV – Class A.



## GENERAL SPECIFICATIONS

The products in the **MAP** range, mounted on a platen or on the cabinet backplate, measure all the parameters of HV / MV / LV electrical networks: RMS voltage, frequency, THD, level of unbalance, positive/negative/zero sequence voltage, flicker, harmonics up to the 50th order, interharmonics up to the 50th group. For products with current channels: RMS current, THDi, active, reactive and apparent power, cos  $\phi$ , power factor, power values of harmonics, energy values (calculated by the software).

The products in the **MAP** range record and, via the associated software, provide detailed, comprehensive and continuous analysis of the quality of the electricity supplied according to the applicable standards, particularly EN 50160: voltage variations (voltage dips, swells and outages), rapid variations (transient overvoltages), flicker or rapid voltage fluctuations...

**The related software** can be used either to analyze an isolated MAP unit or to manage and retrieve the data remotely from the equipment installed.

**Various communication modes are available** for remote recovery of the data and in-depth analysis of all the recorded parameters.

## USER SECTORS



Industry



Energy  
generation



Energy  
transmission  
& distribution



- **Compliant with the EN 61000-4-30 standard, Class A**
- **Detection of the fault location direction (upstream/downstream) for products with current channels**
- **Analysis of transients with a high, variable sampling frequency**
- **Measurement of harmonics (up to 50th order) and interharmonics (up to 50th group)**
- **Flicker measurement: I<sub>fl</sub>, P<sub>st</sub>, P<sub>lt</sub>**
- **Processing of the data according to the EN 50160 standard**

**SINGLE-PHASE ANALYZER – CLASS A**

- 2 voltage channels: phase/neutral and phase/neutral-earth
- Plug & play: no driver required
- USB 2.0 communication port
- Configuration for voltage dips, overvoltages and transient disturbances
- Class A according to IEC 61000-4-30
- Measurement of all the power quality parameters according to the predefined standard (EN 50160, etc.)
- Direct indication on the product: Green LED: parameters OK  
Red LED: parameters outside profile



Inputs			
Voltage input (Phase-Neutral)	0-300 VRMS	Standard measurement (Class A)	1
Voltage input (Phase/Neutral-Earth)	0-300 VRMS, 700 Vpk		1
Power supply			
Power supply range	Power supply via voltage input		Yes
Internal back-up			Yes
Compliance with standards			
Sliding reference			Yes
IEC 61000-4-30, Class A	< 0.1 %	Reference equipment	Yes
IEC 61000-4-7		Measurement of harmonics	Yes
IEC 61000-4-15		Flicker measurement	Yes
EN 50 160 (European Norm)		Calculated in the unit	Yes
PQDIF format			Option
Hardware			
Memory	Circular Flash Memory (NAND)		64MB
Sampling rate			12.8 kHz (x2)
Accuracy	Class A		< 0.1 %
Resolution			16 bit
Input impedance – Input voltage			10 MΩ
Anti-aliasing filter			Yes
Bandwidth			3.5 kHz
PLL Synchronization			Yes
Communication			
USB port	2.0 (Full-speed)	For PC connection, detected automatically Driver not required	Yes
Measurement specifications			
All power quality parameters are measured and stored	Voltage (avg/min/max), Frequency, THD, Harmonics (up to 50th order), Flicker (Lfi, Pst, Ptt)		Yes
Analysis of rapid disturbances	Dips/swells (RMS 1/2 cycle), transients		Yes
Waveform capture	Programmable pre-time and post-time		Max. duration 200 cycles
Mechanical specifications			
Housing	For 230 V socket	Humidity: 10% - 85% without condensation	
Dimensions (L x H x W)	120 x 65 x 65 mm		
Weight	0.3 kg	Safety: EN 61 010-1	
Operating temperature	-10 °C +55 °C	EMC: EN 58 081-1,2; EN 50 082-1,2	

**TO ORDER**

Model	Reference
<b>Package includes:</b> - MAP607 - mini USB cable - Qual-view and Qual-SRT software - carrying case	MAP607-P



METERS AND POWER MONITORS  
 NETWORK MONITORING FROM LV TO HV  
 CURRENT TRANSFORMERS AND SHUNTS  
 TRANSDUCERS  
 PANEL METERS AND SYNCHROCOUPLER  
 AUXILIARY RELAYS  
 CIVILIAN AND MILITARY NAVAL APPLICATIONS  
 SERVICES AND TRAINING

# MAP COMPACT

Compact Power Quality Analyzer – Class A with monitoring of EN50160 template and calculation of energy values



- Integrated EN50160 reports
- Display
- Measurement of network quality and energy in kWh / kVarh
- Compact format

## USER SECTORS



## GENERAL SPECIFICATIONS

- Built-in display
- Measurement compliant with IEC 61000-4-30 Class A
- Integrated EN50160 and NRS048 report generation function
- Recording of voltage dips / swells / outages
- Waveform capture with programmable pre-time and post-time
- Measurement of power and energy values as primary quantities
- Communication interfaces
- Compact format for installation in existing cabinets

## Specifications

Inputs		Specifications	
PH/N, PH/PH voltage input	3	0-364/0-630 VRMS	Impedance 1 MΩ
Current input	3	0-6 A RMS	Impedance 10 mΩ
CT and VT ratio	■		
<b>Sampling and algorithmic conformity</b>			
Sampling		12.8 kHz / 16 bits	Anti-aliasing filter and PLL synchronization
Bandwidth		3.5 kHz	
Network quality		IEC 61000-4-30 Class A	
Harmonics		IEC 61000-4-7	50th order
Flicker		IEC 61000-4-15	
Voltage surges		IEC 61000-3-3	
Template monitoring		EN50160 / NRS048	
<b>Parameters measured</b>			
Voltage	■		EN50160 / NRS048
Frequency	■		EN50160 / NRS048
Unbalance	■		EN50160 / NRS048
Harmonics	■		EN50160 / NRS048
Flicker (Pst, Plt, Ifl)	■		EN50160 / NRS048
Current	■		10 min
Power	■	P/Q/S, PF, Cosφ	Selectable integration
Energy	■	kWh, kVarh	Selectable integration
<b>Storage, communication and display</b>			
Mini-USB	■		
CL port	■		
RS232 port	■		
Ethernet port	Available as an option		
Storage capacity	Flash, circular	64 MB	
Display	Navigation keys	3 lines	U, I, events
<b>Power supply and power reserve</b>			
Power supply		175 Vac to 255 Vac	
Internal power reserve		10 s	
<b>Mechanical specifications</b>			
Dimensions		155 x 165 x 68 mm	
Weight		0.9 kg	
Operating temperature		-10 °C , +55 °C	

# Connection systems

## MAP permanent analyzers

**MAP Compact**

Screw-on connectors

**Voltage**



**Current**



### TO ORDER

	Reference
<b>MAP COMPACT without Ethernet</b>	P01 3400 10
<b>MAP COMPACT with Ethernet</b>	P01 3400 20

METERS AND POWER MONITORS  
 NETWORK MONITORING FROM LV TO HV  
 CURRENT TRANSFORMERS AND SHUNTS  
 TRANSDUCERS  
 PANEL METERS AND SYNCHROCOUPLER  
 AUXILIARY RELAYS  
 CIVILIAN AND MILITARY NAVAL APPLICATIONS  
 SERVICES AND TRAINING

# MAP SOFTWARE RANGE

Management and analysis software for the MAP range.



## USER SECTORS



Industry



Energy generation



Energy transmission & distribution

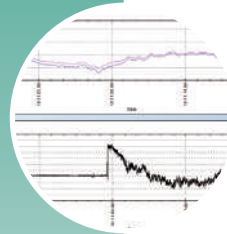

Graphic display of all the available parameters



Configuration and manual or automatic retrieval of the data



Generation of reports

## DESCRIPTION

Depending on the model, the range of software for MAP allows:

- configuration of the MAP
- creation of call sessions
- display of the electrical parameters (monitoring mode)
- retrieval of recorded data
- analysis of the disturbances and transients
- EN 50160 analysis
- a point-to-point or client/server architecture
- an automatic data retrieval engine
- multi-equipment analysis sessions
- external synchronization by server
- an event viewer module for duty control rooms
- report printing
- transmission of alarms by email, SMS, etc.



- Particularly user-friendly software
- Analysis and diagnostics according to the applicable standards
- Set-up of all the parameters in the EN 50160 standard on a single screen
- Qual-Web module for all your quality measurements in your web browser

## Recommended configuration

### PC platform:

- operating system: Windows XP Pro SP3 / Vista / Seven / Server 2003 SP2 / Server 2008 / Server 2010
- processor frequency  $\geq$  2.0 GHz with dual-core architecture (e.g. Pentium or Intel Core 2 Duo)
- RAM  $\geq$  2 GB
- hard disk  $\geq$  250 GB with 240 MB free
- Ethernet network board

## For MAP 607 and MAP Compact

Configuration and real-time display module for "online" display of:

- the measurements
- the number of dips/ voltage surges / long outages / short outages / transients recorded
- the global status of the last EN50160 report
- the memory occupation rate
- the date and time on the equipment

Dynamic views are also available: the trend graph (recorder-type view) and the bargraph of harmonics up to the 50th order. Thanks to the self-declaring ultra-fast USB2.0 link, this module can be used for almost instantaneous recovery of the data while deleting them from the equipment.

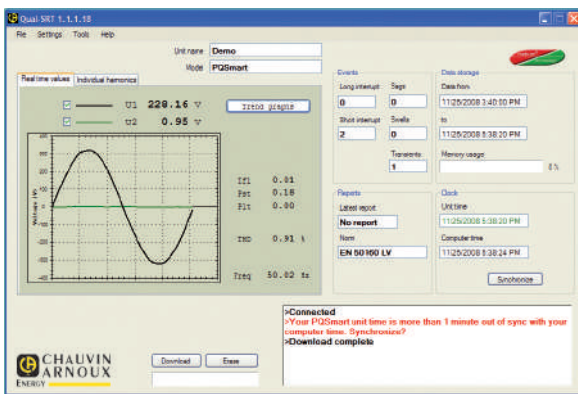

Qual-SRT: real-time display of the waveform connected to a MAP 607

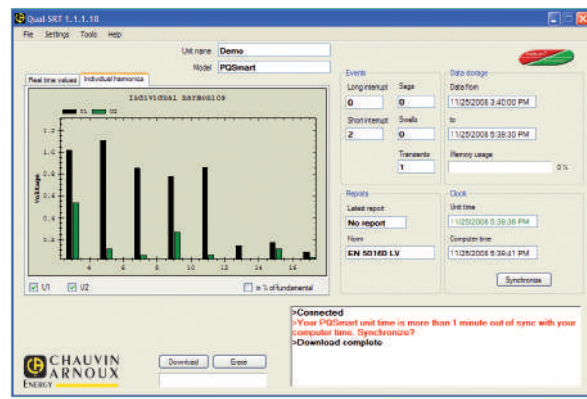

Qual-SRT: real-time display of the harmonics bargraph

### TO ORDER

Description	Reference
Configuration software for MAP 607	QUAL-SRT
Configuration software for MAP Compac	QUAL-SRTc

### ASSOCIATED PRODUCTS



**MAP 607**  
Single-phase voltage quality analyzer  
page 87



**MAP Compact**  
Compact power and network quality analyzer  
page 88

## Qual-VIEW

### Analysis and report generation module for MAP network analyzers.

This provides a view of all the trend curves generated by the equipment, with the possibility of zooming and graphical display of the qualimetry template limits for each parameter.

The event-based views such as the event signatures, waveforms and time/date-stamped events log can also be obtained by means of dedicated tabs in the Qual-View software.

- For discussing the quality of the energy supply at the point of connection
- Intuitive, user-friendly and simple to use in order to track the most complex phenomena
- For assessing the evolution of energy quality over time and measuring its impact on ageing of the installation and the size of your energy bill

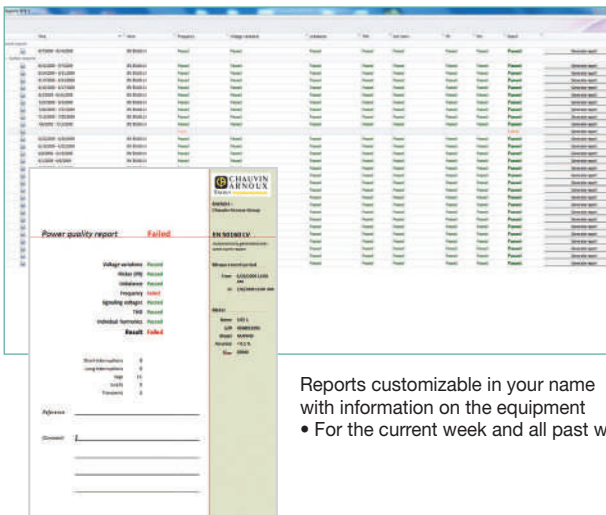

Reports customizable in your name with information on the equipment

- For the current week and all past weeks

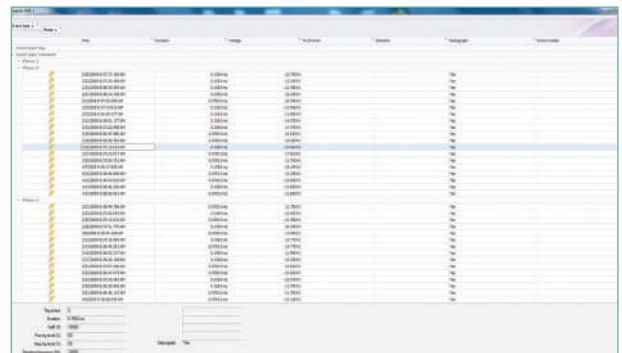

A history of all the events listed according to their type

- Relevant sorting systems (type, phase concerned, upstream/downstream, etc.)
- A summary of each time/date-stamped event along with a snapshot

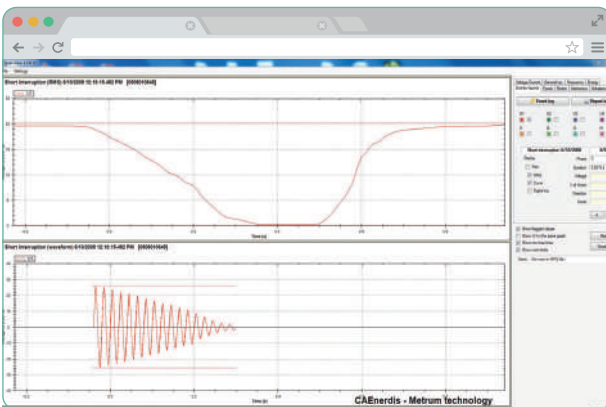

Understand the causes of network outages

- What happened?
- Does it come from my installation?
- Observe the waveform of the event affecting delivery of the energy as a voltage
- Compare this event with the waveform of the current

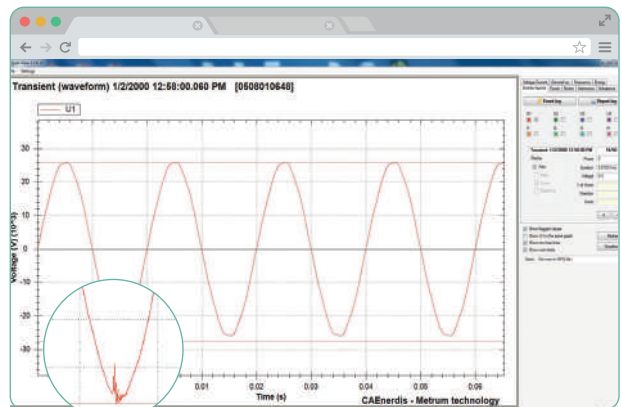

Benefit from all the tools needed for in-depth troubleshooting

- Zoom on the waveform at the time of the event (current or voltage)
- Display of the briefest phenomena distorting the waveform

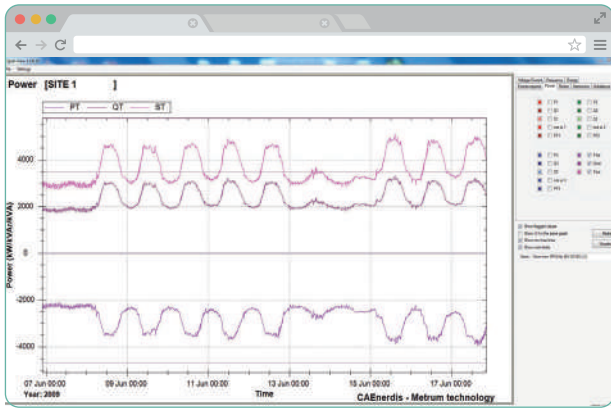

An approach covering periods from 1 year down to 1 hour to detect the network's behaviour in the variations of power and active energy consumption

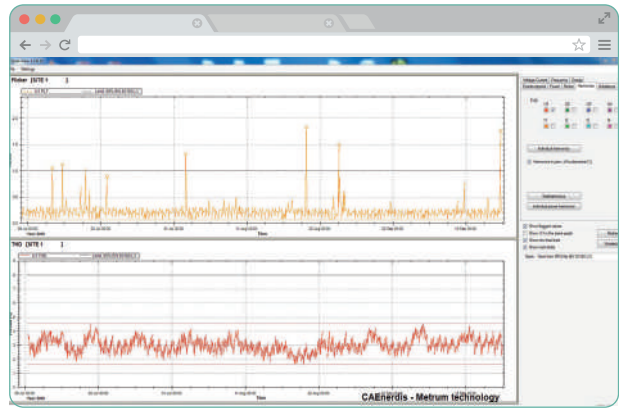

Maintaining the site and limiting the harmful effects of disturbances over the long term

- Benefit from a 10-minute approach for all the electrical quantities simultaneously:
  - The distorting power THDi vs. the apparent power S
  - Flicker disturbances
  - Frequency and unbalance
  - Harmonics and their components

## TO ORDER

Description	Reference
Configuration, display and analysis software	MAP-QV

## ASSOCIATED PRODUCTS



**MAP 607**  
Single-phase voltage quality analyzer  
page 87



**MAP Compact**  
Compact power and network quality analyzer  
page 88

METERS AND POWER MONITORS

NETWORK MONITORING FROM LV TO HV

CURRENT TRANSFORMERS AND SHUNTS

TRANSDUCERS

PANEL METERS AND SYNCHROCOUPLER

AUXILIARY RELAYS

CIVILIAN AND MILITARY NAVAL APPLICATIONS

SERVICES AND TRAINING

## E.Qual-Premium Server

### Analysis and report generation module for MAP network analyzers.

**E.Qual-Premium Server** is a unique, user-friendly solution for managing from ten to several hundred network analyzers.

**E.Qual-Premium Server** also includes E.Qual-Premium:

- graphical multi-equipment views
- multi-equipment event logs
- statistical views

**Peace of mind:** all the data retrievals are performed automatically by a high-performance remote data-retrieval engine

**Complete:** a history from the moment the equipment fleet was commissioned, allowing benchmarking of all the analyzers

**Analysis:** special tools for summarizing the measurements on the fleet of analyzers and sharing the information in concise form with the decision-makers and operators

### Architecture of E.Qual-Premium Server

The **E.Qual-Premium Server** architecture is ideal for applications where you want to analyze the energy quality measurements gathered from several points in the electrical network and compile data supplied by different models in the MAP range. Thanks to its automatic remote retrieval engine, the E.Qual-Premium Server software is capable of transferring the data from the different network analyzers and integrating them into the system's SQL-server® base. The multi-equipment analysis module can then use the measurements stored in the database to generate composite views and statistics grouping information from several measurement points.

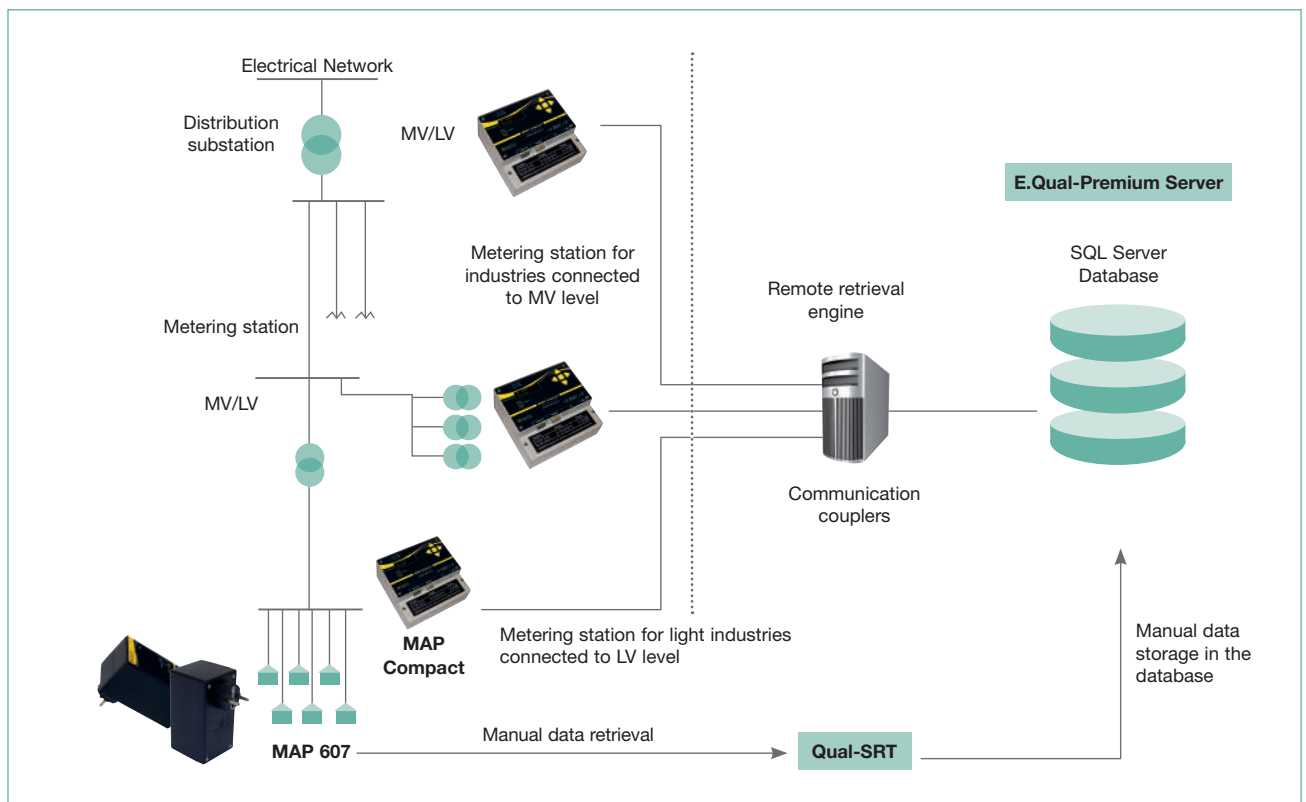

Components of an E.Qual-Premium Server with the network analyzers, the communication links, the database and the analysis and graphic display modules.

Analytical and statistical tools

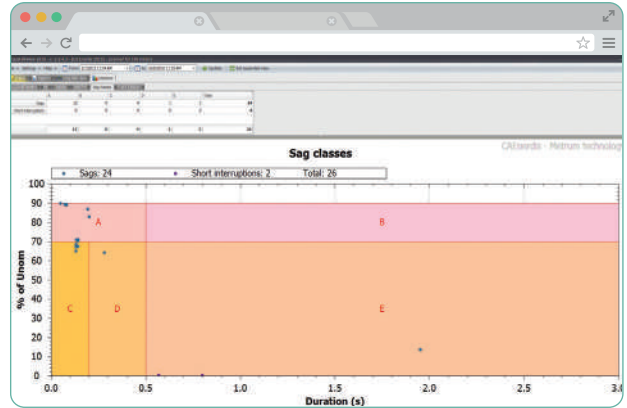
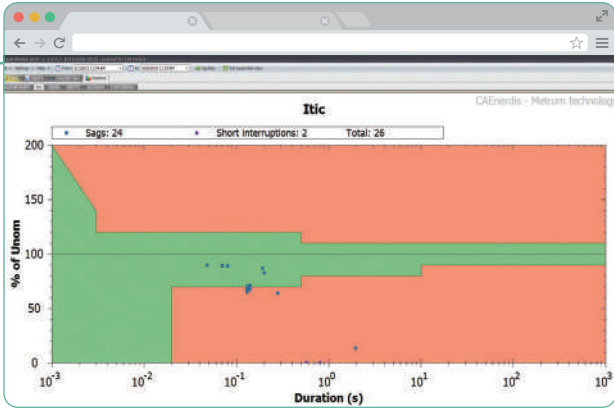

The statistical distributions used for electrical network management

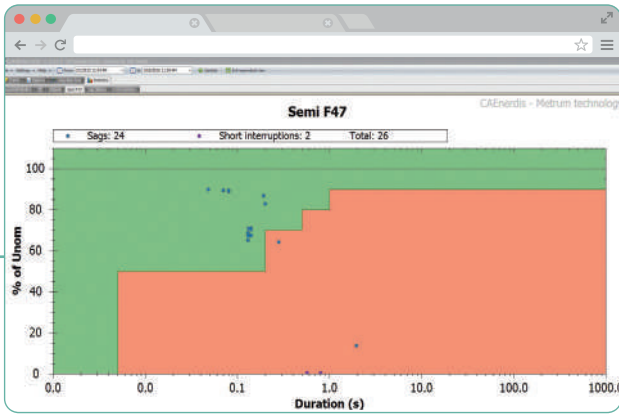

The sector-specific analytical tools for IT environments and sensitive industrial processes

TO ORDER

Models	Description	Number of licenses	Reference
E.Qual-Premium Server	Configuration, remote data retrieval, display, administration and analysis software	5	P01340123
E.Qual-Premium Server	Configuration, remote data retrieval, display, administration and analysis software	20	P01340122

ASSOCIATED PRODUCTS



MAP Compact

Three-phase network quality analyzer  
page 88

METERS AND POWER MONITORS  
NETWORK MONITORING FROM LV TO HV  
CURRENT TRANSFORMERS AND SHUNTS  
TRANSDUCCERS  
PANEL METERS AND SYNCHROCOUPLER  
AUXILIARY RELAYS  
CIVILIAN AND MILITARY NAVAL APPLICATIONS  
SERVICES AND TRAINING

## Qual-Web

### Key information from the qualimetry database available in a web browser

Add-on module for E.Qual-Premium Server enabling transmission of the information from the database to other users (operators, customers, management, etc.) which does not require any local software installation.

- Management of EN50160 report generation and events
- Access manager: the administrator can limit access to a selection of devices for the various users.

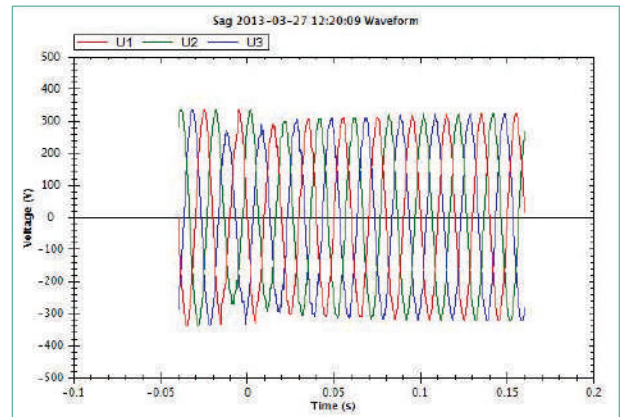
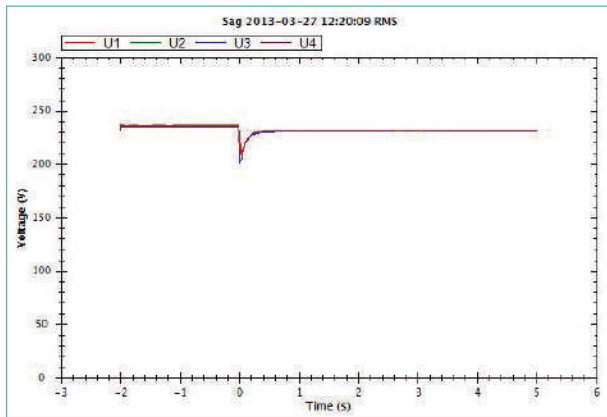

Time	Phase	Voltage (V)	Current (A)	Power (W)	Power Factor	Frequency (Hz)	Harmonics (%)	THD (%)	Event Type	Status
2013-03-27 12:20:09.000	U1	230	10	2300	0.95	50	5	5	Sag	Resolved
2013-03-27 12:20:09.000	U2	230	10	2300	0.95	50	5	5	Sag	Resolved
2013-03-27 12:20:09.000	U3	230	10	2300	0.95	50	5	5	Sag	Resolved
2013-03-27 12:20:09.000	U4	230	10	2300	0.95	50	5	5	Sag	Resolved



# GRIDWATCH

## SOLUTION FOR SUPERVISION OF LV INSTALLATIONS

A tailored solution based on integration of the Ulys MCM multichannel meter

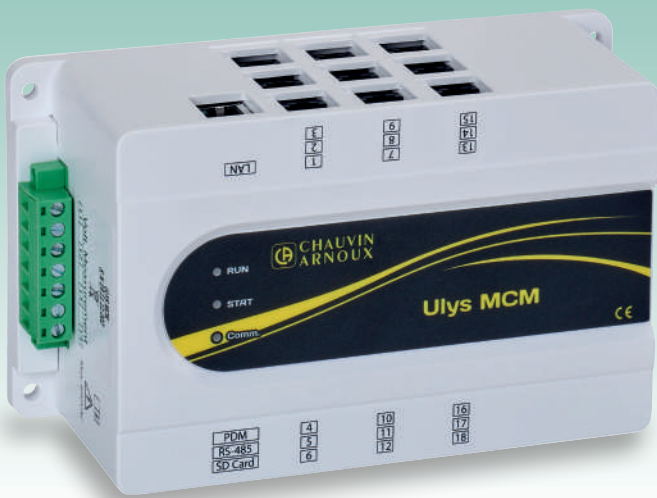

### ANTICIPATE

Aging of the transformer and installations

Optimized scheduling and reduced maintenance costs



### TRACK AND SECURE

The energy flows

Reduced technical and non-technical losses



### OPTIMIZE

The installations and new connections

Assessment of the available reserve or the effective overload on the feeders or transformers

Workstation ventilation control



Smoke detection, fire outbreak



Calculation of high voltage and current

MV feed

HTA transformer input

HTA cells

DDS

Detection of door opening or movement in the workstation

Monitoring of the underground 'Insulation Fault Detector'

Monitoring of hot spots and humidity in high-voltage cells

Monitoring of hot spots at the connection points of low-voltage transformer and high-voltage transform

**USER SECTORS**



Industry



Energy transmission & distribution



Software Gridwatch dashboard



**GRIDWATCH MEASUREMENT BOX**



Measurement of transformer currents, voltages and LV power ratings



Calculation of load factor and transformer imbalance



Measurement of currents and power for the 3 phases and neutral (optional) of each LV output

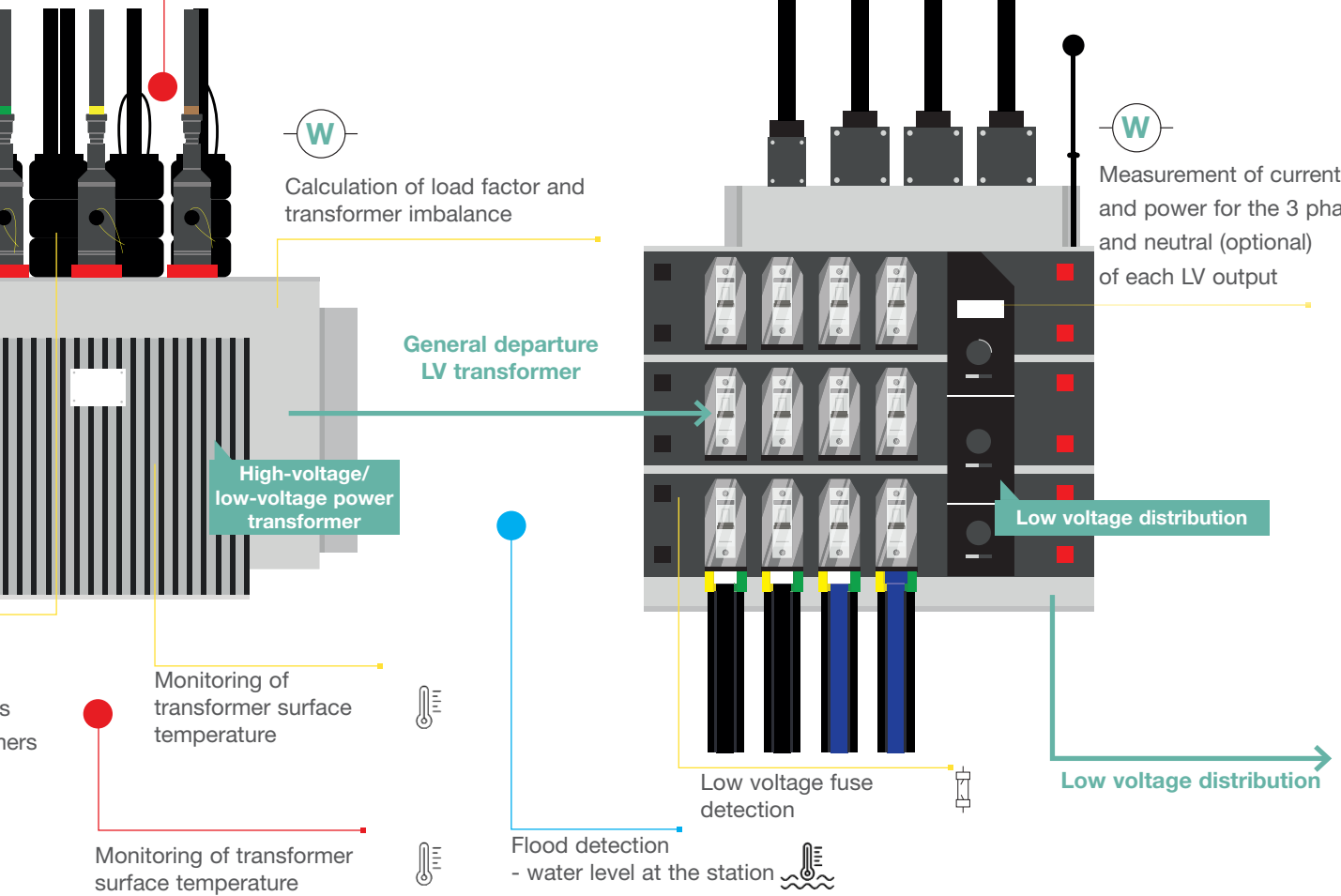

METERS AND POWER MONITORS

NETWORK MONITORING FROM LV TO HV

CURRENT TRANSFORMERS AND SHUNTS

TRANSDUCERS

PANEL METERS AND SYNCHROCOUPLER

AUXILIARY RELAYS

CIVILIAN AND MILITARY NAVAL APPLICATIONS

SERVICES AND TRAINING

## Strengths



### Comprehensive and scalable



**GridWatch includes all the sensors needed to monitor critical points in the HV/LV substation.**

Available in different versions, it adapts to the size and budget available for **optimal deployment**.

GridWatch will gradually be equipped with sensors to instrument the transformer and the substation's LV electrical outputs.

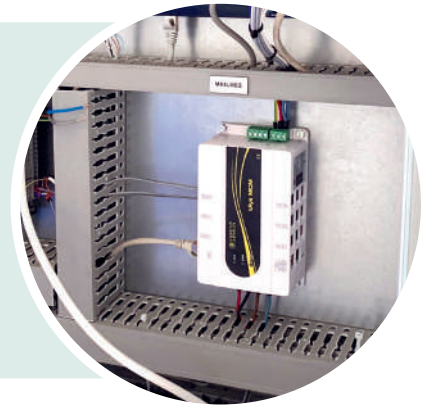

### Rapid deployment



To reduce downtime during system commissioning, **GridWatch has been designed for quick installation and deployment:** current sensors that open and connect with a single click, pre-wired environmental measurement sensors, pre-configured wireless hotspot sensors, etc.



### Compatible with all systems



With multiple communication protocols (Modbus, MQTT, FTP, etc.) on WAN (3G/4G, Ethernet) and LAN interfaces, GridWatch is compatible with numerous monitoring systems (SCADA, supervisors, web applications, etc.).

Measurements, alarms and sensor statuses on the transformer, LV panel and substation cell are available in real time.

Alarms are sent by email, MQTT, etc. GridWatch Dashboard is the turnkey software solution for monitoring a fleet of Gridwatch cabinets.



## USER SECTORS



Industry



Energy  
transmission  
& distribution

### GridWatch C200 Measurement - Control - Command

### GridWatch C50 Measurement - Control

#### Measurement and analysis of substation structure behaviour

<b>Transformer:</b> Electrical measurement and metering at the secondary level of the main transformer HTA/BT	<ul style="list-style-type: none"> <li>• 3P+N voltage measurement on input terminal block</li> <li>• Quick-install Rogowski-type current sensor (diameter 200 mm) (phases + neutral)</li> <li>• Measured quantities: V, U, I, F, P, Q, S, PF, Ea, Eq, Es</li> <li>• Calculated high voltage quantities: U, I</li> </ul>	
<b>Low voltage electrical outlets:</b> Electrical measurement and metering on each outlet and per phase.	<ul style="list-style-type: none"> <li>• Compact, quick-installation TC current sensors (up to 8 outputs)</li> <li>• Compact Rogowski-type current sensors (70 mm diameter) quick installation (up to 8 outputs)</li> <li>• Measured quantities: V, U, I, F, P, Q, S, PF, Ea, Eq, Es</li> </ul>	
<b>Measurement of temperatures at hot spots at the connection points of the LV transformer (Qty: 4) and HTA (Qty: 3)</b>	Yes (7 wireless sensors)	No
<b>Measurement of the surface temperature of the transformer</b>	Yes (Wired temperature sensor)	
<b>Measurement of the ambient temperature in the HS9 substation</b>	Yes (wired temperature sensor)	No
<b>Measurement of the ambient temperature in the HS9 substation</b>	Digital inputs/outputs	No
<b>Ability to interface with other components of the electrical substation</b>	Analogue inputs and digital inputs and outputs available	-

#### Communication and data management

<b>Communication mode</b>	WAN interface (3G/4G and RJ-45 port) LAN interface (RJ-45 port)	
<b>Data visualisation</b>	Pages web embarquées (HTTP) et GridWatch Dashboard	GridWatch Dashboard
<b>Alarm management and data logging</b> <b>Data logging</b>	Yes (journal, e-mail, FTP, etc.) and via GridWatch Dashboard solution	via GridWatch Dashboard solution
<b>Protocols in simultaneous use</b>	<ul style="list-style-type: none"> <li>• Modbus TCP: Access to all electrical and physical parameters in real time (1 sec)</li> <li>• MQTT: Publisher mode for alarms</li> <li>• MQTT: Publisher mode for measurements</li> <li>• Push FTP: File transfer to FTP server (alarms and recordings) <ul style="list-style-type: none"> <li>• SMTP: Email</li> </ul> </li> <li>• NTP: Date/time synchronisation</li> </ul>	MQTT: Publisher mode for measurements
<b>Remote administration</b>	Yes	Yes

#### General characteristics

<b>Remote local data display screen</b>	Yes (option)	Yes (option)
<b>Dimensions</b>	600x400x250 mm	310x260xl 70 mm
<b>Operating temperature</b>	-10°C to +55°C	
<b>Installation</b>	Wall or floor mounting	Wall mounting
<b>Compliant</b>	IEC 61439-1 / IEC 61439-5	
<b>Battery operation in the event of a power cut</b>	Yes	No
<b>Three-phase surge protection (external installation)</b>	Option	

#### Supervision application

<b>GRIDWATCH Dashboard (multiproduit, multiutilisateur)</b>	Yes
---	-----

**Request a quote to equip your electrical substation monitoring projects!**

## Gridwatch Dashboard Software

The Gridwatch Dashboard web application displays, processes, monitors, alerts and formats measurement data collected by C50 and C200 boxes on HV/LV transformers and LV feeders. The data is periodically transmitted (every 10 seconds as standard) to an MQTT broker.

The main features of GRIDWATCH DASHBOARD are:

- **SUPERVISION** : Geolocate HV/LV transformers equipped with a GRIDWATCH box.
- **DASHBOARDS** : Display KPIs (Key Performance Indicators) for transformer monitoring (load rate, temperature, imbalance) and LV outputs.
- **MONITORING** : View real-time measurements taken on HV/LV transformers and LV feeders.
- **ANALYSIS** : Graphs showing the evolution of measurements over time (10-minute, hourly, daily, weekly and monthly averages).
- **ALARMS** : Set alarms for the parameters collected by the application, with targeted emails sent to the electrical network's operations and maintenance operators.

## Page Station : DASHBOARDS, KPIs, MONITORING and ANALYSIS of HV/LV transformers



Immediately identify abnormal operating conditions of the HV/LV transformer using the KPI colour code. The 'Real time data' table provides real-time information on changes in measurements.

- Display graphs over long periods of time showing average values for 10 minutes, hourly, daily, weekly and monthly periods.

### FEEDERS (LV DEPARTURES)



View the electrical values measured on the LV feeders in real time.

- Identify the most heavily used feeders.
- Compare the loads per phase on the feeders to identify imbalances.

### ALARMS

Date	Al.	Name	Topic	Period	Configuration	Detected value	Acked date
14/11/2025 02:00	●	VRE_Freq_1 hour average	VRE/VRETR1/REL/Header	1 hour(0)	frequency = 60	63.01	Not acked.
14/11/2025 01:20	●	VRE_Freq_1 hour duration	VRE/VRETR1/REL/Header	Instantaneous	frequency = 60	63.00	Not acked.
14/11/2025 00:30	●	VRE_Freq_10 min duration_60	VRE/VRETR1/REL/Header	Instantaneous	frequency = 60	63.00	Not acked.
14/11/2025 00:30	●	VRE_Freq_10 min average	VRE/VRETR1/REL/Header	10 minute(s)	frequency = 60	63.01	14/11/2025 04:30 Not acked.
14/11/2025 00:30	●	VRE_Freq_On Data	VRE/VRETR1/REL/Header	Instantaneous	frequency = 60	63.00	14/11/2025 04:21 Not acked.

Numerous alarm configuration modes for collected measurements.

- Quick programming mode for a fleet of several hundred C50 and C200 cabinets.
- Send targeted email messages when alarms are activated.





NETWORK SUPERVISION AND PHYSICAL MEASUREMENT

# CURRENT TRANSFORMERS AND SHUNTS



- 106 OVERVIEW OF THE RANGE
- 108 SELECTION GUIDE
- 114 TERTIARY AND INDUSTRIAL CURRENT TRANSFORMERS
- 126 CURRENT TRANSFORMERS FOR TARIFF METERING
- 137 CURRENT TOTALIZERS
- 138 CT SHORT-CIRCUITER
- 140 SHUNTS

METERS AND  
POWER MONITORS

NETWORK MONITORING  
FROM LV TO HV

CURRENT TRANSFORMERS  
AND SHUNTS

TRANSDUCERS

PANEL METERS AND  
SYNCHROCOUPLER

AUXILIARY RELAYS

CIVILIAN AND MILITARY  
NAVAL APPLICATIONS

SERVICES AND TRAINING

# CURRENT TRANSFORMERS AND SHUNTS

## TERTIARY AND INDUSTRIAL CURRENT TRANSFORMERS



**TCR**  
Wound primary  
Class 0.5/1/3  
page 115



**TCR**  
Cable/busbar primary  
Class 0.5/1/3  
page 116



**JVS**  
Cable/busbar primary  
Class 0.2s  
page 119



**TCRO**  
Split core  
Without conductor opening  
page 122



**TC CLIP**  
Split core  
Small volume  
page 126

## CURRENT TRANSFORMERS FOR TARIFF METERING

### CORE – SINGLE-PHASE



**JVR86**  
Wound primary  
M8-M10  
page 129



**JVO 40-100**  
Cable primary  
Ø 42 mm - Class 0.5  
page 131



**JVO 40-100 S**  
Cable primary  
Ø 40 mm - Class 0.2s  
page 132



**J3R 80B**  
Cable primary  
Ø 66 mm - Class 0.5  
page 129



**JVO 90-160S**  
Cable primary  
Ø 90 mm - Class 0.2s  
page 133



**JVS 38B**  
Cable/ busbar primary  
Ø 63 mm - Class 0.2s  
page 120



**JVP 1025**  
Busbar primary  
100 x 20 - Class 0.5  
page 129



**JVP 1045**  
Busbar primary  
100 x 40 - Class 0.5  
page 129



**JVP 1045B**  
Busbar primary  
100 x 40 - Class 0.5  
Bi-Rating  
page 130



**JVP 1145S**  
Busbar primary  
100 x 12 - Class 0.2s  
page 134

## USER SECTORS



Tertiary



Industry



Energy transmission & distribution



Energy efficiency



Naval applications

METERS AND POWER MONITORS

NETWORK MONITORING FROM LV TO HV

CURRENT TRANSFORMERS AND SHUNTS

TRANSDUCCERS

PANEL METERS AND SYNCHROCOUPLER

AUXILIARY RELAYS

CIVILIAN AND MILITARY NAVAL APPLICATIONS

SERVICES AND TRAINING

## CURRENT TRANSFORMERS FOR TARIFF METERING

### PLATE-MOUNTING - THREE-PHASE



#### TRI 500 Single-rating

50 to 240 mm<sup>2</sup> cable clamp  
Class 0.5  
page 135



#### TRI 700 Three-rating

50 to 240 mm<sup>2</sup> cable clamp  
Class 0.5  
page 136



#### TRI 700 S Two-rating

50 to 240 mm<sup>2</sup> cable clamp  
Class 0.2  
page 136

## CURRENT TOTALIZERS



#### JVM 15

CT designed to add together the instantaneous current values from the secondaries of 2 or 3 current transformers.  
page 137

## CT SHORT-CIRCUITER



#### PRTC

Protection against the hazards due to opening of the secondary circuit of a low-voltage measurement CT.  
page 138

## SHUNTS

### CLASS 0.5



#### 76/2 - 77/2 range

1 to 4.000 A  
A reference for measurement in demanding applications.  
page 142

### CLASS 1



#### SHMI range<sup>1</sup> to 6.000 A

Vast choice for industrial applications.  
page 144



#### SHEL range

10 to 300 A  
At low power, everything you need to facilitate implementation.  
page 146



#### SHMO range

1 to 60 A  
DIN-rail mounting.  
page 146

# CHOOSING YOUR TRANSFORMER

## CURRENT TERTIARY AND INDUSTRIAL

### TCR Wound primary

page 115



### TCR/JVS Cable/busbar primary

page 121



	TCR10	TCR15	TCR20	TCR22-30	TCR28-40 JVS 28-40 ●	TCR43-60 JVS 43-60 ●	TCR63-80	
Accuracy class	0,5 / 1 / 3	0,5 / 1 / 3	0,5 / 1 / 3	0,5 / 1 / 3	0,5 / 1 / 3 0,2s	0,5 / 1 / 3 0,2s	0,5 / 1 / 3 0,2s	
Wound primary (threaded rod)	Aperture 25 x 25	Wire 16 mm <sup>2</sup>						
Cable primary (mm)			Ø 20	Ø 22	Ø 28	Ø 43	Ø 63	
Busbar primary (mm)				25 x 10 30 x 10 20 x 12	20 x 25 30 x 15 40 x 10	50 x 30 60 x 12 12 x 45	50 x 50 60 x 30 80 x 30	
	Primary	5 A	■	■				
		10 A	■	■				
15 A			■					
20 A			■					
25 A			■					
30 A			■					
40 A				■				
50 A		■	■	■				
60 A		■		■				
75 A		■		■				
100 A				■	■			
125 A		■		■	■			
150 A				■	■	■ / ●		
200 A				■	■	■ / ●		
250 A					■	■ / ●		
300 A					■	■ / ●		
400 A					■	■ / ●		
500 A						■ / ●		
600 A					■	■	■ / ●	
750 A							■ / ●	
800 A							■ / ●	
1000 A							■ / ●	
1200 A							■	
1500 A								■
2000 A							■	
2500 A							■	
3000 A							■	
4000 A								
5000 A								

## USER SECTORS



Tertiary



Industry



Energy efficiency



Naval applications

### TCRO Split core

page 122



### TC CLIP Split core

page 126



TCRO 2030	TCRO6080	TCRO80120	TCRO80160	TCC16	TCC24	TCC24	TCC36	TCC36
0,5 / 1 / 3	0,5 / 1 / 3	0,5 / 1 / 3	0,5 / 1 / 3	1	1	0,5	0,5	0,5
				Ø 16	Ø 24	Ø 24	Ø 36	Ø 36
20 x 30	60 x 80	80 x 120	80 x 160					

METERS AND POWER MONITORS

NETWORK MONITORING FROM LV TO HV

CURRENT TRANSFORMERS AND SHUNTS

TRANSDUCERS

PANEL METERS AND SYNCHROCOUPLER

AUXILIARY RELAYS

CIVILIAN AND MILITARY NAVAL APPLICATIONS

SERVICES AND TRAINING

# CHOOSING YOUR CURRENT TRANSFORMER

## FOR TARIFF METERING

### Core - Single-phase

page 129

page 131

page 132

page 129

page 133



JVR 86

JVO 40-100

JVO 40-100 S

J3R 80B

JVO 90-160 S

Type of connection	Wound primary	Ø M8/M10 > 75 A				
	Cable primary (diameter mm)		Ø 42	Ø 40	Ø 66	Ø 90
Busbar primary (mm)						
Cable clamp (section mm <sup>2</sup> )						
Accuracy	Accuracy class	0.5	0.5	0.2s	0.5	0.2s
	Precision power (VA)	20	7.5 (two-Rating) / 15	7.5	15 (5 for 300 A 10 for 400 A)	7.5
Rating	Single-rating	■	■		■	
	Two-rating		200 - 500 A	200-500 A		
	Three-rating					500 - 1000 - 2000 A
Primary	5 / 5 A	■*				
	20 / 5 A	■*				
	40 / 5 A	■*				
	50 / 5 A	■				
	60 / 5 A	■*				
	75 / 5 A	■				
	100 / 5 A	■*				
	150 / 5 A	■				
	200 / 5 A	■	■	■		
	250 / 5 A					
	300 / 5 A				■*	
	400 / 5 A				■*	
	500 / 5 A		■	■	■*	■
	600 / 5 A				■*	
	750 / 5 A				■*	
	800 / 5 A					
	1 000 / 5 A				■*	■
	1 200 / 5 A					
	1 250 / 5 A				■	
	1 500 / 5 A				■	
	2 000 / 5 A					■
2 500 / 5 A						
3 000 / 5 A						

\* Also available with 1 A secondary. Please contact us.

# USER SECTORS



## Core - Single-phase

## Plate-mounting - Three-phase

page 129

page 129

page 130

page 134

page 135

page 136

page 136



**JVP 1025**

**JVP 1045**

**JVP 1045B**

**JVP 1145 S**

**TRI 500**

**TRI 700**

**TRI 700 S**

100 x 20

100 x 40

100 x 40

100 x 12

50 to 240

50 to 240

50 to 240

0.5

0.5

0.5

0.2s

0.5

0.5

0.2s

15 (30 for 1 250 A)

15 (30 for 1 000 A)

7.5 (two-Rating) / 15

7.5

15

3.75

7.5



500 - 1 000 A  
1 000 - 2 000 A

50-100 A  
100-200 A  
200-500 A

500-1000-2000A

100 - 200 - 500 A



METERS AND POWER MONITORS  
NETWORK MONITORING FROM LV TO HV  
CURRENT TRANSFORMERS AND SHUNTS  
TRANSDUCERS  
PANEL METERS AND SYNCHROCOUPLER  
AUXILIARY RELAYS  
CIVILIAN AND MILITARY NAVAL APPLICATIONS  
SERVICES AND TRAINING

# INFO & ADVICE

## TRANSFORMERS



### FUNCTION

Current transformers power low-voltage measuring instruments and isolate them from the network. They supply their secondary winding with a standard current proportional to the primary current. They are divided into four main families:

- wound primaries;
- split-core primaries;
- cable primaries;
- busbar primaries

These transformers can be used with all types of measuring instruments: ammeters, energy meters, power monitors, etc.

### HOW TO CHOOSE A CURRENT TRANSFORMER

The choice is based on two main criteria:

- the current on the primary (transformation ratio  $I_p / 5 \text{ A}$ );
- the type of installation.

In other words, the choice depends on the type of cable or busbar on the installation and the intensity of the currents flowing through them.



### DETERMINING A CT'S ACCURACY CLASS

The accuracy class of a current transformer depends on the transformer's apparent power (VA) and the consumption of the entire measurement line. It is the result of the measurement errors of each element in the line and must therefore be less than or equal to the accuracy class of the measuring instrument which it supplies, particularly for energy metering where accuracy has a direct impact on billing. For a given accuracy class, the measurement line's consumption must not exceed the current transformer's apparent power (VA).

### Example of measurement chain consumption at 20 °C

Power dissipated per meter of line (2 ways)

Copper-wire section (mm <sup>2</sup> )	Secondary 5A	Secondary 1A
1.5 mm <sup>2</sup>	0.61 VA	0.025 VA
2.5 mm <sup>2</sup>	0.37 VA	0.015 VA
4 mm <sup>2</sup>	0.23 VA	0.009 VA
6 mm <sup>2</sup>	0.15 VA	0.006 VA

Enerium 50 Power Monitor	0.15 VA
5 m of double 2.5 mm <sup>2</sup> wire	$0.37 \times 5 = 1.85 \text{ VA}$
Measurement line consumption	$0.15 + 1.85 = 2 \text{ VA}$



### Power (VA) on Class

Primary	0.5	1	3
100 A	-	1	1.5
125 A	-	1	1.5
150 A	1	1.75	2.5
200 A	1.5	2.75	3.75
250 A	2	3.25	3.75
300 A	2.5	3.25	4
400 A	3	3.75	5
500 A	3.5	3.75	5
600 A	3.75	5	7.5

The transformer's accuracy class can then be deduced from the results obtained by referring to the table opposite (provided as an example):

- Class 3 for a CT with a ratio of 150/5
- Class 1 for a CT with a ratio of 200/5
- Class 0.5 for a CT with a ratio of 250/5

## USER SECTORS



Tertiary



Industry



Energy  
transmission  
& distribution



Energy  
efficiency



Naval  
applications

## CONNECTING A CURRENT TRANSFORMER

Chauvin Arnoux Energy current transformers offer 4 types of connection:

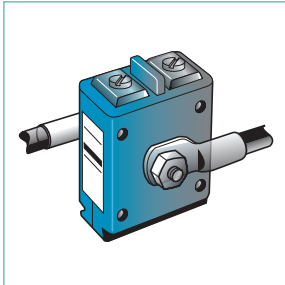

**WOUND PRIMARY**  
for currents less than 200 A

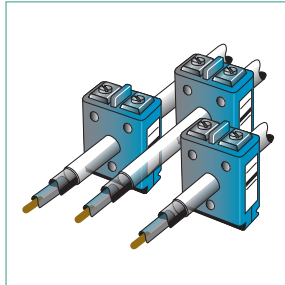

**CABLE PRIMARY**  
for currents between 40 and  
2.500 A

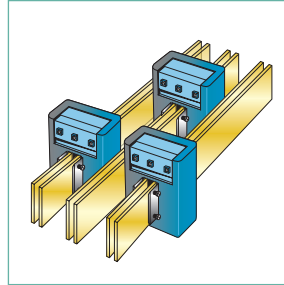

**BUSBAR PRIMARY**  
for currents between 750 and  
5.000 A

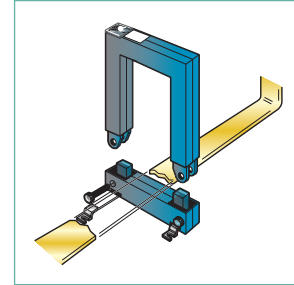

**SPLIT CORE PRIMARY**  
for easy connection to an existing  
installation using a busbar or  
cable primary

## ACCURACY LIMIT TABLES ACCORDING TO THE IEC 60044-1 STANDARD

It is important to always install the transformer in the right direction, especially on three-phase networks, so as not to invert the phase shift between the current and the voltage on one or more of the phases.

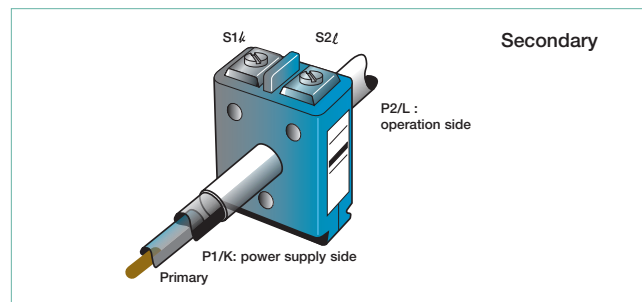
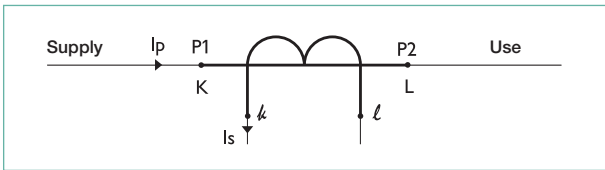

### Accuracy limit tables according to the IEC 60044-1 standard

Limit errors – Table 1

Class	± Error (in %) depending on In (in %)			
	5	20	100	120
<b>0.2</b>	0.75	0.35	0.20	0.20
<b>0.5</b>	1.50	0.75	0.50	0.50
<b>1</b>	3.00	1.50	1.00	1.00

Limit errors – Table 2

Class	± Error (in %) depending on In (in %)				
	1	5	20	100	120
<b>0.2 S</b>	0.75	0.35	0.20	0.20	0.20
<b>0.5 S</b>	1.50	0.75	0.50	0.50	0.50

## FINANCIAL IMPACT OF A CT'S ACCURACY CLASS

For a consumption of 12.000 MWh/year and a cost of 0.10 €/kWh

- CT class 1: ±120,000 kWh = ± € 12,000
- CT class 0.5: ±60,000 kWh = ± € 6,000
- CT class 0.2S: ±2,500 kWh = ± € 2,500

This calculation takes into account neither the class of the measuring instruments, nor losses occurring on the network cables.

### CT SAFETY RULES

You must never open the secondary circuit of a CT supplied on the primary. The very high voltage created may cause bodily harm or irreparable damage to the transformer. Before working on the secondary of a CT, it must be short-circuited.

When a CT is not in use (secondary open) the secondary must be short-circuited before powering up the system. See page 156, PRTC transformer short-circuiter.

# TCR RANGE

CTs designed for submetering.  
Accuracy class 0.5/1/3.

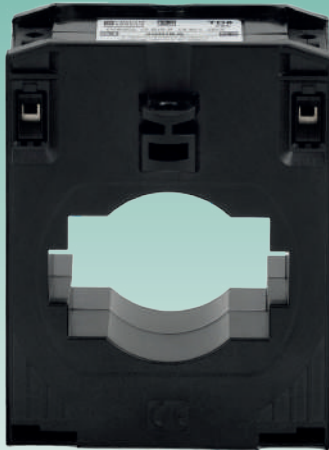

## GENERAL SPECIFICATIONS

- Reference standards:** IEC 61869-1, IEC 61869-2, UL94
- Maximum network voltage:** 720 Vac
- Dielectric test voltage:** 3 kV/50 Hz/1 min
- Frequency response:** 50/60 Hz
- Short-circuit thermal current (I<sub>th</sub>) :** 60 I<sub>n</sub> - 1 second
- Dynamic current (I<sub>dyn</sub>):** 2.5 I<sub>th</sub>
- Safety factor:** < 5
- Working temperature:** Thermal class B (130 °C)
- Plastic casing:** V0 self-extinguishing UL94
- Ingress protection on secondary terminals:** IP20
- Operating conditions: Temperature:** -10 °C to +50 °C  
Relative humidity < 90 %

## MOUNTING ACCESSORIES

Sealable terminal covers



DIN rail mounting



## USER SECTORS



Tertiary



Industry



Energy efficiency



Supplied with bar clamp fitting accessories



Plate mounting using removable screw-on clips



Outputs on split terminals enabling short-circuiting of the secondary current (M4 or cage for 4 mm<sup>2</sup> wire)



- Comprehensive range from 5 to 3.000 A
- All types of mounting
- Compact design

Model	Terminal cover	DIN rail
TCR20	P01340190	
TCR22-30	P01340191	P01340195
TCR28-40	P01340192	
TCR43-60	P01340193	
TCR63-80	P01340194	P01340196

## TCR WOUND PRIMARY

### TCR 10

25 x 25 mm aperture

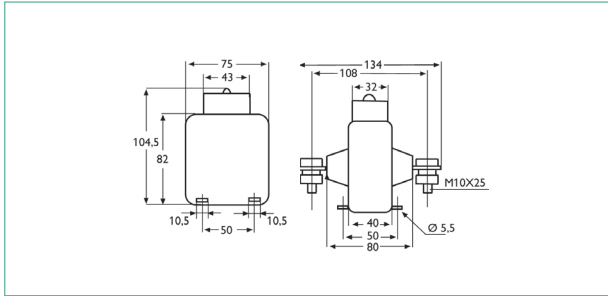

Primary	Power (VA) in class			Weight (kg)
	0.5	1	3	
5 A	15	20	30	0.70
10 A	15	20	30	0.70
50 A	15	20	30	0.80
60 A	15	20	30	0.80
75 A	15	20	30	0.75
125 A	15	20	30	0.70

### TCR 15

Primary: 16 mm<sup>2</sup> wire  
Secondary: 4 mm<sup>2</sup> wire

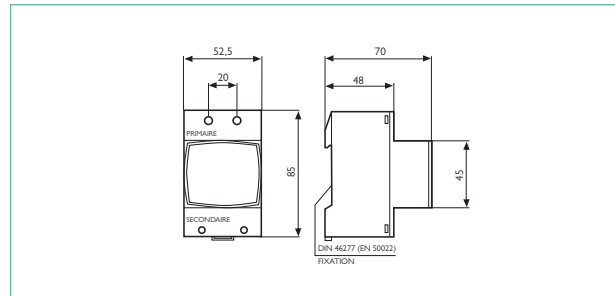

Primary	Power (VA) in class			Weight (kg)
	0.5	1	3	
5 A	2.5	5	7	0.28
10 A	2.5	5	7	0.28
15 A	2.5	5	7	0.28
20 A	2.5	5	7	0.28
25 A	2.5	5	7	0.28
30 A	2.5	5	7	0.28
50 A	2.5	5	7	0.28

## TO ORDER

Primary	Secondary 5 A
5A	1920 1507
10A	1920 1512
50A	1920 1519
60A	1920 1521
75A	1920 1523
125A	1920 1526

Primary	Secondary 5 A
5 A	1920 1707
10 A	1920 1712
15 A	1920 1714
20 A	1920 1715
25 A	1920 1716
30 A	1920 1717
50 A	1920 1719

## ASSOCIATED PRODUCTS



### PRTC

CT short-circuiter

Protection against hazards due to opening of the secondary circuit of a low voltage measurement CT.

page 138

## CABLE/BUSBAR PRIMARY

### TCR20

Cable Ø 20 mm

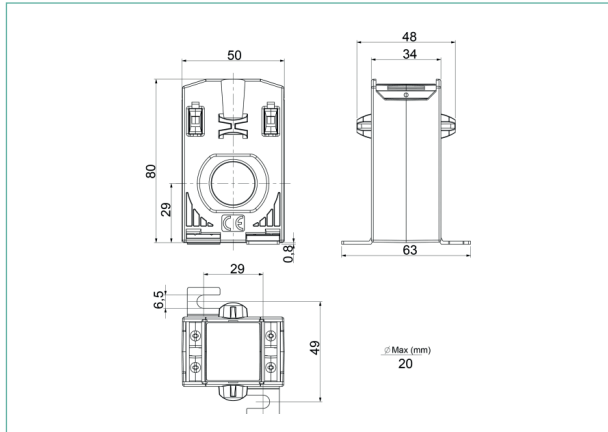

### TCR22-30

Cable Ø 22 mm

Bar : 25 x 10 | 30 x 10 | 20 x 12 (mm)

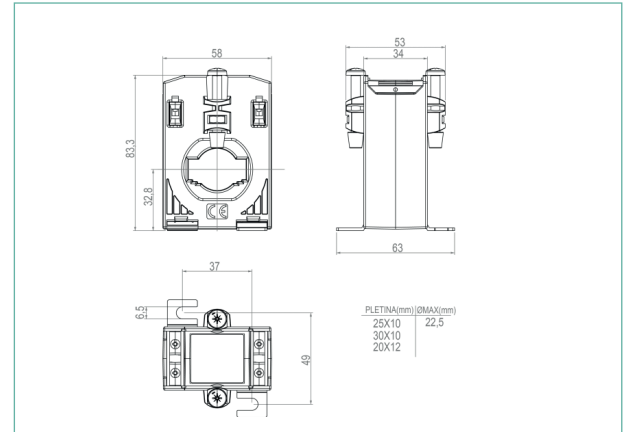

Primary	Power (VA) in class		
	0.5	1	3
40/5A	-	-	1.25
50/5A	-	1	1.5
60/5A	-	1.25	2.5
75/5A	-	1.5	3.75
100/5A	1.5	2.5	5
125/5A	2.5	3.75	5
150/5A	3.75	5	5
200/5A	5	7.5	7.5

Primary	Power (VA) in class		
	0.5	1	3
100/5A	-	-	1
125/5A	-	1	1.5
150/5A	1	1.5	2.5
200/5A	1.5	2.5	3.5
250/5A	2.5	3.5	5
300/5A	2.5	3.5	5
400/5A	2.5	3.5	5

## TO ORDER

Primary	Secondary 5 A
40/5A	P01340200
50/5A	P01340201
60/5A	P01340202
75/5A	P01340203
100/5A	P01340204
125/5A	P01340205
150/5A	P01340206
200/5A	P01340207

Primary	Secondary 5 A
100/5A	P01340208
125/5A	P01340209
150/5A	P01340210
200/5A	P01340211
250/5A	P01340212
300/5A	P01340213
400/5A	P01340214

## ASSOCIATED PRODUCTS



### PRTC

CT short-circuiter

Protection against hazards due to opening of the secondary circuit of a low-voltage measurement CT.

page 138

## CABLE/BUSBAR PRIMARY

### TCR28-40

Cable Ø 28 mm

Bar : 20 x 25 | 30 x 15 | 40 x 10

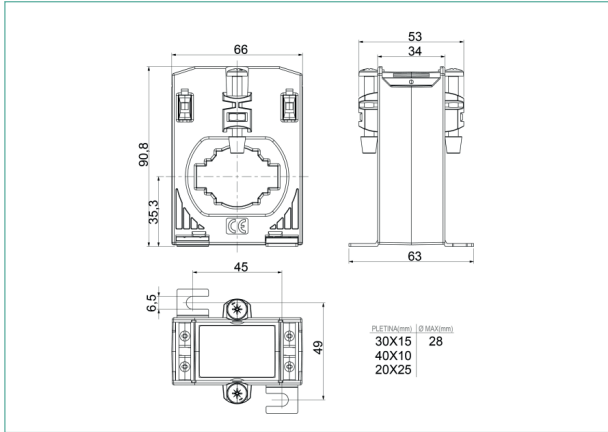

### TCR43-60

Cable Ø 43 mm

Bar : 50 x 30 | 60 x 12 | 12 x 45

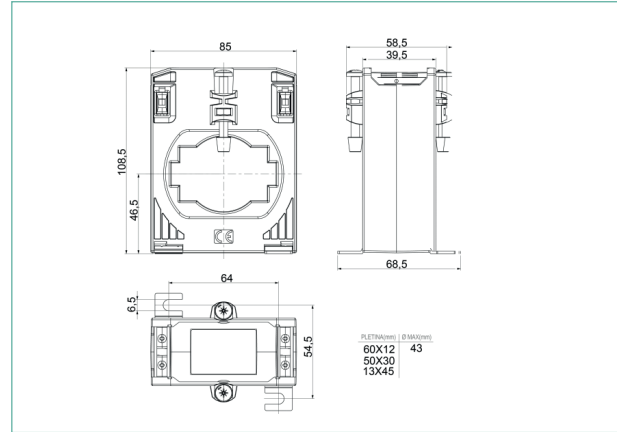

Power (VA) in class

Primary	0.5	1	3
150/5A	1	2.5	3.5
200/5A	1.5	3.5	5
250/5A	2.5	5	5
300/5A	2.5	5	5
400/5A	2.5	5	5
500/5A	5	7.5	7.5
600/5A	5	7.5	7.5

Power (VA) in class

Primary	0.5	1	3
400/5A	2.5	3.5	5
500/5A	2.5	5	5
600/5A	2.5	5	5
750/5A	2.5	5	5
800/5A	5	7.5	7.5
1000/5	5	7.5	10
1200/5	5	7.5	10

## TO ORDER

Primary	Secondary 5 A
150/5A	P01340215
200/5A	P01340216
250/5A	P01340217
300/5A	P01340218
400/5A	P01340219
500/5A	P01340220
600/5A	P01340221

Primary	Secondary 5 A
400/5A	P01340222
500/5A	P01340223
600/5A	P01340224
750/5A	P01340225
800/5A	P01340226
1000/5	P01340227
1200/5	P01340228

## ASSOCIATED PRODUCTS



### PRTC

CT short-circuiter

Protection against hazards due to opening of the secondary circuit of a low-voltage measurement CT.

page 138

### TCR63-80

Cable Ø 63 mm

Bar : 50 x 50 | 60 x 30 | 80 x 30

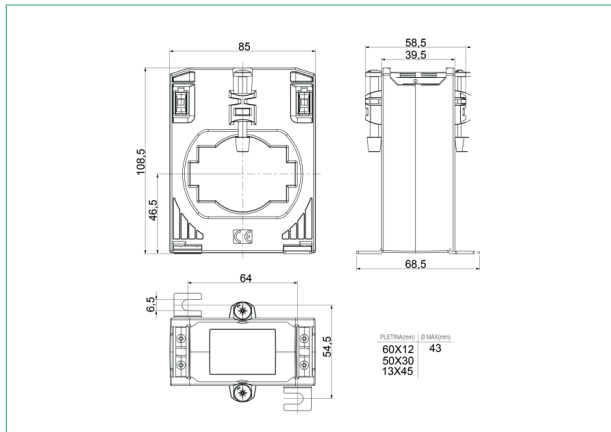

Power (VA) in class

Primary	0.5	1	3
1500/5	5	10	15
2000/5	5	10	15
2500/5	5	10	15
3000/5	5	10	15

### TO ORDER

Primary	Secondary 5 A
1500/5	P01340229
2000/5	P01340230
2500/5	P01340231
3000/5	P01340232

### ASSOCIATED PRODUCTS



#### PRTC

CT short-circuiter

Protection against hazards due to opening of the secondary circuit of a low-voltage measurement CT.

page 138



# JVS RANGE

CTs designed to supply electronic measuring instruments, power monitors, digital transducers, etc.

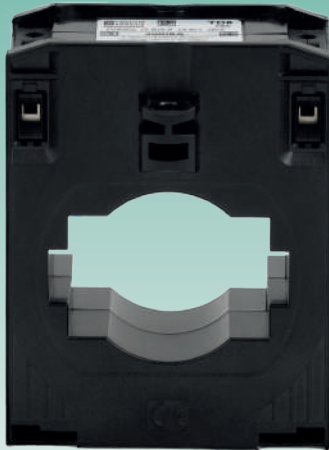

## GENERAL CHARACTERISTICS

**Reference standards:** IEC 61869-1, IEC 61869-2, UL94

**Maximum network voltage:** 720 Vac

**Dielectric test voltage:** 3 kV/50 Hz/1mn

**Frequency response:** 50/60 Hz

**Short-circuit thermal current (I<sub>th</sub>):** 60 I<sub>n</sub> - 1 second

**Dynamic current (I<sub>dyn</sub>):** 2,5 I<sub>th</sub>

**Safety factor:** < 5

**Working temperature:** Thermal class B (130 °C)

**Plastic casing:** V0 self-extinguishing UL94

**Ingress protection on secondary terminals:** IP20

**Operating conditions:**

**Temperature:** -5°C et + 40°C  
Relative humidity < 90 %

## USER SECTORS



Tertiary



Energy  
transmission  
& distribution



Naval  
applications



Supplied with mounting accessories for clamping onto a bar.



Mounting at the bottom of the cabinet using removable screw-on brackets.



Outputs on split terminals allowing the secondary to be short-circuited (M4 or cage for 4 mm<sup>2</sup> wire).



- Complete range from 150 to 1000A
- Accuracy class: 0.2s
- Compact size

Model	Terminal cover	DIN rail
JVS 28-40	P01340192	P01340195
JVS 43-60	P01340193	P01340196

## MOUNTING ACCESSORIES

Sealable terminal cover



DIN rail mounting



## PRIMARY CABLE / BAR

### JVS 28-40

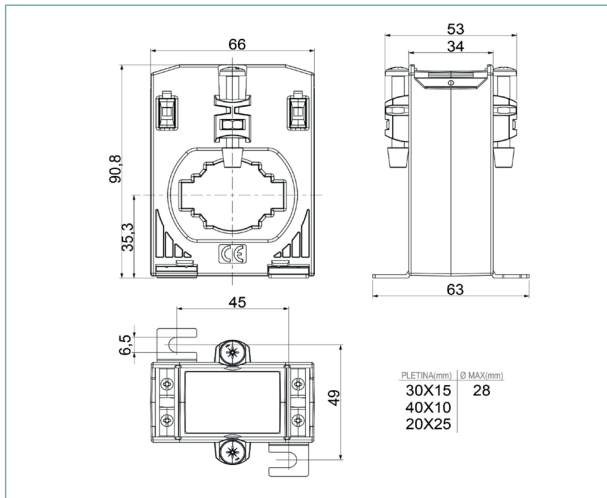

Primary	Power (VA) Class 0.2 S
150 A	0,5
200 A	1
250 A	1,5
300 A	2,5
400 A	2,5
500 A	3,5

### JVS 43-60

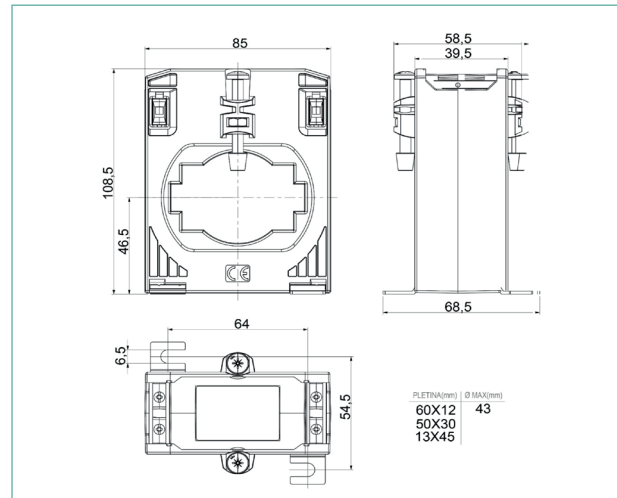

Primary	Power (VA) Class 0.2 S
600 A	2
750 A	2
800 A	2
1000 A	3,5

## TO ORDER

Primary	Secondary 5 A
150 A	P01340500
200 A	P01340501
250 A	P01340502
300 A	P01340503
400 A	P01340504
500 A	P01340505

Primary	Secondary 5 A
600 A	P01340506
750 A	P01340507
800 A	P01340508
1000 A	P01340509

## ASSOCIATED PRODUCTS



### PRTC

CT short-circuiter Protection against hazards due to opening of the secondary circuit of a low, voltage measurement CT.

page 138

# TCRO RANGE

CTs designed for submetering.  
Accuracy class 0.5/1/3



## GENERAL SPECIFICATIONS

- Reference standards:** IEC 61869-2, UL94
- Max. grid voltage:** 720 Vac
- Dielectric test voltage:** 3 kV/50 Hz/1 min
- Frequency response:** 50/60 Hz
- Thermal short-circuit current (I<sub>th</sub>) :** 60 I<sub>n</sub> - 1 second
- Dynamic current (I<sub>dyn</sub>):** 2.5 I<sub>th</sub>
- Safety factor:** 10
- Working temperature:** Thermal class B (130 °C)
- Plastic casing:** V0 Self-extinguishing UL94
- Ingress protection on secondary terminals:** IP20
- Operating conditions:** Temperature: -10 °C to +50 °C  
Relative humidity < 90 %
- DIN rail mounting:** Yes

## USER SECTORS



Tertiary



Industry



Energy  
efficiency



Naval  
applications



Plate mounting with screw-on movable clips or DIN rail mounting



Sealable cover



Button for instant opening



- New opening system for easier implementation
- Wide choice of aperture sizes

## STANDARD MOUNTING ACCESSORIES

Model	Plate-mounting fitting	Busbar clamps
TCRO 2030	■	■
TCRO 6080	■	■
TCRO 8080	■	■
TCRO 80120	■	■
TCRO 80160	■	■

## TCRO RANGE

### TCRO 2030

Bar : 20 x 30 mm

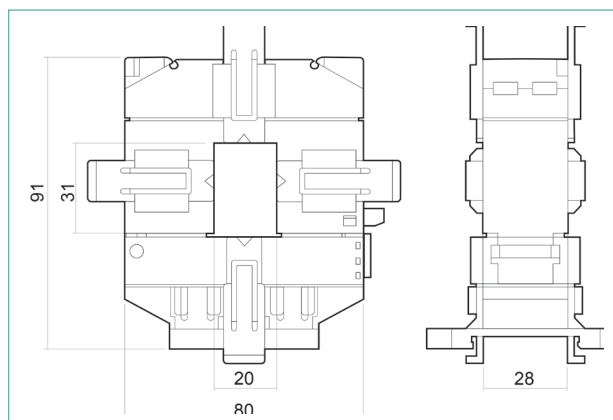

Primary	Power VA in Class		
	0.5	1	3
100/5A	-	-	1
150/5A	-	-	1
200/5A	-	-	2
250/5A	-	1	2
400/5A	1	2.5	4

### TCRO 6080

Bar : 60 x 80 mm

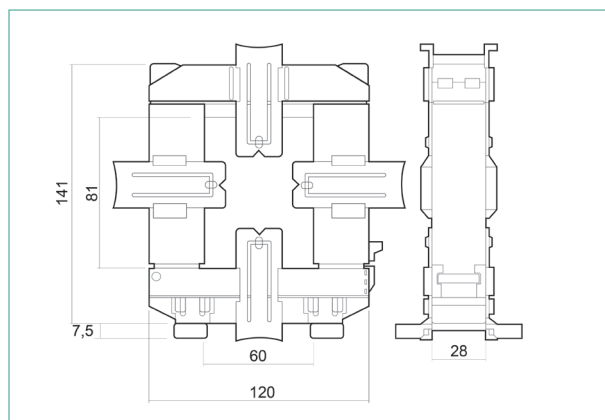

Primary	Power VA in Class		
	0.5	1	3
400/5A	1	1.5	3
500/5A	2	5	7.5
600/5A	2	5	8
800/5A	3	6	10
1000/5	5	8	15

## TO ORDER

Primary	Secondary 5 A
100/5A	P01340300
150/5A	P01340301
200/5A	P01340302
250/5A	P01340303
400/5A	P01340304

Primary	Secondary 5 A
400/5A	P01340305
500/5A	P01340306
600/5A	P01340307
800/5A	P01340308
1000/5	P01340309

## ASSOCIATED PRODUCTS



### PRTC

CT short-circuiter

Protection against hazards due to opening of the secondary circuit of a low-voltage measurement CT.

page 138

METERS AND  
POWER MONITORS

NETWORK MONITORING  
FROM LV TO HV

CURRENT TRANSFORMERS  
AND SHUNTS

TRANSDUCERS

PANEL METERS AND  
SYNCHROCOUPLER

AUXILIARY RELAYS

CIVILIAN AND MILITARY  
NAVAL APPLICATIONS

SERVICES AND TRAINING

## TCRO RANGE

### TCRO 80120

Bar : 120 x 80

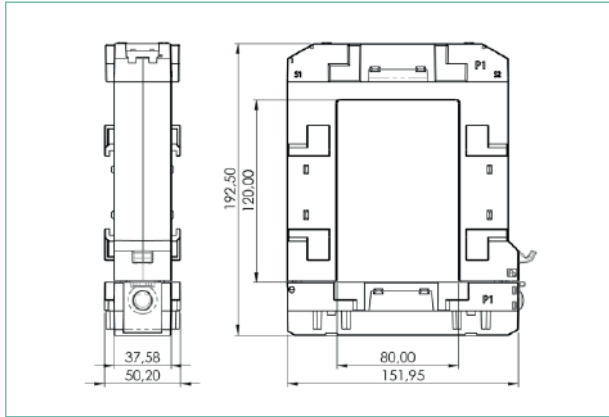

### TCRO 80160

Bar : 160 x 80

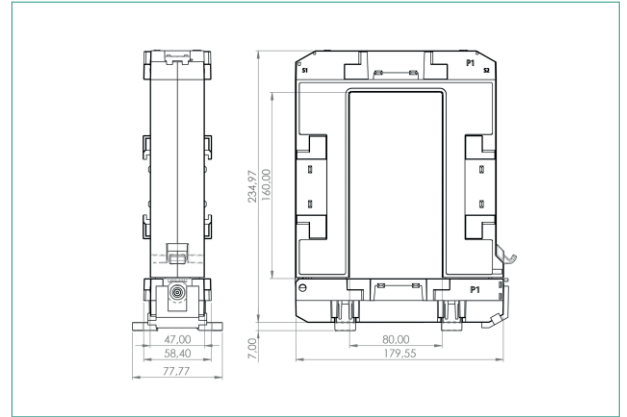

Power VA in Class

Primary	0.5	1	3
<b>500/5A</b>	-	4	12
<b>800/5A</b>	3	7	18
<b>1000/5A</b>	5	9	20
<b>1200/5A</b>	6	11	24
<b>1500/5A</b>	8	17	30

Power VA in Class

Primary	0.5	1	3
<b>1500/5A</b>	15	20	25
<b>2000/5A</b>	15	20	25
<b>2500/5A</b>	15	20	25
<b>3000/5A</b>	15	20	25

## TO ORDER

Primary	Secondary 5 A
<b>500/5A</b>	P01340310
<b>800/5A</b>	P01340311
<b>1000/5A</b>	P01340312
<b>1200/5A</b>	P01340313
<b>1500/5A</b>	P01340314

Primary	Secondary 5 A
<b>1500/5A</b>	P01340315
<b>2000/5A</b>	P01340316
<b>2500/5A</b>	P01340317
<b>3000/5A</b>	P01340318

## ASSOCIATED PRODUCTS



### PRTC

CT short-circuiter

Protection against hazards due to opening of the secondary circuit of a low-voltage measurement CT.

page 138



# TC CLIP RANGE

Compact CT for integration on electrical installations without disconnecting the power cables.

## USER SECTORS



Tertiary



Industry



Energy efficiency



Reinforced hinge

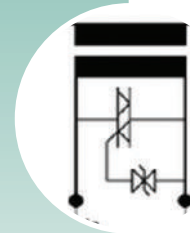

Built-in short-circuiting switch



- Quick, practical implementation without cutting off the power supply
- Compact design
- Built-in short-circuiting switch
- Primary from 60 to 600 A
- High VA
- Reinforced hinge

## GENERAL SPECIFICATIONS

**Max. grid voltage :** 720 Vac

**Dielectric test voltage :** 3 kV 50 Hz 1 min

**Secondary current :** 1 A

**Power :** up to 1 VA

**Frequency:** 50 / 60 Hz

**Operating temperature:** -20 °C to +55 °C

**Accuracy class:** up to 0.5 %

**Reference standard:** IEC 61869-2

The **TC CLIP** models are compatible with all the measuring products on the market with 1 A CT input. In particular, they are compatible with the ENERIUM power monitors and ULYS submeters from CHAUVIN ARNOUX ENERGY®.

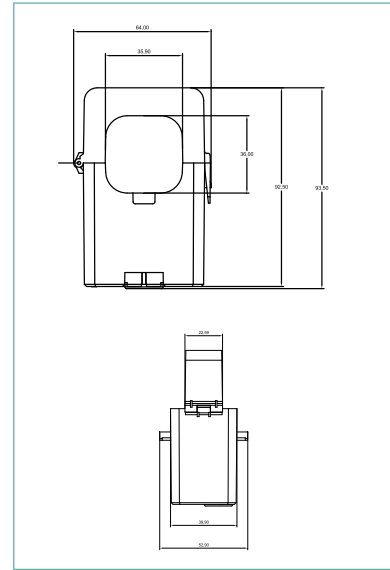
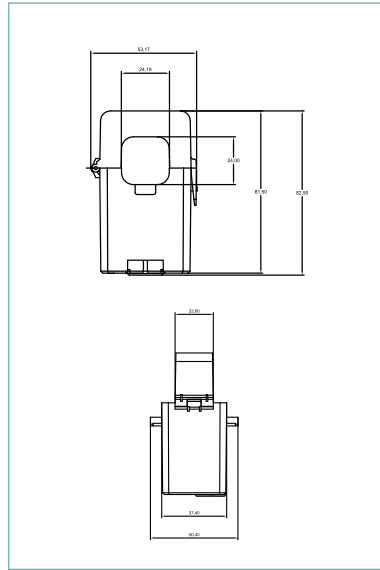
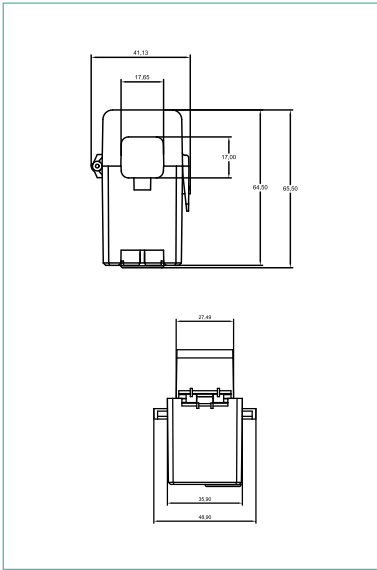

	TCC16	TCC24	TCC24	TCC36	TCC36
<b>Primary</b>	60 A	100 A	250 A	400 A	600 A
<b>Secondary</b>			1A		
<b>Power (VA)</b>	0.2	0.2	0.5	1	1
<b>Accuracy class</b>	3	1	1	0.5	0.5
<b>Diameter</b>	16	24		36	
<b>Dimensions (mm)</b>	64 x 33 x 34.4	74.5 x 45 x 34	74.5 x 45 x 34	91 x 57 x 40.5	91 x 57 x 40.5
<b>Weight (g)</b>	127	188	188	262	262

## TO ORDER

Model	Reference
<b>TCC16 60/1A</b>	P01340400
<b>TCC24 100/1A</b>	P01340402
<b>TCC24 250/1A</b>	P01340404
<b>TCC36 400/1A</b>	P01340406
<b>TCC36 600/1A</b>	P01340408

Pack of 3 TC CLIP	Reference
<b>Pack 3 TCC16 60/1A</b>	P01340401
<b>Pack 3 TCC24 100/1A</b>	P01340403
<b>Pack 3 TCC24 250/1A</b>	P01340405
<b>Pack 3 TCC36 400/1A</b>	P01340407
<b>Pack 3 TCC36 600/1A</b>	P01340409

# SINGLE-PHASE CORE CT RANGE

CTs designed to supply analog or digital measurement instruments. Accuracy class 0.5/1/3.

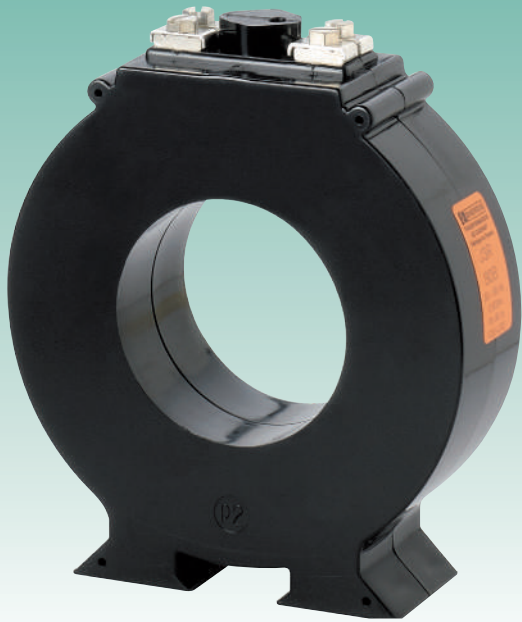

## General specifications

- Reference standards:** EN 60044-1 (ex IEC 185)
- Maximum network voltage:** 720 Vac
- Dielectric test voltage:** 3 kV/50 Hz/1 min
- Frequency response:** 50/60 Hz
- Short-circuit thermal current (Ith):** JVO, JVP: 80 In  
JVR 86: 60 In
- Dynamic current (Idyn):** 2.5 Ith
- Safety factor:** 5 in Class 1
- Operating conditions:** Temperature: -5°C to +50°C  
Relative humidity: 93% at 40°C
- Protection:** Protection rating: IP 50  
(with terminal cover supplied)  
Dry winding with self-extinguishing ABS  
coZvOeOriMng (UL 94 VO)

## MOUNTING ACCESSORIES

Model	1 CT mounting rail	2 CT mounting rail	3 CT mounting rail
JVR	ACCE 7652	ACCE 7653	ACCE 7655
J3R 80 B	ACCE 7640		

## USER SECTORS



Industry



Energy transmission & distribution



Sealable cover M5 terminals with 2 grooves for dual connection on secondary

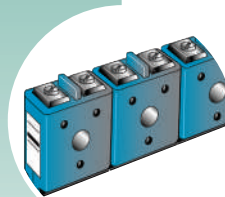

Mounting on symmetrical rail (except for JVP) or plate mounting in cabinet



- Complete range: primary from 1 to 3,000 A and 5 A or 1 A secondary
- Totally adaptable range for specific requirements (primary, secondary, power class, frequency)

The following CTs are still available. Please contact Chauvin Arnoux Energy:

- JVR 64 and JVR 75
- JVO 12-46 / JVO 18-51 / JVO 21-64 / JVO 21-75 / JVO 32-75 / JVO 36-75 and JVO 25 CR
- JVO 32 CR and JVP 624

## 3CT MOUNTING

Dimensions

Model	A	B	C	D	E	F	G
JVP 1025	344	115	45	252	138	137	22
JVP 1045	404	135	45	312	178	137	42

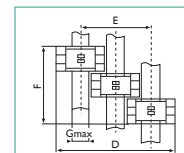
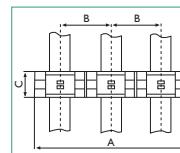

**JVR 86**

Ø M8/M10 > 75 A  
Weight : 1.2 kg

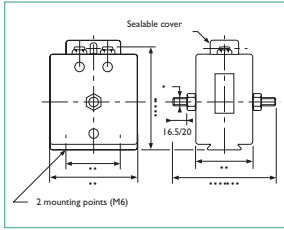

Power (VA) in class

Primary	1	3
5 A	20	30
10 A	20	30
15 A	20	30
20 A	20	30
25 A	20	30
30 A	20	30
40 A	20	30
50 A	20	30
60 A	20	30
75 A	20	30
100 A	20	30
125 A	20	30
150 A	20	30
200 A	20	30

**J3R 80 B**

Cable Ø 66 mm  
Weight : 1.6 kg

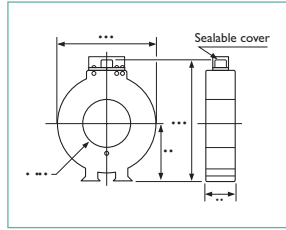

Power (VA) in class

Primary	0.5	1	3
200 A		5	10
250 A		5	10
300 A	5	10	15
400 A	10	20	25
500 A	15	20	25
600 A	15	20	25
750 A	15	20	25
800 A	15	20	25
1000 A	15	20	25
1250 A	15	20	25
1500 A	15	20	25

**JVP 1025**

Bar : 100 x 20 mm  
Weight : 2 kg

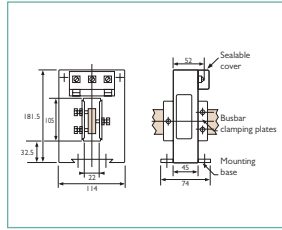

Power (VA) in class

Primary	1	3
200 A		5
250 A		5
300 A	10	20
400 A	5	30
500 A	15	15
600 A	15	15
750 A	20	20
800 A	20	30
1000 A	30	30
1250 A	30	30
1500 A	30	30
2000 A	30	30
2500 A	30	30
3000 A	30	30

**JVP 1045**

Bar : 100 x 40 mm  
Weight : 2.5 kg

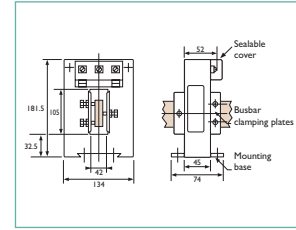

Power (VA) in class

Primary	1	3
300 A	5	5
400 A	5	10
500 A	10	15
600 A	15	15
750 A	20	20
800 A	20	20
1000 A	30	30
1250 A	30	30
1500 A	30	30
2000 A	30	30
2500 A	30	30
3000 A	30	30

**TO ORDER**

Primary	Secondary 5A
5 A	JVRC 8742
10 A	JVRC 8743
15 A	JVRC 8744
20 A	JVRC 8745
25 A	JVRC 8746
30 A	JVRC 8747
40 A	JVRC 8748
50 A	JVRC 8749
60 A	JVRC 8750
75 A	JVRC 8751
100 A	JVRC 8752
125 A	JVRC 8753
150 A	JVRC 8754
200 A	JVRC 8755
Sealable cover	ACCE 7668

Primary	Secondary 5 A
200 A	J3RC 7514
250 A	J3RC 7524
300 A	J3RC 7525
400 A	J3RC 7528
500 A	J3RC 7527
600 A	J3RC 7529
750 A	J3RC 7526
800 A	J3RC 7531
1000 A	J3RC 7530
1250 A	J3RC 7532
1500 A	J3RC 7533
Sealable cover	ACCE 7671

Primary	Secondary 5 A
200 A	JVPT 8890
250 A	JVPT 8891
300 A	JVPT 8892
400 A	JVPT 8893
500 A	JVPT 8896
600 A	JVPT 8897
750 A	JVPT 8898
800 A	JVPT 8895
1000 A	JVPT 8899
1250 A	JVPT 8900
1500 A	JVPT 8901
2000 A	JVPT 8902
2500 A	JVPT 8921
3000 A	JVPT 8922
Mounting plate (base)	ACCE 7669
Sealable cover	ACCE 7672

Primary	Secondary 5 A
300 A	JVPU 8906
400 A	JVPU 8918
500 A	JVPU 8907
600 A	JVPU 8908
750 A	JVPU 8909
800 A	JVPU 8919
1000 A	JVPU 8910
1250 A	JVPU 8911
1500 A	JVPU 8912
2000 A	JVPU 8913
2500 A	JVPU 8920
3000 A	JVPU 8914
Mounting plate (base)	ACCE 7669
Sealable cover	ACCE 7672

**CUSTOMIZED PRODUCT**

	Model	Primary	Secondary	Class	Power	Frequency
	JVR 86 J3R 80 B JVP 1025 JVP 1045					
Example	JVR 86	200 A	1 A	0.5	10 VA	60 Hz

**ASSOCIATED PRODUCTS**

**Mounting accessories**

Mounting rails  
1 CTn 2 CTs, 3 CTs.  
page 128



**PRTC**

CT short-circuiter  
Protection against hazards due to opening of the secondary circuit of a low, voltage measurement CT.  
page 138



# JVP 1045 B

Busbar primary 100 x 40 mm

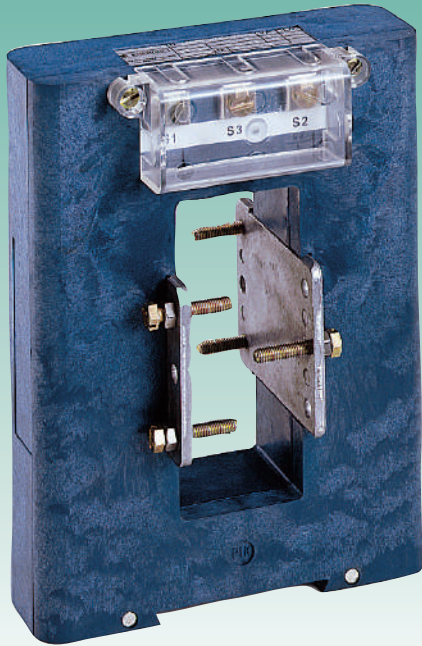

- Delivered with sealable protective cover for the secondary. Simple M5 terminals
- Direct mounting on primary busbar by means of plate and tightening screw or panel mounting with mounting plate

## GENERAL SPECIFICATIONS

**Reference standards:** EN 60044-1 (ex-IEC 185) and NFC 42-502

**Maximum network voltage:** 720 Vac

**Dielectric test voltage:** 3 kV/50 Hz/1 min

**Frequency response:** 50/60 Hz

**Thermal short-circuit current (I<sub>th</sub>):** 80 In

**Dynamic current (I<sub>dyn</sub>):** 2.5 I<sub>th</sub>

**Safety factor:** 10 in class 0.5

Except \* SF = 6.4/10.5 and \*\*SF = 4.7/8.2

**Operating conditions:**

Temperature: -20°C to +60°C

Relative humidity: 93% at 40°C

**Protection:**

- Protection rating: IP 50
- Dry winding in self-extinguishing ABS envelope (UL 94 VO)

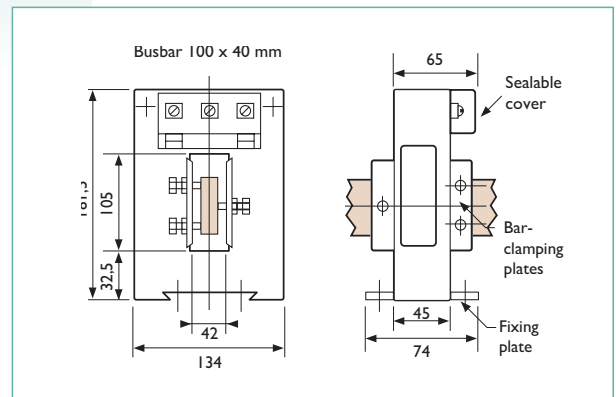

## TO ORDER

Primary	Power (VA) in class 0.5		Weight (kg)
	7.5	15	
500 A	JVPA 7569		2.50
1000 A	JVPA 7573		2.50
2000 A	JVPA 7576		2.50
500-1000 A*	JVPA 7589	JVPA 7585	2.50
1000-2000 A*	JVPA 7590	JVPA 7588	2.50

# JVO 40-100

Cable primary Ø 42 mm



- Delivered with sealable terminal cover for the secondary. M5 terminals with two grooves for double connection
- Mounting on symmetrical mounting rail or plate mounting

## GENERAL SPECIFICATIONS

**Reference standards:** EN 60044-1 (ex-IEC185) and NFC 42-502

**Maximum network voltage:** 720 Vac

**Dielectric test voltage:** 3 kV/50 Hz/1 min

**Frequency response:** 50/60 Hz

**Thermal short-circuit current (Ith):** 80 In

**Dynamic current (Idyn):** 2.5 Ith

**Safety factor:** 110 in class 0.5

Except \* SF = 6.4/10.5 and \*\*SF = 4.7/8.2

**Operating conditions:**

Temperature: -5 °C to +50 °C

Relative humidity: 93 % at 40 °C

**Protection:**

- Protection rating: IP 50
- Dry winding in self-extinguishing ABS envelope (UL 94 VO)

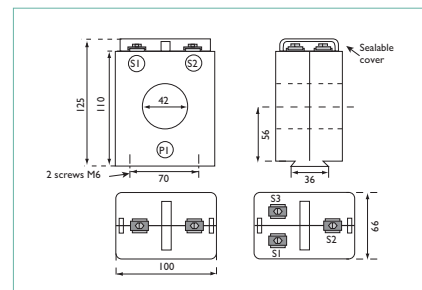

## TO ORDER

Primary	Power (VA) in class 0.5			Weight (kg)
	Secondary 2.5 A	Secondary 5 A	Secondary 5 A	
200 A	JVON 7103		JVON 7100	0.97
500 A			JVON 7101	0.97
200-500 A		JVON 7104	JVON 7102	0.97
1-CT mounting rail		ACCE 7679		
2-CT mounting rail		ACCE 7680		
3-CT mounting rail		ACCE 7681		

# JVO 40-100 S

## BI-RATING

Cable primary Ø 40 mm



### GENERAL SPECIFICATIONS

- Cable primary:** JVO 40-100 S bi Rating : Ø 40 mm
- Transformation ratio:** JVO 40-100 S bi Rating : 200-500/5 A
- Accuracy class:** JVO 40-100 S : 0.2s
- Precision power:** JVO 40-100 S : 7.5 VA
- Highest network voltage:** JVO 40-100 S : 720 Vac
- Rated frequency:** JVO 40-100 S : 50/60 Hz
- Rated short-circuit thermal current (Ith):**  
20 kA for 1 s
- Rated dynamic current (Idyn):** 2.5 Ith
- Safety factor:** SF = 3 (200/5 A); SF = 6 (500/5 A)
- Rated thermal current:** 1.2 Ipn
- Operating temperature:** -25°C to +40°C
- Type of casing:** Self-extinguishing thermoplastic (UL94V0)
- Protection:** IP30
- Mechanical shock resistance:** IK7
- Rated withstand voltage:** 3 kV (RMS value) at 50 Hz for 1 minute
- Rated lightning impulse withstand voltage:**  
8 kV (peak value) – Wave 1.2/50 µs
- Insulation class:** E (heating limit: 75 K)
- Weight:** 1.1 kg



- Class 0.2s according to IEC 60044-1
- Particularly suitable for ENEDIS-qualified bi-rating electronic meters

### DIMENSIONS

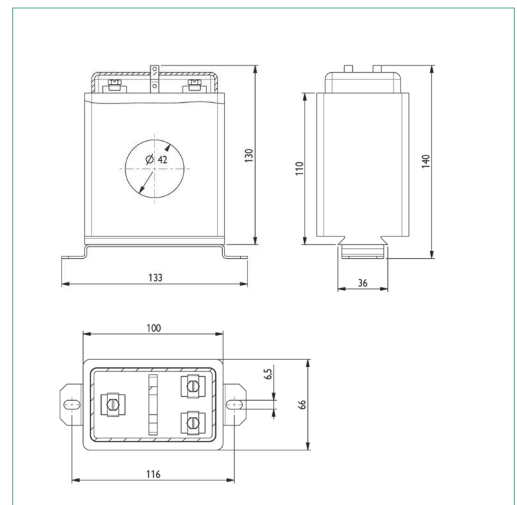

### TO ORDER

Model	Reference
JVO 40-100 S bi-rating	P01379512

# JVO 90-160 S

## TRI-RATING

Cable primary Ø 90 mm

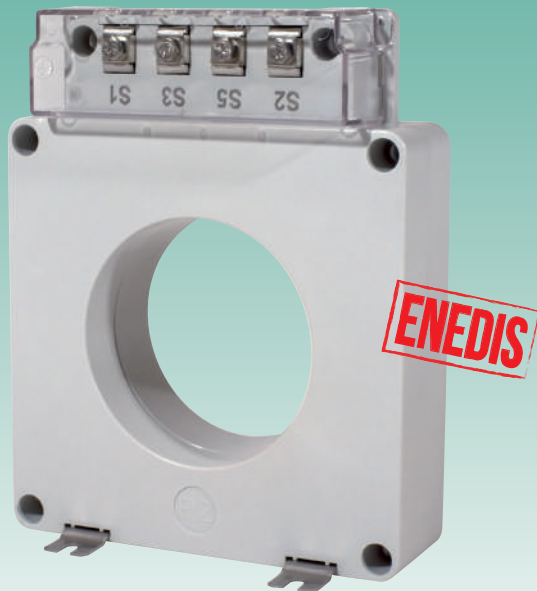

### GENERAL SPECIFICATIONS

- Cable primary:** Ø 90 mm
- Transformation ratio:** J500 - 1.000 - 2.000 / 5 A
- Accuracy class:** 0.2s
- Precision power:** 7.5 VA
- Highest network voltage:** 720 Vac
- Rated frequency:** 50/60 Hz
- Rated short-circuit thermal current (I<sub>th</sub>):** 30 kA for 1 s
- Rated dynamic current (I<sub>dyn</sub>):** 2.5 I<sub>th</sub>
- Safety factor:** SF = 4 (500/5 A);  
SF = 6 (1 000/5 A);  
SF = 9 (2 000/5 A)
- Rated thermal current:** 1.2 I<sub>pn</sub>
- Operating temperature:** -25°C to +40°C
- Type of casing:** Self-extinguishing thermoplastic (UL94V0)
- Protection:** IP30
- Mechanical shock resistance:** IK7
- Rated withstand voltage:** 3 kV (RMS value) at 50 Hz for 1 minute
- Rated lightning impulse withstand voltage:** 8 kV (peak value) – Wave 1.2/50 µs
- Insulation class:** E (heating limit: 75 K)
- Weight:** 1.9 kg



- Class 0.2s according to IEC 60044-1
- Particularly suitable for ENEDIS-qualified tri-rating electronic meters

### DIMENSIONS

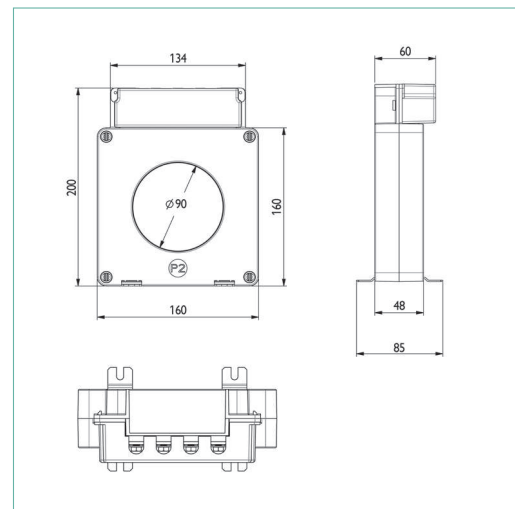

### TO ORDER

Model	Reference
JVO 90-160 S tri-rating	P01379513

METERS AND  
POWER MONITORS

NETWORK MONITORING  
FROM LV TO HV

CURRENT TRANSFORMERS  
AND SHUNTS

TRANSDUCERS

PANEL METERS AND  
SYNCHROCOUPLER

AUXILIARY RELAYS

CIVILIAN AND MILITARY  
NAVAL APPLICATIONS

SERVICES AND TRAINING

# JVP 1145 S

## TRI-RATING

Cable/busbar primary



### GENERAL SPECIFICATIONS

**Cable primary:** Busbar: 63 x 12 mm or 100 x 12 mm

**Cable:** Ø 40 mm

**Transformation ratio:** 500 – 1.000 – 2.000 / 5 A

**Accuracy class:** 0.2s

**Precision power:** 7.5 VA

**Highest network voltage:** 720 Vac

**Rated frequency:** 50/60 Hz

**Rated short-circuit thermal current (I<sub>th</sub>):** 30 kA for 1 s

**Rated dynamic current (I<sub>dyn</sub>):** 2.5 I<sub>th</sub>

**Safety factor:** SF = 3 (500/5 A);  
SF = 4 (1000/5 A);  
SF = 6 (2000/5 A)

**Rated thermal current:** 1.2 I<sub>pn</sub>

**Operating temperature:** -25°C to +40°C

**Type of casing:** Self-extinguishing thermoplastic (UL94V0)

**Protection:** IP30

**Mechanical shock resistance:** IK7

**Rated withstand voltage:** 3 kV (RMS value) at 50 Hz for 1 minute

**Rated lightning impulse withstand voltage:**

8 kV (peak value) – Wave 1.2/50 µs

**Insulation class:** E (heating limit: 75 K)

**Weight:** 1.7 kg



- Class 0.2s according to IEC 60044-1
- Particularly suitable for ENEDIS-qualified tri-rating electronic meters

### DIMENSIONS

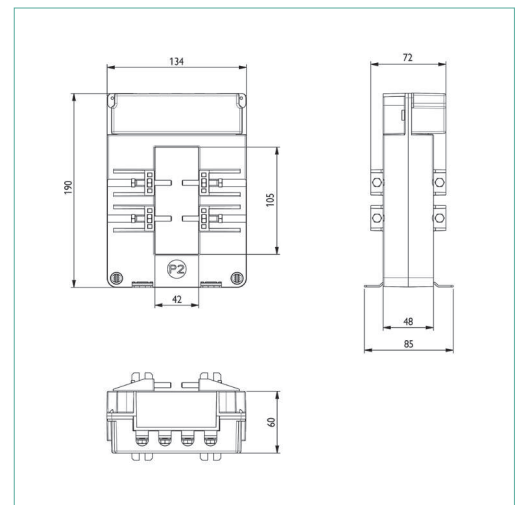

### TO ORDER

Model	Reference
JVP 1145 S tri Rating	P01379510

# THREE-PHASE PLATE-MOUNTED CT RANGE

## TRI 500

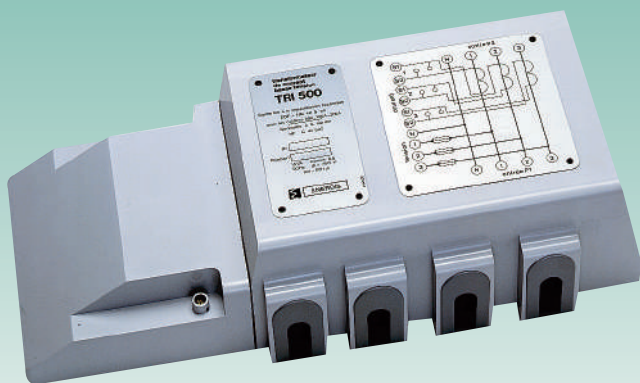

### GENERAL SPECIFICATIONS

- Maximum network voltage: 720 Vac
- Dielectric test voltage: 3 kV - 50 Hz - 1mn
- Rated short-circuit thermal current (I<sub>th</sub>): 80 In
- Lightning impulse withstand voltage 1.2/50  $\mu$ s: 8 kV
- Frequency response: 50 Hz
- Primary via cable clamp: conductors from 50 to 240 mm<sup>2</sup>

Primary	Power (VA) Class 0.5	Weight (kg)
50 A	15	7.50
100 A	15	7.50
150 A	15	7.50
200 A	15	7.50
300 A	15	7.50
500 A	15	7.50

### USER SECTORS



Industry



Energy  
transmission  
& distribution



- Compliant with NF-C-42-502 standard and CEI 60044-1
- Designed for three-phase LV metering

### DIMENSIONS

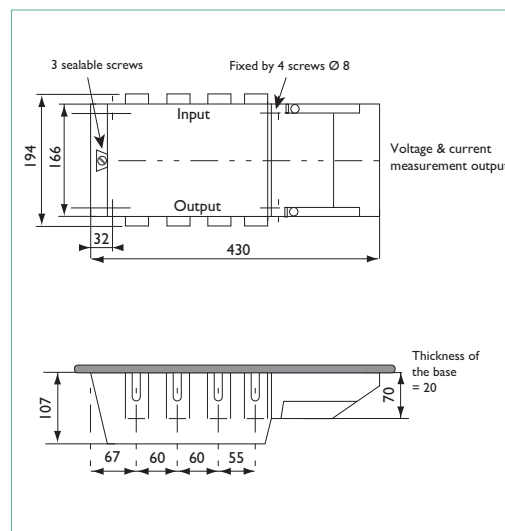

### TO ORDER

Model	Reference
50 A	TRI5 7823
100 A	TRI5 7825
150 A	TRI5 7826
200 A	TRI5 7827
300 A	TRI5 7828
500 A	TRI5 7831

75/5, 250/5, 400/5 and 600/5 also available. Please contact us.

METERS AND  
POWER MONITORS

NETWORK MONITORING  
FROM LV TO HV

CURRENT TRANSFORMERS  
AND SHUNTS

TRANSDUCERS

PANEL METERS AND  
SYNCHROCOUPLER

AUXILIARY RELAYS

CIVILIAN AND MILITARY  
NAVAL APPLICATIONS

SERVICES AND TRAINING

# TRI 700

Transformers for tariff metering  
ERDF application



- Class 0.2s according to IEC 60044-1
- Choice of primary conductor type: copper or aluminium
- Built-in short-circuiting switch

## ENCOMBREMENT

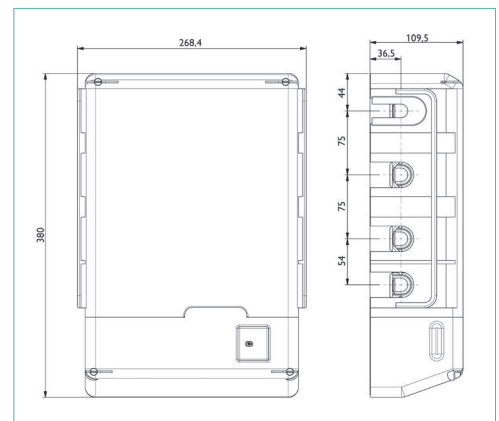

## TO ORDER

Model	Reference
TRI 700 tri-rating	P01379514
TRI 700 S bi-rating 50 - 100 / 5 A	P01379515
TRI 700 S bi-rating 100 - 200 / 5 A	P01379516
TRI 700 S bi-rating 200 - 500 / 5 A	P01379517

## GENERAL SPECIFICATIONS

**Primary via cable clamp:** Conductor cross-section from 50 mm<sup>2</sup> to 240 mm<sup>2</sup>

**Transformation ratio:**

TRI700S bi-rating model 50 A - 100 A / 5 A  
 TRI700S bi-rating model 100 A - 200 A / 5 A  
 TRI700S bi-rating model 200 A - 500 A / 5 A  
 TRI700 tri-rating model 100 A - 200 A - 500 A / 5 A

**Accuracy class:** Bi-rating model 0.2s; tri-rating model: 0.5

**Precision power:** Bi-rating model: 7.5 VA; tri-rating model: 3.75 VA

**Maximum network voltage:** Bi-rating / tri-rating model: 720 Vac

**Rated frequency:** Bi-rating / tri-rating model: 50/60 Hz

**Rated thermal short-circuit current (I<sub>th</sub>):** Bi-rating / tri-rating model: 80 I<sub>pn</sub> with a maximum of 20 kA for 1 s

**Rated dynamic current (I<sub>dyn</sub>):** Bi-rating / tri-rating model: 2.5 I<sub>th</sub>

**Safety factor:**

TRI700S 50 - 100 / 5 A: SF = 2.3 (50 A); SF = 4.2 (100 A)  
 TRI700S 100-200/5 A: SF = 2.3 (100 A); SF = 4.2 (200 A)

TRI700S 200 - 500 / 5 A: SF = 2.3 (200 A); SF = 5 (500 A)

TRI700 100 - 200 - 500 / 5 A: SF = 4 (100 A);

SF = 7 (200 A); SF = 10 (500 A)

**Rated thermal current:** Bi-rating / tri-rating model: 1.2 I<sub>pn</sub>

**Operating temperature:**

Bi-rating / tri-rating model: -25°C to +40°C

**Type of casing: Bi-rating / tri-rating model:**

Self-extinguishing thermoplastic (UL94V0)

**Protection rating:** With additional cover: IP40

**Mechanical shock resistance:** Bi-rating / tri-rating model: (IK7)

**Rated withstand voltage: Bi-rating / tri-rating model:** 3 kV (RMS value) at 50 Hz for 1 minute

**Lightning impulse withstand voltage:** Bi-rating / tri-rating model: (8 kV) (peak value) – Wave 1.2/50 μs

**Insulation class: Bi-rating / tri-rating model:** E (heating limit: 75 K)

**Weight:** Bi-rating / tri-rating model: 9 kg

# CURRENT SUMMATION JVM 15

CT designed for adding or subtracting instantaneous values from the secondaries of 2 or 3 current transformers.

Used to supply measuring or metering instruments on installations with several feeders or feeds.



## GENERAL SPECIFICATIONS

- Reference standard:** EN 60044-1 (ex IEC 185)
- Maximum network voltage:** 720 Vac
- Dielectric test voltage:** 3 kV/50 Hz/1 min
- Frequency response:** 50/60 Hz
- Short-circuit thermal current (I<sub>th</sub>):** 80 I<sub>n</sub> - 1 second
- Dynamic current (I<sub>dyn</sub>):** 2.5 I<sub>th</sub>
- Safety factor:** < 5
- Internal power:** 4 VA
- Operating conditions:** Temperature: -5°C to +60°C  
Relative humidity: 93% at 40°C
- Protection:** Protection rating:  
IP 40 (module casing) and IP 10 (terminals)  
Dry winding with self-extinguishing ABS covering (UL 94 VO)

## CABINET ACCESSORIES

Pour Model	Power (VA) in class			Weight (kg)
	0.5	1	3	
JVM 15	1 CT slide rail mounting ACCE 7652	2 CT slide rail mounting ACCE 7653	3 CT slide rail mounting ACCE 7655	
<b>5 + 5 A</b>	15	20	30	1.20
<b>5 + 5 + 5 A</b>	15	20	30	1.20

## USER SECTORS



Tertiary



Industry



Energy efficiency



Sealable cover. Terminal connections: M5; secondary with 2 grooves for double connections; primary side connections.

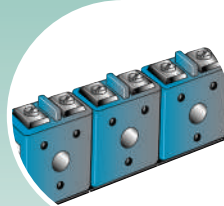

Mounting on plate or symmetrical rail



- Compact design
- Mounting on plate or rail

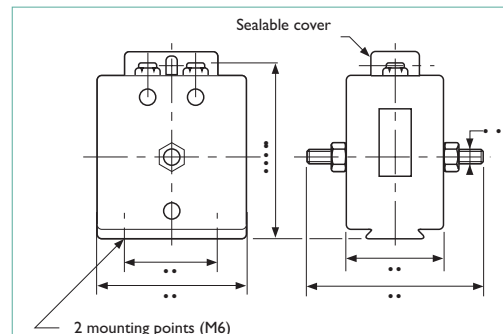

## TO ORDER

Model	Reference
<b>5 + 5 A (Secondary 5 A)</b>	JVMA 7523
<b>5 + 5 + 5 A (Secondary 5 A)</b>	JVMA 7524
<b>Sealable cover</b>	ACCE 7668

METERS AND POWER MONITORS

NETWORK MONITORING FROM LV TO HV

CURRENT TRANSFORMERS AND SHUNTS

TRANSDUCERS

PANEL METERS AND SYNCHROCOUPLER

AUXILIARY RELAYS

CIVILIAN AND MILITARY NAVAL APPLICATIONS

SERVICES AND TRAINING

# TRANSFORMER SHORT-CIRCUIT SWITCH

## USER SECTORS



Tertiary



Industry



Energy efficiency

Protection against the dangers caused by opening the secondary circuit on low-voltage measurement CTs.

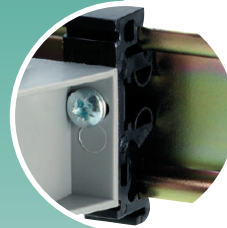
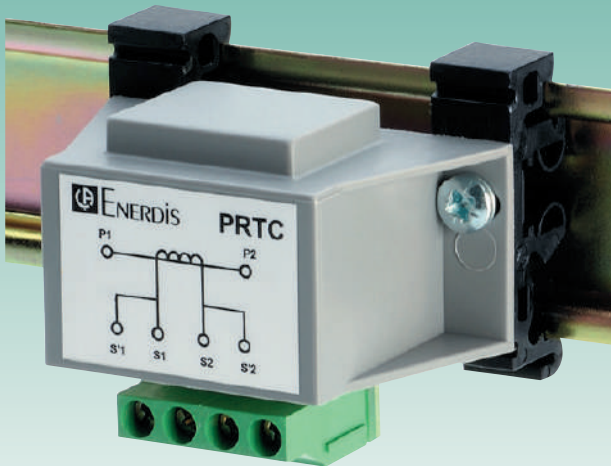

Mounting on DIN rail or plate



Four terminals available for 6 mm<sup>2</sup> wires

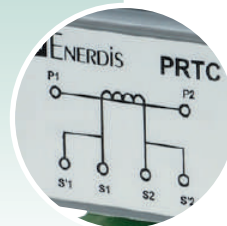

Connection diagram

## GENERAL SPECIFICATIONS

**Reference standards:** NFC 15100 art 411-1)

**Connections:** double terminals capable of receiving 6 mm<sup>2</sup> cables.

**DIN rail mounting** (supplied with fittings) or plate mounting using clamp bolts.

**Weight:** 90 g

**Operating conditions:** Temperature: -10°C to +50°C

**Relative humidity:** < 95%

**Protection:** Protection rating: IP 20

Self-extinguishing polyamide casing (UL 94VO)

**Measurement current:** 5 A/50 Hz or 1 A/50 Hz

**Maximum permitted current:** 25 Aac

**Peak protection voltage:** 22 Vac



- Protects users and equipment against overvoltages caused by opening the CT 5 A or 1 A secondary
- Automatic short-circuiting of CT secondary to which it is permanently connected
- Allows users to work without shutting down the load beforehand

## TO ORDER

Model	Reference
Transformer short-circuit switch	PRTC 1001

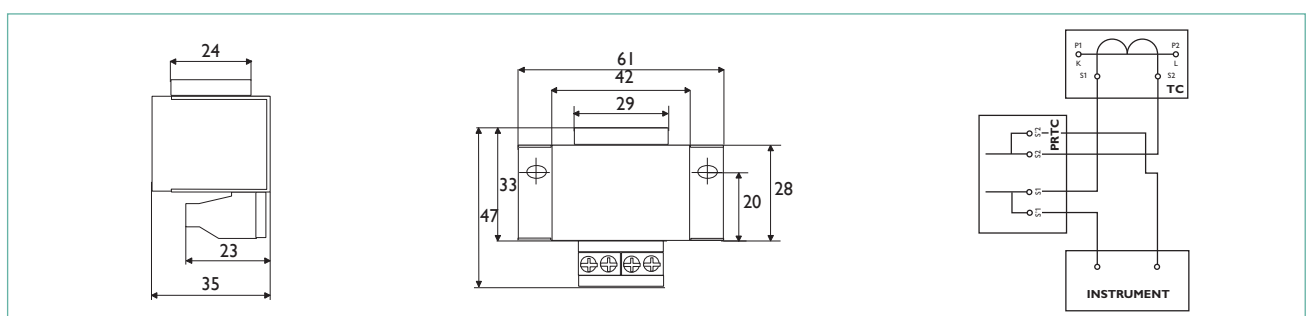



# CHOOSING YOUR SHUNTS

## TERTIARY AND INDUSTRIAL CURRENT SHUNTS

### 76-2 and 77-2

page 142

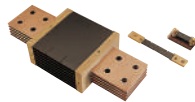

### SHMI

page 144



	76-2	76-2	77-2	SHMI	SHMI	SHMI
Type	Eye connection on base	Eye connection	Blade connection for busbar	Screw connection	Eye connection	Connection to block for busbar
Voltage drop				100 mV		
Accuracy class	0.2 and 0.5			0.5 and 1		
1 A	■			■		
1.25 A	■			■		
1.5 A	■			■		
2 A	■			■		
2.5 A	■			■		
3 A	■			■		
4 A	■			■		
5 A	■			■		
6 A	■			■		
7.5 A	■			■		
10 A		■		■		
15 A		■		■		
20 A		■		■		
25 A		■		■		
30 A		■			■	
40 A		■			■	
50 A		■			■	
60 A		■			■	
75 A		■			■	
100 A		■			■	
125 A		■			■	
150 A		■			■	
200 A		■			■	
250 A		■			■	
300 A		■			■	
400 A		■			■	
500 A		■			■	
600 A			■		■	
750 A			■		■	
1000 A			■			■
1250 A			■			■
1500 A			■			■
2000 A			■			■
2500 A			■			■
3000 A			■			■
4000 A			■			■
5000 A						■
6000 A						■
Strengths	High-performance range. High overload capacity. Treated against corrosion			Range with a good performance/price trade-off. Large choice of voltage drop ratings (on request).		

SPECIFIC PRODUCTS POSSIBLE IN THIS RANGE



# 76-2 AND 77-2 RANGES

A reference for measurements in demanding applications.

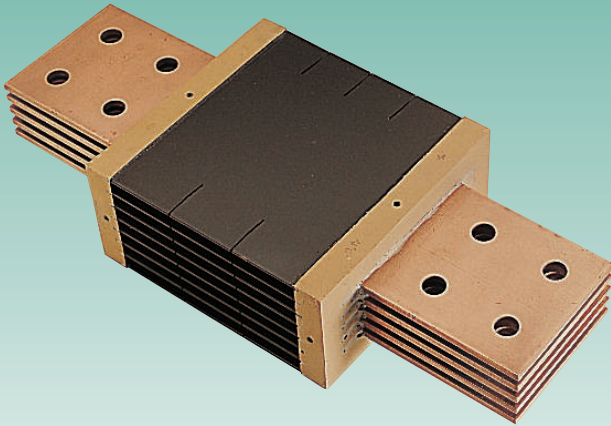

## USER SECTORS



Tertiary



Industry



Energy efficiency

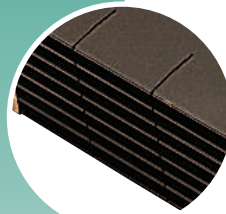

Protection against corrosion with epoxy-modified acrylic paint

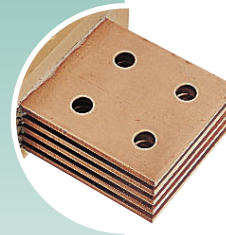

Large-area fittings to facilitate heat dissipation

## GENERAL SPECIFICATIONS

### Accuracy class defined in the following domain:

Over the whole measurement range, for an ambient temperature of:

-10°C to +35°C (Class 0.2)

-25°C to +40°C (Class 0.5 and 1)

For a blade temperature of 80°C

For a shunt current  $\leq 5$  mA

### Permitted rated calibres:

$I_n = 1$  A - 1.25 A - 1.5 A - 2 A - 2.5 A - 3 A - 4 A - 5 A - 6 A - 7.5 A ; their multiples or sub-multiples

### Voltage drops:

50 mV - 60 mV - 100 mV - 150 mV - 200 mV - 300 mV - 1 V

### Permitted overloads:

On average and in normal operating conditions



- High-performance range
- High overload capacity

### Compliance with standards:

Accuracy and influence factor: IEC 60051-1 to 9

Preferred calibres and dimensions for 100 mV shunts:

NFC 42-151/152/153z

Lead-free range: RoHS directive (2002/95/CE)

I nominal (I <sub>n</sub> )	2 h	5 s Class 0.2	5 s Class 0.5 et 1
< 250 A	1.2 I <sub>n</sub>	2 I <sub>n</sub>	10 I <sub>n</sub>
250 to 2000 A	1.2 I <sub>n</sub>	2 I <sub>n</sub>	5 I <sub>n</sub>
> 2000 A	1.2 I <sub>n</sub>	2 I <sub>n</sub>	2 I <sub>n</sub>

## 76-2 EYE CONNECTION ON BASE

Voltage drop: 100 mV  
Class 0.2 and 0.5

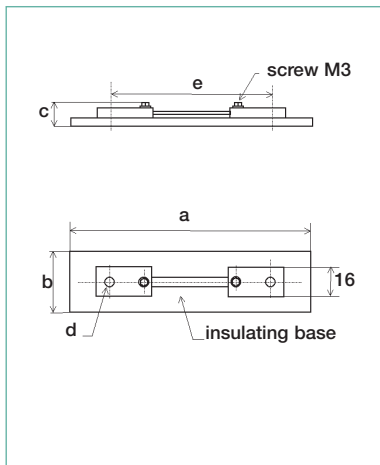

Current	Dimensions (mm)				
	a	b	c	d	e
1 A	150	20	13	6	130
1.25 A	150	20	13	6	130
1.5 A	150	20	13	6	130
2 A	150	20	13	6	130
2.5 A	150	20	13	6	130
3 A	150	20	13	6	130
4 A	150	20	13	6	130
5 A	150	20	13	6	130
6 A	150	20	13	6	130
7.5 A	150	20	13	6	130

## 76-2 EYE CONNECTION

Voltage drop: 100 mV  
Class 0.2 and 0.5

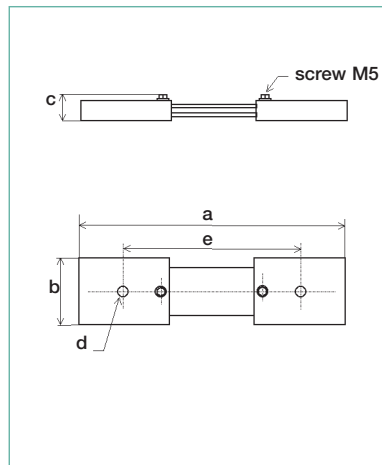

Current	Dimensions (mm)				
	a	b	c	d	e
10 A	160	16	11	6	130
15 A	160	16	11	6	130
20 A	160	16	11	6	130
25 A	160	16	11	6	130
30 A	190	25	11	10	160
40 A	190	25	11	10	160
50 A	190	25	11	10	160
60 A	190	25	11	10	160
75 A	190	25	11	10	160
100 A	190	32	11	10	160
125 A	220	32	13	14	180
150 A	220	32	13	14	180
200 A	220	32	13	14	180
250 A	220	50	13	14	180
300 A	220	50	13	14	180
400 A	240	60	17	18	200
500 A	240	60	17	18	200

## 77-2 BLADE CONNECTION FOR BAR

Voltage drop: 100 mV  
Class 0.2 and 0.5

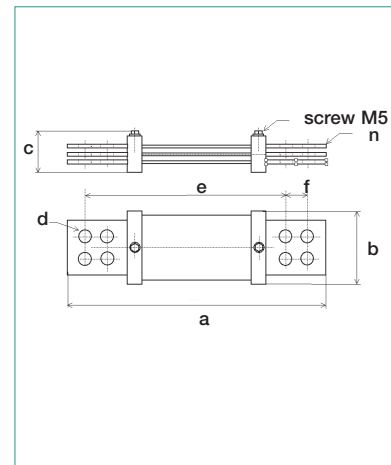

Current	Dimensions (mm)						
	a	b	c	d	e	f	n
600 A	280	80	35	11	220	25	1
750 A	280	80	35	11	220	25	1
1000 A	380	115	35	14	280	50	1
1250 A	380	115	35	14	280	50	1
1500 A	380	115	55	14	280	50	2
2000 A	380	115	55	14	280	50	2
2500 A	400	168	55	14	300	50	3
3000 A	400	168	65	14	300	50	4
4000 A	400	168	85	14	300	50	5

## TO ORDER

Current	Reference for 100 mV	
	Class 0.2	Class 0.5
1 A	SHUN 1200	SHUN 1300
1.25 A	SHUN 1201	SHUN 1301
1.5 A	SHUN 1202	SHUN 1302
2 A	SHUN 1203	SHUN 1303
2.5 A	SHUN 1204	SHUN 1304
3 A	SHUN 1205	SHUN 1305
4 A	SHUN 1206	SHUN 1306
5 A	SHUN 1207	P01 3042 11
6 A	SHUN 1208	SHUN 1308
7.5 A	SHUN 1209	SHUN 1309

Current	Reference for 100 mV	
	Class 0.2	Class 0.5
10 A	SHUN 1210	P01 3042 01
15 A	SHUN 1211	P01 3042 08
20 A	SHUN 1212	P01 3042 02
25 A	SHUN 1213	P01 3042 09
30 A	SHUN 1214	P01 3042 03
40 A	SHUN 1215	P01 3042 10
50 A	SHUN 1216	P01 3042 04
60 A	SHUN 1217	P01 3042 12
75 A	SHUN 1218	P01 3042 13
100 A	SHUN 1219	P01 3042 05
125 A	SHUN 1220	P01 3042 15
150 A	SHUN 1221	P01 3042 16
200 A	SHUN 1222	P01 3042 06
250 A	SHUN 1223	P01 3042 17
300 A	SHUN 1224	P01 3042 07
400 A	SHUN 1225	P01 3042 18
500 A	SHUN 1226	P01 3042 14

Current	Reference for 100 mV	
	Class 0.2	Class 0.5
600 A	SHUN 1227	P01 3042 48
750 A	SHUN 1228	P01 3042 41
1000 A	SHUN 1229	P01 3042 42
1250 A	SHUN 1230	P01 3042 49
1500 A	SHUN 1231	P01 3042 43
2000 A	SHUN 1232	P01 3042 44
2500 A	SHUN 1233	P01 3042 45
3000 A	SHUN 1234	P01 3042 46
4000 A	SHUN 1235	P01 3042 47

## CUSTOMIZED PRODUCT

	Model	Voltage drop	Accuracy class	Current
	76-2    77-2			
Example	77-2	50 mV	Class 0.2	800 A

# SHMI RANGE

Vast choice of industrial applications.

## USER SECTORS



Tertiary



Industry



Energy efficiency

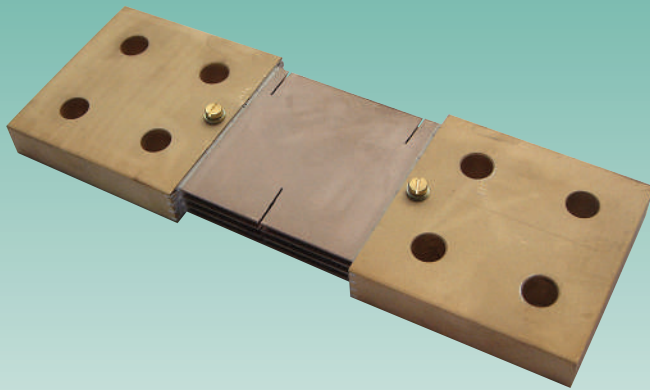

Easy-to-connect brass plates

## GENERAL SPECIFICATIONS

### Accuracy class defined in the following domain:

Over the entire measurement range  
 For an ambient temperature of:  
 -10°C to +35°C (class 0.2)  
 -25°C to +40°C (class 0.5 and 1)  
 For a blade temperature of 80°C  
 For a shunt current  $\leq 5$  mA

### Permitted rated calibres:

$I_n = 1$  A - 1.25 A - 1.5 A - 2 A - 2.5 A - 3 A - 4 A - 5 A - 6 A - 7.5 A ; and their multiples or sub-multiples

### Permitted overloads:

On average and in normal operating conditions

I nominal (In)	2 h	5 s Class 0.2	5 s Class 0.5 et 1
< 250 A	1.2 In	2 In	10 In
250 to 2000 A	1.2 In	2 In	5 In
> 2000 A	1.2 In	2 In	2 In

### Voltage drops:

50 mV - 60 mV - 100 mV - 150 mV - 200 mV - 300 mV - 1 V

### Compliance with standards:

Accuracy and influence factor: IEC 60051-1 to 9  
 Preferred ratings and dimensions for 100 mV shunts:  
 NFC 42-151/152/153  
 Lead-free range: RoHS directive (2002/95/CE)



- Range with excellent performance/price trade-off
- A wide choice of voltage drops
- Compact design that respects accepted thermal dissipation requirements

## MOUNTING ACCESSORIES

Kit of screw connectors + lead for shunt	Reference
1 to 25 A range	2919 9901
30 to 75 A range	2919 9902
100 A range	2919 9903
125 to 200 A range	2919 9904
250 to 500 A range	2919 9905
600 A and 750 A range	2919 9906

## ASSOCIATED PRODUCT



### Mounting accessories

Screws, bolts and cables  
 Ratings from 1 to 750 A.  
 page 144

## SHMI

### 1 A to 25 A SCREW CONNECTION

Voltage drop: 100 mV  
Class 0.5 and 1

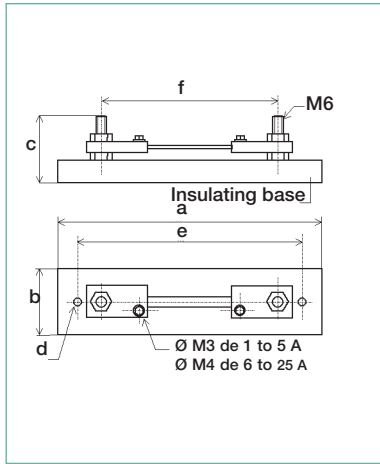

Dimensions (mm)

Current	a	b	c	d	e	f
1 A	162	25	40	3.5	152	110
2 A	162	25	40	3.5	152	110
2.5 A	162	25	40	3.5	152	110
3 A	162	25	40	3.5	152	110
4 A	162	25	40	3.5	152	110
5 A	162	25	40	3.5	152	110
6 A	162	25	40	3.5	152	110
7.5 A	162	25	40	3.5	152	110
10 A	162	25	40	3.5	152	110
15 A	162	25	40	3.5	152	110
20 A	162	25	40	3.5	152	110
25 A	162	25	40	3.5	152	110

## SHMI

### 30 A to 750 A SCREW CONNECTION

Voltage drop: 100 mV  
Class 0.5 and 1

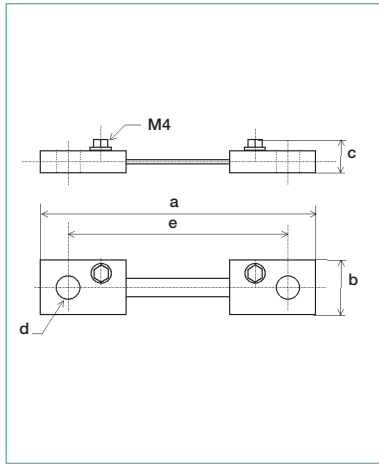

Dimensions (mm)

Current	a	b	c	d	e
30 A	150	16	10	8.5	130
40 A	150	16	10	8.5	130
50 A	150	16	10	8.5	130
60 A	150	16	10	8.5	130
75 A	150	16	10	8.5	130
100 A	150	21	10	8.5	130
125 A	150	32	10	8.5	130
150 A	150	32	10	8.5	130
200 A	150	32	14	8.5	130
250 A	210	52	13	14.5	180
300 A	210	52	13	14.5	180
400 A	210	52	17	14.5	180
500 A	210	52	17	14.5	180
600 A	210	52	22	14.5	180
750 A	210	52	22	14.5	180

## SHMI

### 1000 A to 6000 A BUSBAR CONNECTION BLOCK

Voltage drop: 100 mV  
Class 0.5 and 1

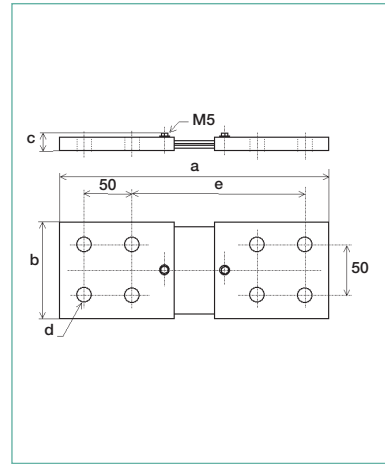

Dimensions (mm)

Current	a	b	c	d	e
1000 A	290	100	20	14.5	190
1250 A	290	100	25	14.5	190
1500 A	290	100	25	14.5	190
2000 A	290	100	35	14.5	190
2500 A	290	100	45	14.5	190
3000 A	290	100	45	14.5	190
4000 A	330	150	45	16.5	230
5000 A	330	150	45	16.5	230
6000 A	330	150	45	16.5	230

## TO ORDER

Reference for 100 mV

Current	Class 0.5	Class 1
1 A	2901 0301	2901 0101
2 A	2901 0303	2901 0103
2.5 A	2901 0304	2901 0104
3 A	2901 0305	2901 0105
4 A	2901 0306	2901 0106
5 A	2901 0307	2901 0107
6 A	2901 0308	2901 0108
7.5 A	2901 0310	2901 0110
10 A	2901 0312	2901 0112
15 A	2901 0314	2901 0114
20 A	2901 0315	2901 0115
25 A	2901 0316	2901 0116

Reference for 100 mV

Current	Class 0.2	Class 0.5
30 A	2901 0317	2901 0117
40 A	2901 0318	2901 0118
50 A	2901 0319	2901 0119
60 A	2901 0321	2901 0121
75 A	2901 0323	2901 0123
100 A	2901 0325	2901 0125
125 A	2901 0326	2901 0126
150 A	2901 0328	2901 0128
200 A	2901 0330	2901 0130
250 A	2901 0331	2901 0131
300 A	2901 0333	2901 0133
400 A	2901 0335	2901 0135
500 A	2901 0336	2901 0136
600 A	2901 0338	2901 0138
750 A	2901 0340	2901 0140

Reference for 100 mV

Current	Class 0.2	Class 0.5
1000 A	2901 0361	2901 0161
1250 A	2901 0362	2901 0162
1500 A	2901 0363	2901 0163
2000 A	2901 0364	2901 0164
2500 A	2901 0365	2901 0165
3000 A	2901 0366	2901 0166
4000 A	2901 0368	2901 0168
5000 A	2901 0369	2901 0169
6000 A	2901 0370	2901 0170

## CUSTOMIZED PRODUCT

	Model	Voltage drop	Accuracy class	Current
	SHMI			
Example	SHMI	50 mV	Class 0.5	3000 A

# SHEL AND SHMO RANGES

For simplified installation on low-power networks.

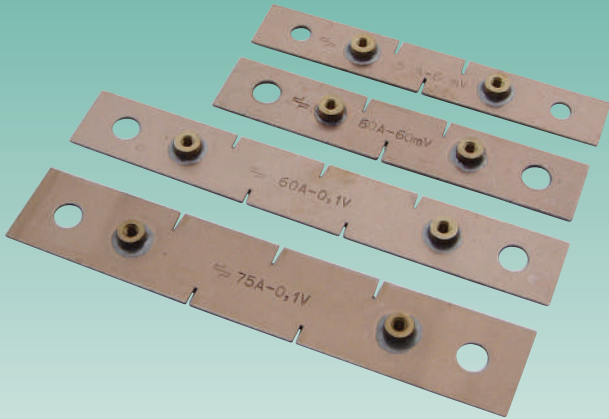

## GENERAL SPECIFICATIONS

### Accuracy class 1 defined in the following domain:

- Over the entire measurement range
- For an ambient temperature of -25°C to +40°C
- For a blade temperature of 80°C
- For a shunt current  $\leq 5$  mA

### Permitted rated calibres:

$I_n = 1$  A - 1.25 A - 1.5 A - 2 A - 2.5 A - 3 A - 4 A - 5 A - 6 A - 7.5 A and their multiples or sub-multiples  
Max. 300 A for SHEL and 60 A for SHMO

**Permitted rated calibres:** 50 mV - 60 mV - 100 mV

I nominal (In)	2 h	5 s
< 250 A	1.2 In	10 In
> 250 A	1.2 In	5 In

### Permitted overloads:

On average and in normal operating conditions

### Compliance with standards:

Accuracy and influence factor: IEC 60051-1 to 9  
Lead-free range: RoHS directive (2002/95/CE)

## USER SECTORS



Tertiary



Industry



Energy efficiency



- Economy range for construction (SHEL) and for simplified installation (SHMO)
- Direct connection to measuring component (SHEL)
- 1 V modular casing for quick and easy mounting (SHMO)
- Compact design (SHEL)

## SHEL

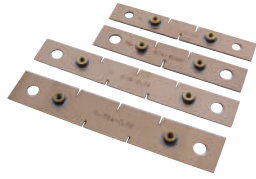

Voltage drop: 100 mV Class 1

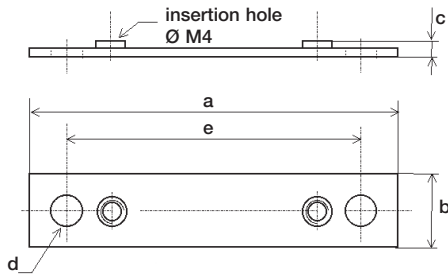

Dimensions (mm)

Current	a	b	c	d	e
10 A	150	10	5	6.5	122
15 A	150	12	5	6.5	122
20 A	150	12	5	6.5	122
25 A	150	15	5	6.5	122
30 A	150	15	5	6.5	122
40 A	150	15	5	6.5	122
50 A	150	20	5	6.5	122
60 A	150	25	5	8.5	122
75 A	150	30	5	8.5	122
100 A	150	20	6	8.5	122
125 A	150	25	6	8.5	122
150 A	150	30	6	8.5	122
200 A	150	40	6	10.5	122
250 A	150	50	6	10.5	122
300 A	150	60	6	10.5	122

## TO ORDER

Reference for 100 mV

Current	Class 1
10 A	2901 0246
15 A	2901 0247
20 A	2901 0227
25 A	2901 0228
30 A	2901 0229
40 A	2901 0230
50 A	2901 0231
60 A	2901 0232
75 A	2901 0233
100 A	2901 0235
125 A	2901 0236
150 A	2901 0237
200 A	2901 0238
250 A	2901 0239
300 A	2901 0248

Reference for 100 mV

Current	Class 1
1 A	2925 0101
5 A	2925 0107
10 A	2925 0112
15 A	2925 0114
20 A	2925 0115
25 A	2925 0116
30 A	2925 0117
40 A	2925 0118
50 A	2925 0119
60 A	2925 0121

## CUSTOMIZED PRODUCT

	Model	Voltage drop	Accuracy class	Current
	SHEL SHMO			
Example	SHEL	50 mV	Class 1	80 A

## SHMO

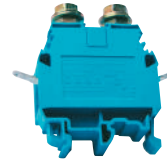

Voltage drop: 100 mV Class 1

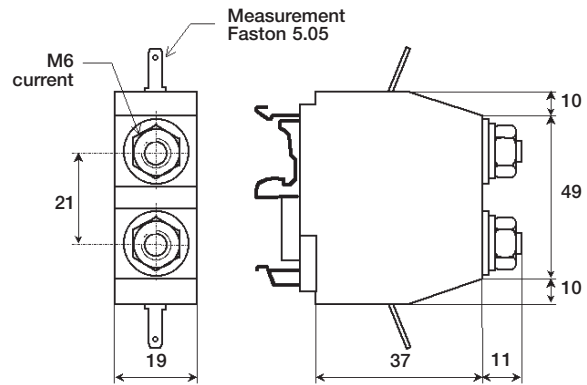

METERS AND  
POWER MONITORS

NETWORK MONITORING  
FROM LV TO HV

CURRENT TRANSFORMERS  
AND SHUNTS

TRANSDUCERS

PANEL METERS AND  
SYNCHROCOUPLER

AUXILIARY RELAYS

CIVILIAN AND MILITARY  
NAVAL APPLICATIONS

SERVICES AND TRAINING



**NETWORK SUPERVISION AND PHYSICAL MEASUREMENT**

# TRANSDUCERS



- 150 OVERVIEW OF THE RANGE
- 155 CHOOSING YOUR TRANSDUCER
- 156 DIGITAL TRANSDUCERS
- 172 ANALOG TRANSDUCERS
- 184 COMMUNICATION SOLUTION

METERS AND  
POWER MONITORS

NETWORK MONITORING  
FROM LV TO HV

CURRENT TRANSFORMERS  
AND SHUNTS

TRANSDUCERS

PANEL METERS AND  
SYNCHROCOUPLER

AUXILIARY RELAYS

CIVILIAN AND MILITARY  
NAVAL APPLICATIONS

SERVICES AND TRAINING

# TRANSDUCERS

## DIGITAL TRANSDUCERS

1, 2, 3 or 4 configurable analog outputs / Class 0.1  
1 Ethernet or RS485 digital output

Vac	Uac	Iac	P	Q	S	F	PF
Tanφ	Cosφ	φ	φU	φV			



### TRIAD 2 Configured at the factory AC quantities

Programmable digital transducers, 1 to 4 analog outputs. Configurable accuracy class. [page 156](#)



### TRIAD 2 Configurable via TRIADJUST 2 AC quantities

Programmable digital transducers, 1 to 4 analog outputs. Configurable accuracy class. [page 156](#)

## ANALOG TRANSDUCERS

For nuclear environments



### T82N 1 analog output / Class 0.5 Suitable for the requirements of the nuclear market. [page 172](#)

Vac	Iac	P	Q	F	PF
T°C	Vdc	Idc			

## COMMUNICATION SOLUTION

For nuclear environments



### ELINK 61850 ModBus / IEC 61850 gateway For TRIAD 2 transducers. [page 184](#)

Vac	Iac	P	Q	F	PF
-----	-----	---	---	---	----

## USER SECTORS

---



Energy generation



Energy transmission & distribution



Nuclear



Naval applications

METERS AND POWER MONITORS

NETWORK MONITORING FROM LV TO HV

CURRENT TRANSFORMERS AND SHUNTS

TRANSDUCERS

PANEL METERS AND SYNCHROCOUPLER

AUXILIARY RELAYS

CIVILIAN AND MILITARY NAVAL APPLICATIONS

SERVICES AND TRAINING

# INFO & ADVICE

## TRANSDUCERS



Transducers measure or physical quantities and transmit them as a standard analog signal (Vdc or mA).

### FACTORY-PROGRAMMED OR USER-PROGRAMMABLE?

#### Factory-programmed

If the specifications of the measurements required are known, a **factory-programmed** transducer can be used.

#### User-programmable

If the precise specifications of the measurements are not known, choose a **user-programmable** transducer. You can then program it accordingly when the specifications are known and you can modify the settings if these specifications change.



## WHICH TRANSFER CURVES SHOULD YOU CHOOSE?

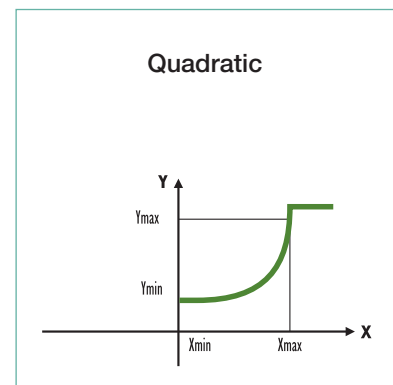
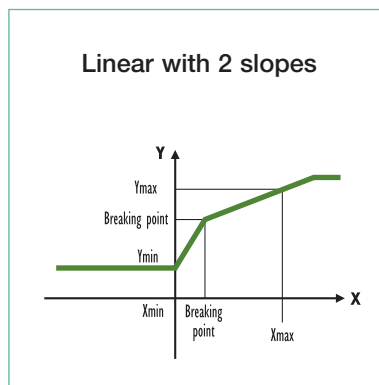
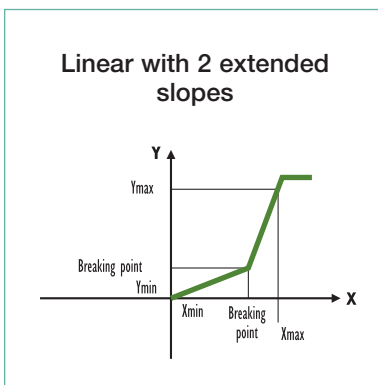
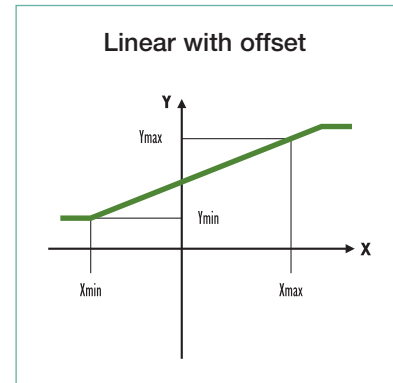
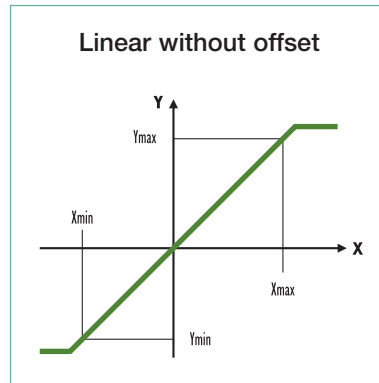
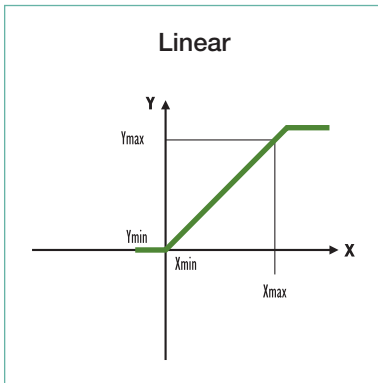

## ACCURACY CLASS AND IEC 688 STANDARD

The IEC 688 standard defines the accuracy class as the limits of the intrinsic error expressed as a percentage of the output interval.

### Example:

For a measurement range of 0 - 1.000 kW, an output interval of 16 mA (output 4-20 mA) and an accuracy class of 0.2, the intrinsic error is:

$$\frac{0.2}{100} \times 16 \text{ mA} = \pm 0.032 \text{ mA}$$

representing a measurement uncertainty of  $\pm 2$  kW over the complete measurement range 0 - 1.000 kW.

## EDF TYPE HN 44-S-80 AND IEC 61000-6-5 SPECIFICATIONS

When designing our products, we take into account the requirements and constraints linked to EDF's technical specifications to ensure that they can withstand severe environments.

- electrical power stations
- switching stations
- source stations

Compliance with the requirements of the leading French electricity supplier helps Chauvin Arnoux Energy to achieve recognition nationally and international.

## ADVANTAGES OF ANALOG OUTPUTS

---

### Universality

The nature of the output signal from the measurement transducer enables quick and easy connection to a wide range of instruments (recorders, controllers, calculators, analog and digital panel meters, measurement relays, PLCs, RTUs, etc.).

### Response time

The response time of an analog output enables real-time viewing of all electrical parameters (for example, SCADA application, dispatching, control and monitoring of industrial processes).

### Resistance to disturbances

Analog signals (current outputs in particular) are not significantly affected by electromagnetic disturbances. A single shielded-pair wire enables you to transmit the output signal over very long distances (several hundred meters without signal amplification).

### Reliability

Analog transducer technology offers the advantage of several decades of application and use, benefiting from wide experience in such varied fields as industry, building automation and electrical network supervision (dispatching).

## ADVANTAGES OF PROGRAMMABLE TRANSDUCERS

---

The configuration software associated with transducers enables you to adapt transducer specifications to application needs at all times and stages of the application.

### Reduction of stocks and maintenance costs

A programmable transducer can replace any other product as necessary, helping to reduce stocks for maintenance.

### Adaptable to changes on installations

The programmable transducer can be modified at all times, especially in the case of modification of initial specifications or information unavailable at the outset.

### Quickly and easily replaceable products

Programmability makes it easy to replace products quickly, thus cutting maintenance time.

## ADVANTAGES OF DIGITAL OUTPUTS

---

### Remote access for easy maintenance

With digital outputs, it is possible to create a communicating network so that you can set the products' parameters remotely.

### Extra functions

The digital outputs on our transducers can be used to access functions which were previously unavailable, such as alarms, date-stamping or energy index functions.

### Remote data retrieval

Using the commands available in the ModBus mapping, a transducer can be operated via a digital supervision system and retrieve remotely all the electrical quantities available per product on the same bus.

# CHOOSING YOUR TRANSDUCER

## TRIAD 2

page 156



## T82N

page 172



Measurements		
Iac	■	■
Vac	■	■
Uac	■	
Vdc		■
P	■	■
Q	■	■
S	■	
F	■	■
PF	■	■
Cosφ	■	
Tanφ	■	
φ	■	
φ (U' - U'')	■	
Temperature		■
kWh	■	
kVAh	■	
kVAh	■	
Current/voltage unbalance	■	
Options		
Number of analog outputs	4	1
RS485	■	
Ethernet	■	
Pulse output		
Alarm output		
Relay output	■	
Programmable	■	
Plug-in versions		■
Self-powered	(1)	

(1) By looping the input voltage

METERS AND  
POWER MONITORS

NETWORK MONITORING  
FROM LV TO HV

CURRENT TRANSFORMERS  
AND SHUNTS

TRANSDUCERS

PANEL METERS AND  
SYNCHROCOUPLER

AUXILIARY RELAYS

CIVILIAN AND MILITARY  
NAVAL APPLICATIONS

SERVICES AND TRAINING

# TRIAD 2 RANGE

Programmable digital transducers with 1 to 4 analog outputs.  
Programmable accuracy class.



## USER SECTORS



Energy generation



Energy transmission & distribution



Naval applications



Multi-function, economical instrument with 4 functions in the same Casing



Communication: Ethernet, RS 485 or optical head



Accessibility and safety: large-dimension terminals Insulated circuits



Ergonomic: easy mounting on DIN rail or switchboard

## Main specifications

**Quantities measured:** 1, 2, 3, 4 to be chosen from I, V, U, F, PF, P, Q, S,  $\cos\phi$ ,  $\phi$ ,  $\phi U$ ,  $\phi V$ ,  $\tan\phi$

**Configuration of TRIAD 2:** in factory or by the user with the TRIADJUST 2 software

**Accuracy (programmable):** class 0.1 / 0.15 / 0.2 / 0.5 / 1  
Current inputs: 1A and 5 A

**Voltage inputs:** 100 to 480 V (ph-ph) or  $100/\sqrt{3}$  to  $480/\sqrt{3}$  V (ph-N)

**Transfer curves:** linear, 2 slopes or quadratic

**Output signals:**  $\pm 1\text{mA}$ ,  $\pm 5\text{mA}$ ,  $\pm 20\text{mA}$ ,  $\pm 1\text{V}$ ,  $\pm 10\text{V}$

**Response time** down to 50 ms

**Operating frequency:** 50 or 60 Hz

**Auxiliary power supply with wide dynamic range:**  
80 to 265 V ac/dc or 19 to 58 Vdc

**Compliance with CE directive**

Digital technology



- Up to 4 programmable analog outputs
- 4 kV insulation
- Configurable and modifiable: using the TRIADJUST 2 software
- Adjustable accuracy within Class 0.1 as per IEC 60688
- Digital output available as an option

## FACTORY-PROGRAMMABLE

- The transducer delivered is ready to operate and can be connected to the electrical network in order to deliver output signals tailored for your installation.
- To benefit from this, you simply need to know the exact specifications of your electrical installation:
  - Type of network: split-phase, balanced or unbalanced three-phase, 3 or 4 wires.
  - Type of electrical connections.
  - Number of electrical quantities to be measured: 1, 2, 3 or 4.
  - Precise measurement ranges of the input/output quantities to be measured.

Users can modify a factory configuration at any time with the TRIADJUST 2 software if the specifications of the electrical network change.

## ENVIRONMENT AND STANDARDS

EMC IMMUNITY (STANDARD OF REFERENCE: IEC 60688, IEC 61326-1, IEC 61000-6-5)	
Shock voltage as per IEC 61000-4-5	2 kV in differential mode 4 kV in common mode
Oscillating wave as per IEC 61000-4-12	1 kV in differential mode 2.5 kV in common mode
Fast electrical transients in bursts as per IEC 61000-4-4	2 kV on power supply 2 kV on inputs/outputs
Electrostatic discharge as per IEC 61000-4-2	8 kV in the air 6 kV in contact
EM radiated field as per IEC 61000-4-3	10 V/m (80 Mhz to 3 GHz)
Voltage dips as per IEC 61000-4-11	30% reduction during 20 ms 60% reduction during 1 s
Voltage interruptions as per IEC 61000-4-11	100% reduction during 100 ms 100% reduction during 100 ms
EMC emissions	
Radiated and conducted	As per CISPR11
Climatic specifications (IEC 60068 2-1/2-2/2-30)	
Operating temperature	-10°C to +55°C
Storage temperature	-40°C to +70°C
Relative humidity	≤ 95% to 55°C
Safety specifications (IEC 61010-1)	
Installation category	3
Pollution level	2
Fire resistance	UL94, severity V0
Mechanical specifications (IEC 60068 2-6/2-27/2-29/2-32/2-63)	
Protection rating	IP 20
Mechanical shocks	IEC 60068-2-27
Vibrations	IEC 60068-2-6
Drop test with packaging	NF H0042-1

## MOUNTING ACCESSORIES

Model	Reference
Plate mounting for T1xy	ACCT 1007
Plate mounting for T3xy	ACCT 1006

## PROGRAMMABLE VIA TRIADJUST 2

- With the TRIADJUST 2 software and one of the 3 communication modes available (Ethernet, RS485 or optical head) you can program all the parameters characterizing a TRIAD 2 transducer.
- To do so, simply choose a model which suits your electrical installation:
  - Type of network: split-phase, balanced or unbalanced three-phase, 3 or 4 wires.
  - Number of analog outputs required (1, 2 3 or 4).
  - Value of the auxiliary source.
- You are then free to configure the TRIAD 2 transducer delivered as you wish and to print out the stickers corresponding to the parameters programmed.

## CASING

Weight	320 g (T1xy) / 700 g (T3xy)
Mounting	DIN rail 43700 or plate mounting
Connection	Terminals with mobile stirrup clamp with screw for 4 single-wire 6 mm <sup>2</sup> conductors or 2 multi-wire 4 mm <sup>2</sup> conductors

## HARDWARE IDENTIFICATION

The TRIAD 2 T1xy and T3xy are fully configurable with the TRIADJUST 2 software which allows users to modify the characteristics of their products right up to the last minute.

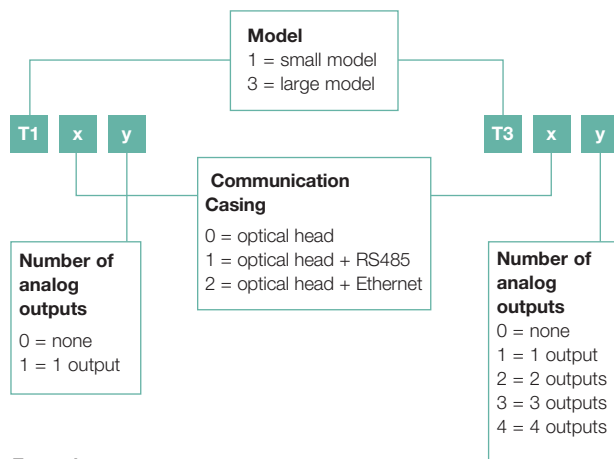

### Example:

T314 = Large-model TRIAD 2 with optical head and RS485 + 4 analog outputs

Network	Function	T1xy model	T3xy model
Single-phase	V	■	■
	I	■	■
	F	■	■
	P	■	■
	Q	■	■
	S	■	■
	PF	■	■
	Tanφ	■	■
	Cosφ	■	■
	φ	■	■
	Energy values*	■	■
Balanced 3-phase, 3 wires	U12, U23, U31	■	■
	I1, I2, I3	■	■
	F	■	■
	Pt	■	■
	Qt	■	■
	St	■	■
	PfT	■	■
	Tanφ	■	■
	Cosφt	■	■
	φt	■	■
	Energy values*	■	■
Balanced 3-phase, 4 wires	V1, V2, V3	■	■
	U12, U23, U31	■	■
	I1, I2, I3	■	■
	F	■	■
	P1, P2, P3, Pt	■	■
	Q1, Q2, Q3, Qt	■	■
	S1, S2, S3, St	■	■
	PF1, PF2, PF3, PfT	■	■
	Tanφ	■	■
	Cos (φ1, φ2, φ3, φt)	■	■
	φ1, φ2, φ3, φt	■	■
Energy values*	■	■	
Unbalanced 3-phase, 3/4 wires	V1, V2, V3	■	■
	U12, U23, U31	■	■
	I1, I2, I3	■	■
	F	■	■
	P1, P2, P3, Pt	■	■
	Q1, Q2, Q3, Qt	■	■
	S1, S2, S3, St	■	■
	PF1, PF2, PF3, PfT	■	■
	Tanφ	■	■
	Cos (φ1, φ2, φ3, φt)	■	■
	φ1, φ2, φ3, φt	■	■
	φ (U12/U23, U23/U31, U31/U12)	■	■
	φ (V1/V2, V2/V3, V3/V1)	■	■
	Current unbalance	■	■
Energy values*	■	■	
Split-phase	V1, V2	■	■
	U12	■	■
	I1, I2	■	■
	F	■	■
	P1, P2, Pt	■	■
	Q1, Q2, Qt	■	■
	S1, S2, St	■	■
	PF1, PF2, PfT	■	■
	Tanφ	■	■
	Cos (φ1, φ2, φt)	■	■
	φ1, φ2, φt	■	■
	φ (V1/V2)	■	■
	I1 signed, I2 signed	■	■
	Energy values*	■	■

\* Accessible via the product's Modbus communication

## ELECTRICAL SPECIFICATIONS

Voltage input		
Rated value	T1: from 57.7 Vac to 276 Vac max. T3: from 57.7 Vac to 480 Vac max.	
Frequency	50 Hz: 42.5...57.5 Hz 60 Hz: 51...69 Hz	
Max. measured voltage on primary	1 MV (ph-ph)	
Acceptable overloads	T1: 300 Vac permanent - 460 Vac / 10s T3: 520 Vac permanent - 800 Vac / 10s	
Consumption	< 0.2 VA	
Input impedance	400 kΩ	
Current inputs		
Rated value	0 to 10 A max.	
Max. measured current on primary	40,000 A	
Acceptable overload	50 In / 1 s	
Consumption	< 0.15 VA	
Auxiliary power supply		
High level	80 / 265 Vac (50/60 Hz) – 80 / 265 Vdc	
Low level	19 / 58 Vdc	
Consumption	High level T1: 3.3 VA to 8.5 VA max. T3: 9 VA to 20 VA max.	Low level T1: 3.2 W to 5.5 W max. T3: 5.5 W to 11 W max.
Analog outputs		
Rated values	Current	Voltage
	± 1mA, ± 5mA, ± 20mA	± 1 V, ± 10 V
Acceptable resistive load	15 V / I <sub>o</sub> <sup>(1)</sup>	≥ 1 kΩ
Acceptable capacitive load	0.1 μF	0.1 μF
Overrun	1.2 I <sub>o</sub> <sup>(1)</sup>	1.2 U <sub>o</sub> <sup>(1)</sup>
Peak-peak residual wave	± 0.2 % of I <sub>o</sub> <sup>(1)</sup>	± 0.2 % of U <sub>o</sub> <sup>(1)</sup>
Programmable response time	50 ms – 100 ms – 200 ms – 500 ms – 1 s	
Transfer curve	Linear, 2 slopes or quadratic	

(1) I<sub>o</sub> = output current, U<sub>o</sub> = output voltage

## COMMUNICATION

	Optical head	Ethernet	RS485
Connection	USB (PC) Optical (product)	RJ45	2 wires Half-duplex
Protocol	MODBUS RTU mode	MODBUS / TCP RTU mode	MODBUS / JBUS RTU mode
Speed	38 400 bauds	10 base T	2.400 to 115.200 bauds
Parity	-	-	Even, odd or none
JBus addresses	-	-	1 to 247
Transmission length	2 m	100 m	As per EIA 485

## METROLOGICAL SPECIFICATIONS

Measurements	Accuracy class over measurement range (as per IEC 60688)				
	RT = 50 ms*	RT = 100 ms*	RT = 200 ms*	RT = 500 ms*	RT = 1s*
V, U, I, F, P, Q, S, PF, Tanφ, Cosφ, φ, φU, φV**	± 0.5 %	± 0.3 %	± 0.2 %	± 0.15 %	± 0.1 %

RT: Response time for F = 50 Hz

\* These values may change according to the input and output measurement ranges

\*\* Phase angle between voltages for φU and φV

### ELECTRICAL CONNECTIONS - SINGLE-PHASE NETWORK

I1, F:

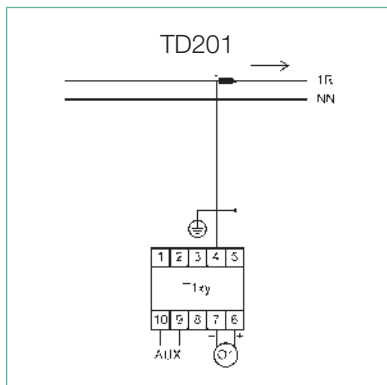

V1, F:

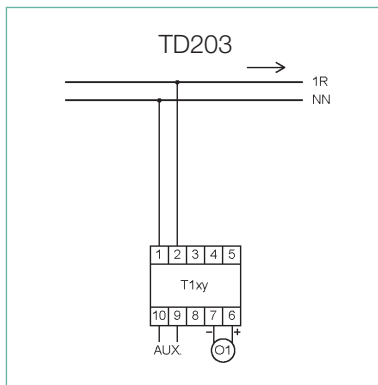

V1, I1, P1, Q1, S1, PF1, F,  
TANφ, Cosφ1, φ1:

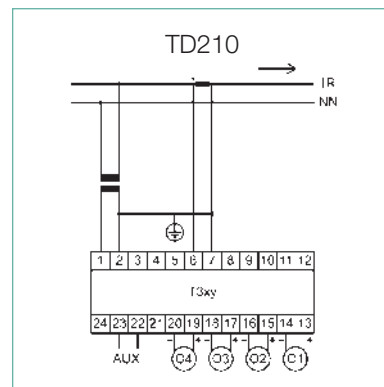
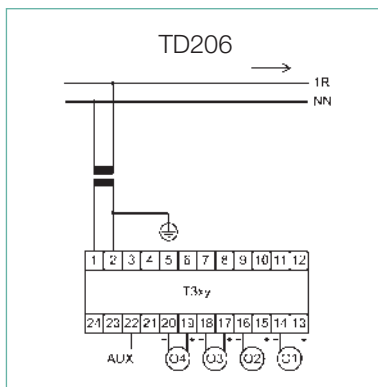
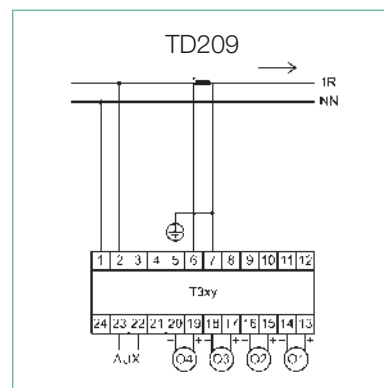
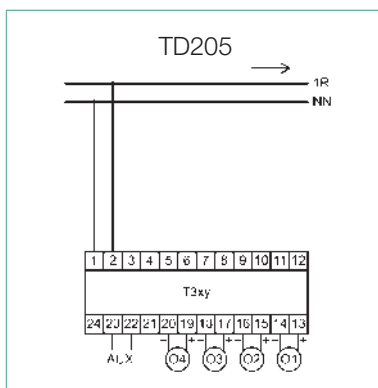
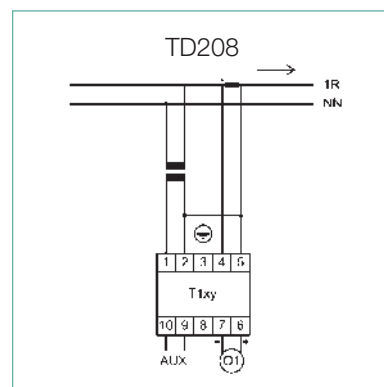
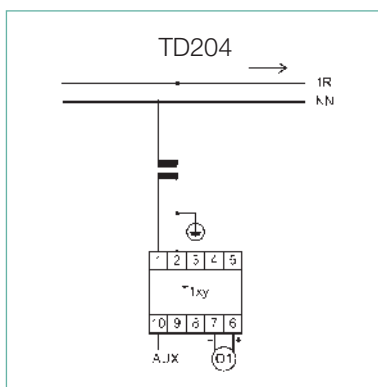
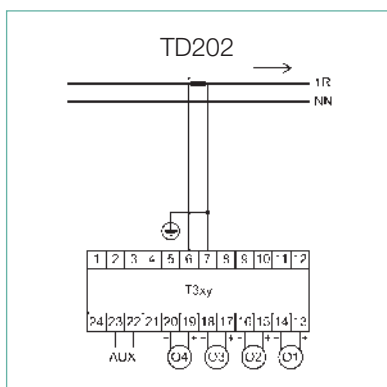
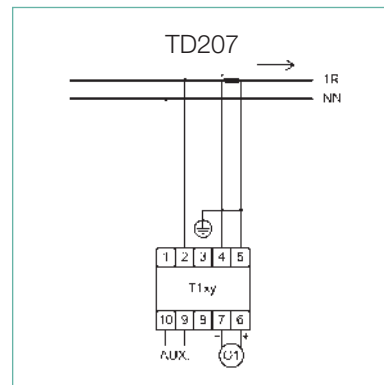

## BALANCED 3-PHASE, 3-WIRE NETWORK

U12, U23, U31, F:

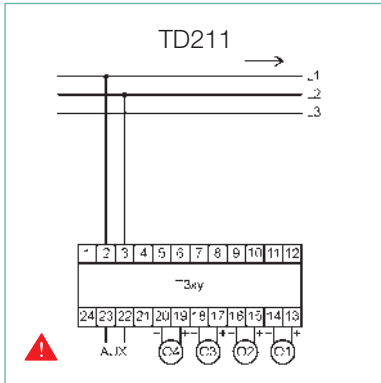

I1, I2, I3, F:

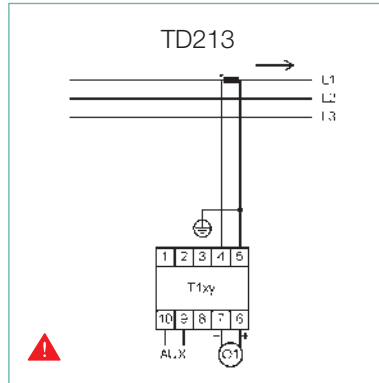

U12, U23, U31, I1, I2, I3, Pt, St, Qt, Pft, F, TANφ, Cosφt, φt :

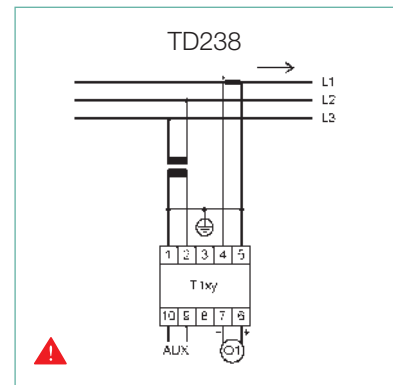
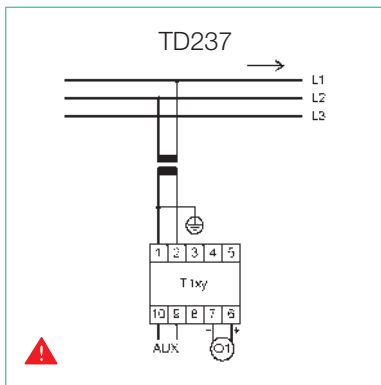
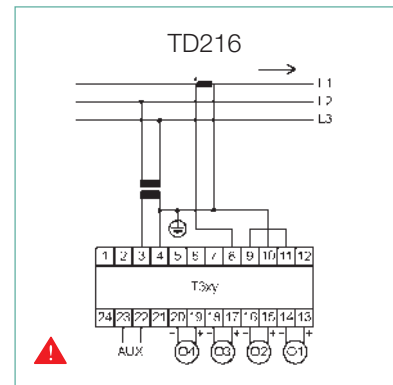
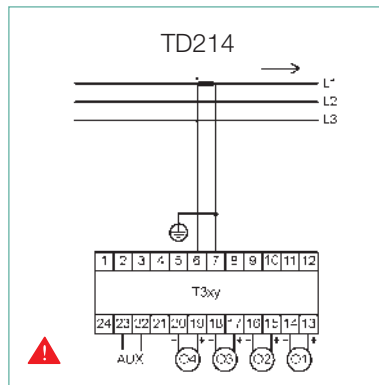
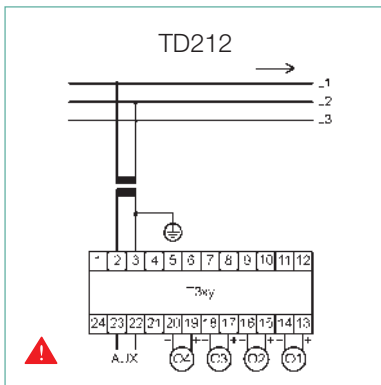
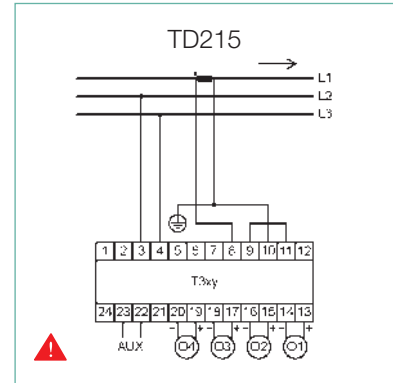

 Phase rotation authorized

### BALANCED 3-PHASE, 4-WIRE NETWORK

V1, V2, V3, U12, U23, U31, I1, I2, I3, P1, P2, P3, Pt, S1, S2, S3, St, Q1, Q2, Q3, Qt, PF1, PF2, PF3, PFT, F, TANφ, Cosφ1, Cosφ2, Cosφ3, Cosφt, φ1, φ2, φ3, φt:

V1, V2, V3, U12, U23, U31 F:

I1, I2, I3, F:

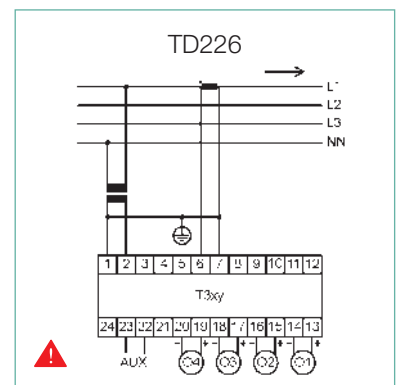
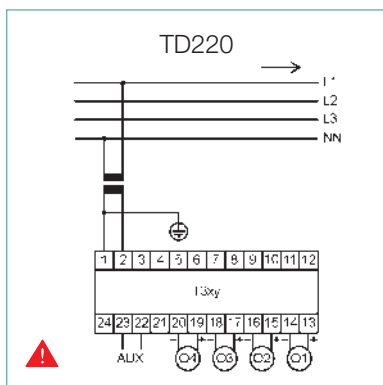
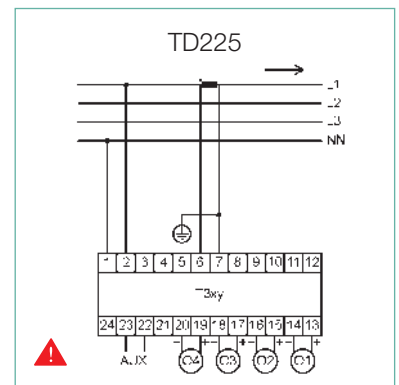
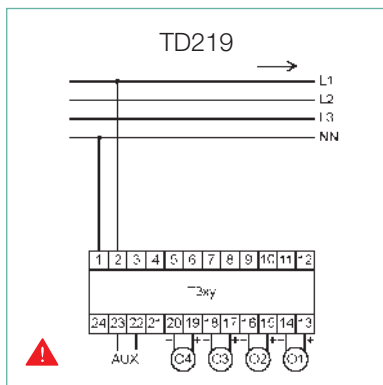
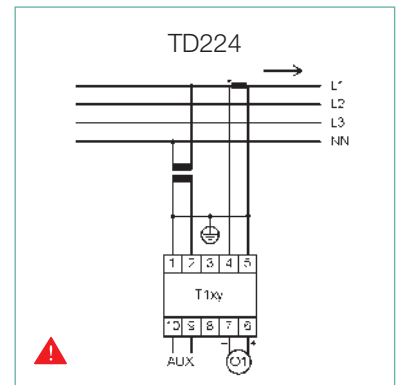
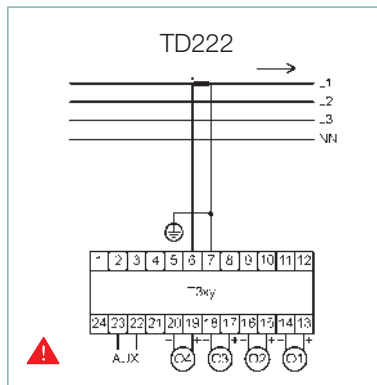
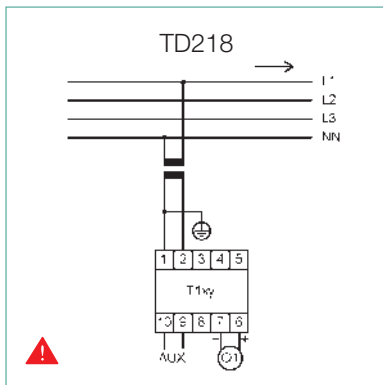
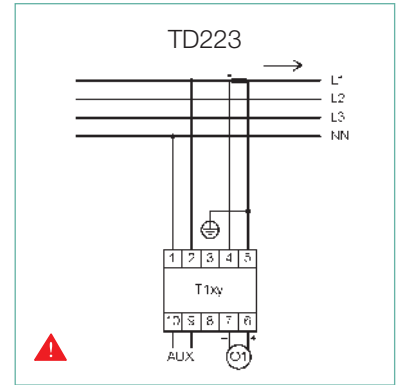
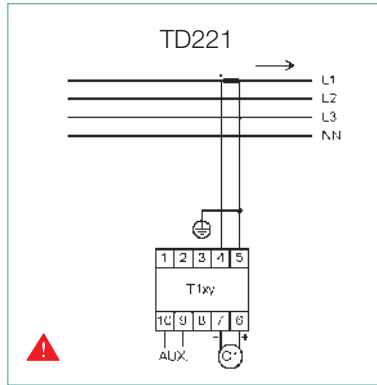
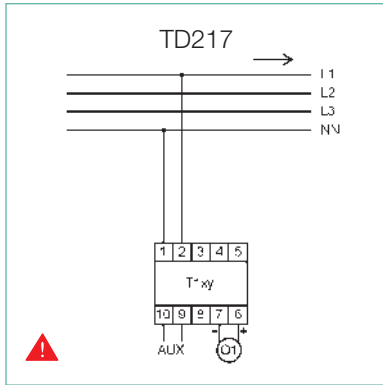

 Phase rotation authorized

## UNBALANCED 3-PHASE, 4-WIRE NETWORK

U12, U23, U31, F,  
Angle (U12/U23, U23/U31, U31/  
U12):

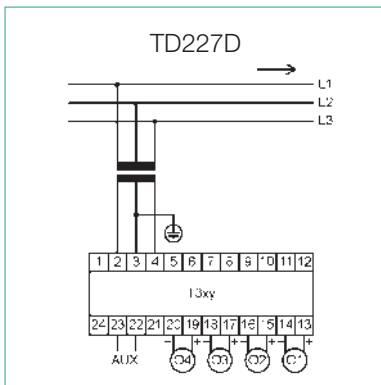
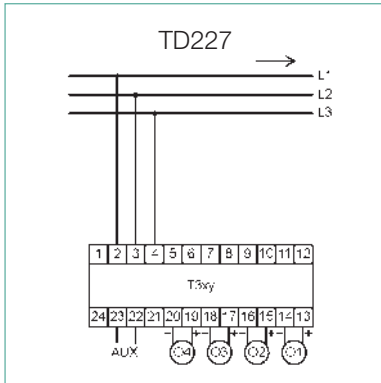

V1, V2, V3, U12, U23, U31, F,  
Angle (V1/V2, V2/V3, V3/V1),  
Angle (U12/U23, U23/U31, U31/  
U12):

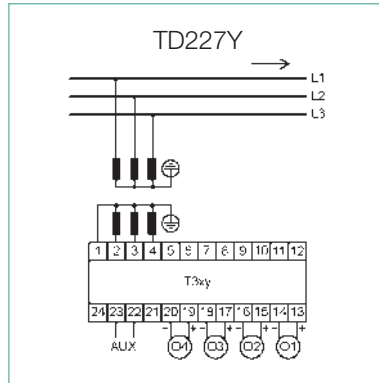

I1, I2, I3, F:

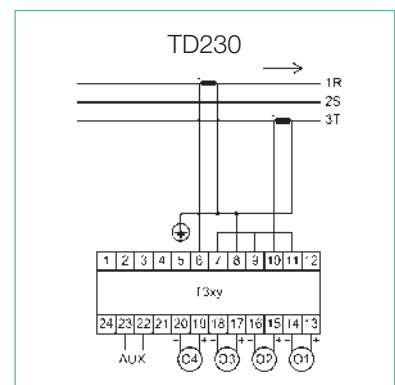
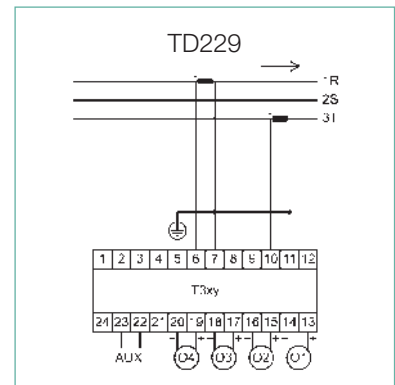
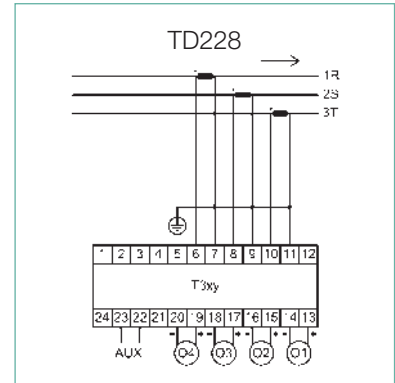

**UNBALANCED 3-PHASE, 3-WIRE NETWORK (DIRECT CURRENTD)**

U12, U23, U31, I1, I2, I3, Pt, St, Qt, PFt, F, TANφ,  
Cosφt, φt,  
Angle (U12/U23, U23/U31, U31/U12):

V1, V2, V3, U12, U23, U31, I1, I2, I3, P1, P2, P3, Pt, S1, S2, S3, St, Q1, Q2, Q3, Qt, PF1, PF2, PF3, PFt, F, TANφ, Cosφ1, Cosφ2, Cosφ3, Cosφt, φ1, φ2, φ3, φt, Angle (V1/V2, V2/V3, V3/V1), Angle (U12/U23, U23/U31, U31/U12):

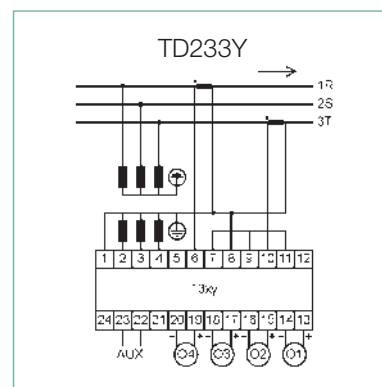
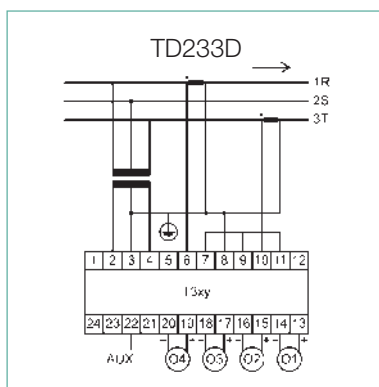
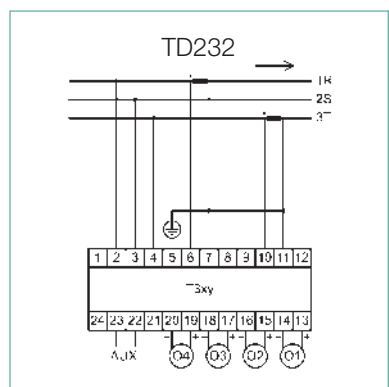
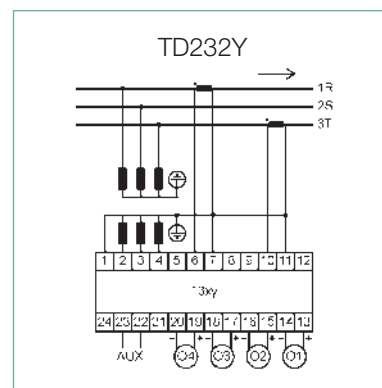
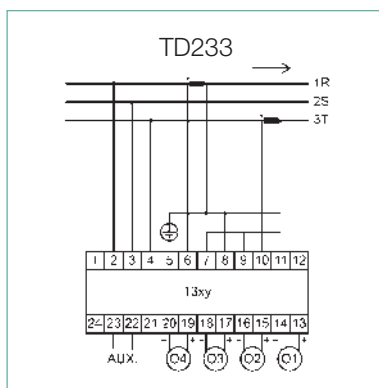
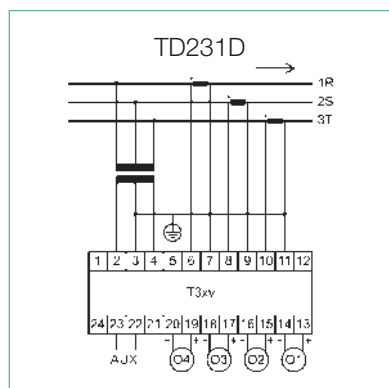
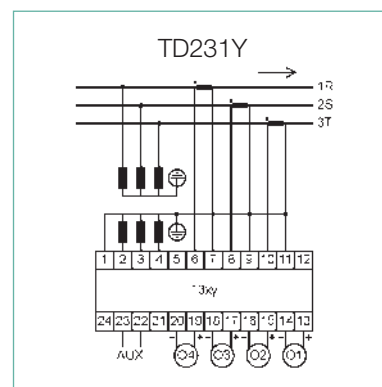
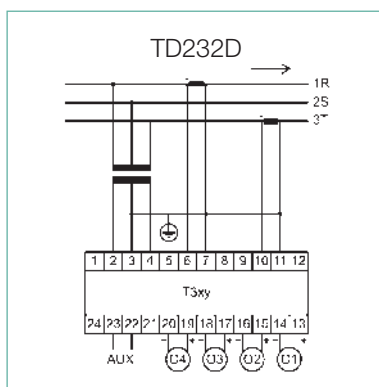
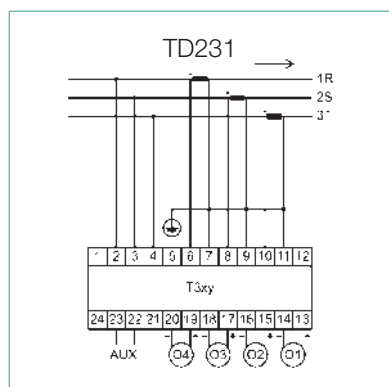

# UNBALANCED 3-PHASE, 4-WIRE NETWORK

I1, I2, I3, F:

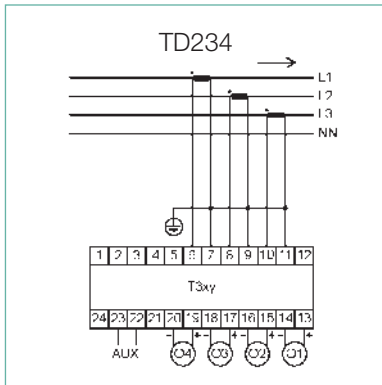

V1, V2, V3, U12, U23, U31, F,  
Angle (V1/V2, V2/V3, V3/V1),  
Angle (U12/U23, U23/U31, U31/  
U12):

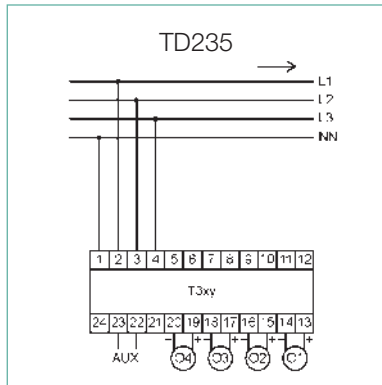

V1, V2, V3, U12, U23, U31, I1,  
I2, I3, P1, P2, P3, Pt, S1, S2,  
S3, St, Q1, Q2, Q3, Qt, PF1,  
PF2, PF3, PFt, F, TANφ, Cosφ1,  
Cosφ2, Cosφ3, Cosφt, φ1, φ2,  
φ3, φt  
Angle (V1/V2, V2/V3, V3/V1),  
Angle (U12/U23, U23/U31, U31/  
U12):

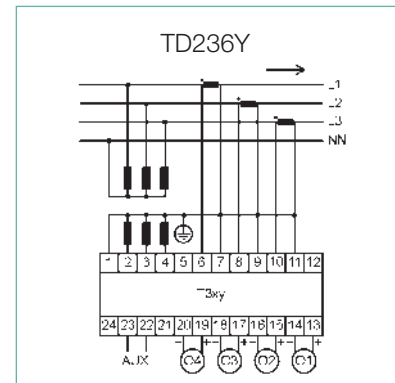
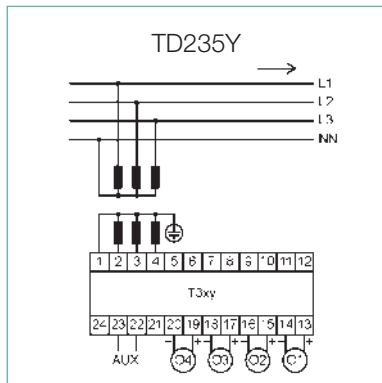
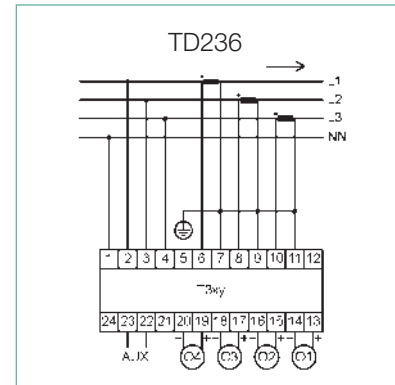

## SPLIT-PHASE

I1, I2, F :

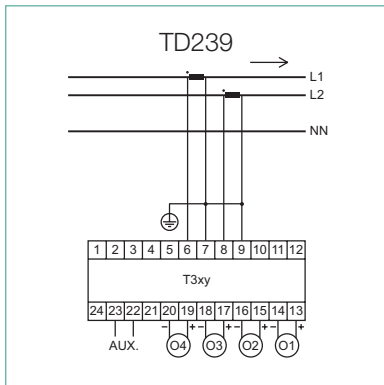

V1, V2, U12, F, Angle (V1/V2) rad,  
Angle (V1/V2) deg :

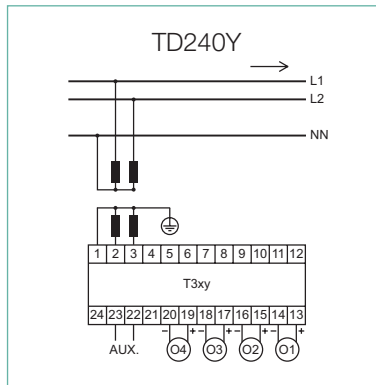

V1, V2, U12, I1, I2, P1, P2, Pt,  
Q1, Q2, Qt, S1, S2, St, PF1,  
PF2, PFt, F, tanφ, Angle (V1/V2) rad,  
Angle (V1/V2) deg, cos φ1,  
cos φ2, cosφt, φ1 Fund rad,  
φ2 Fund rad, φt Fund rad, φ1 Fund deg,  
φ2 Fund deg, φt Fund deg, Angle V1/V2 Fund deg, I1 (signed), I2 (signed) :

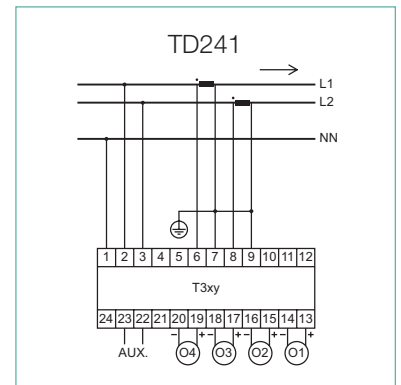
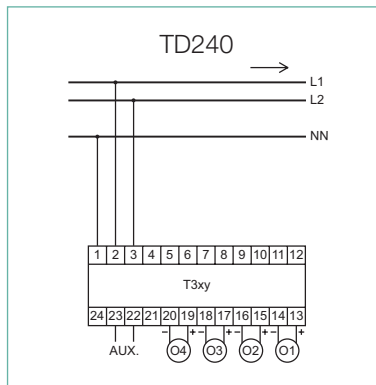
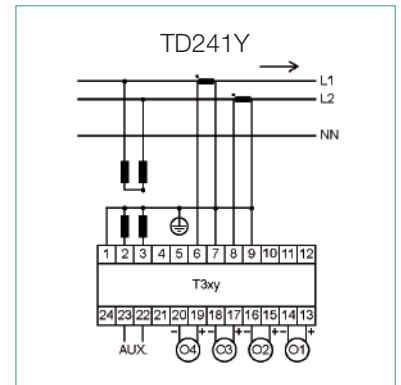

**DIMENSIONS ( IN MM )**

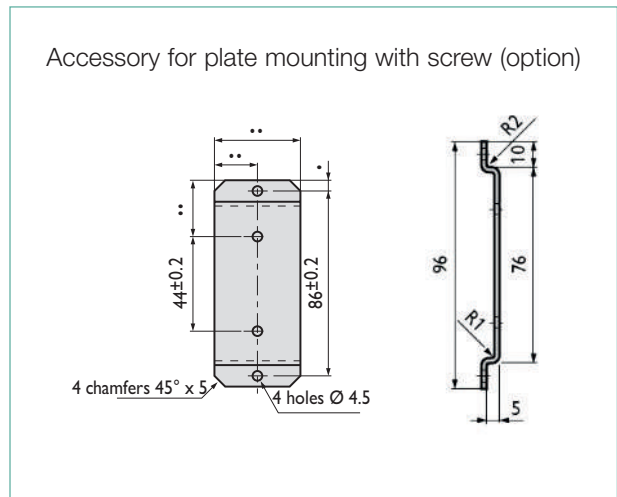
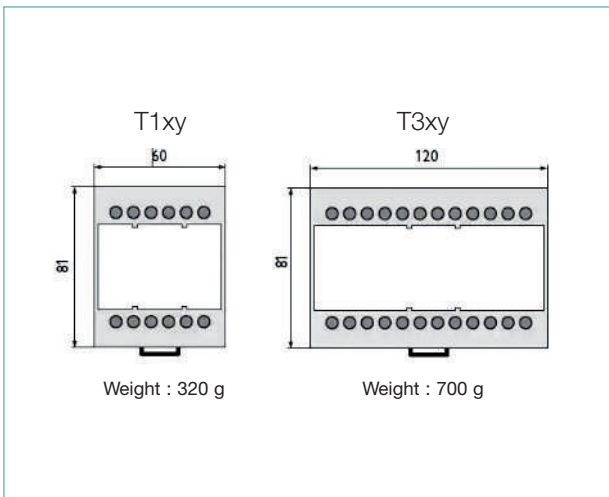
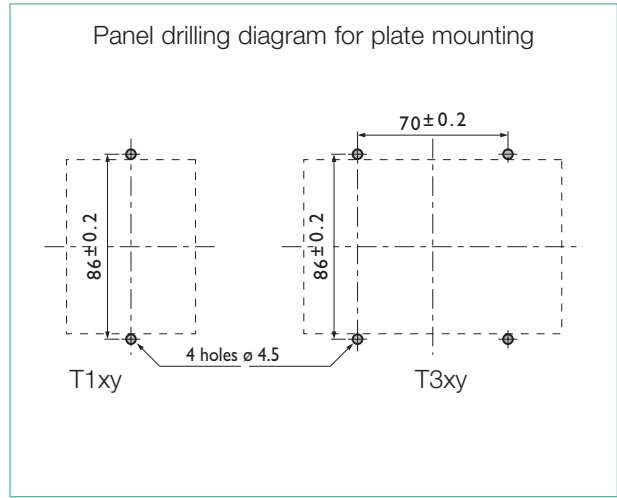
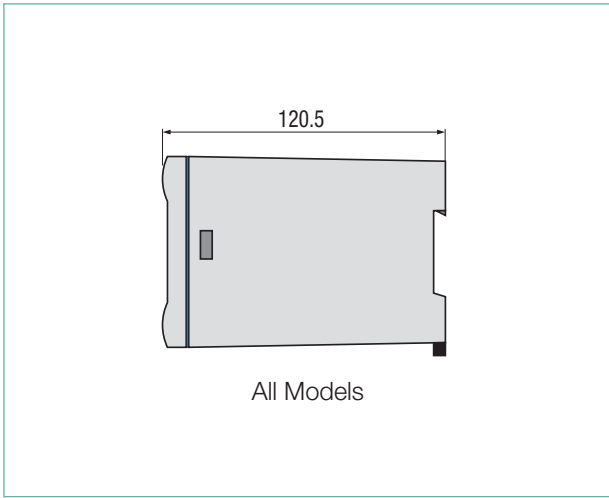

## TRIAD 2 PROGRAMMABLE VIA TRIADJUST 2

### TO ORDER

			T1 - SMALL MODEL (60 x 81 x 120.5 mm)		T3 - LARGE MODEL (120 x 81 x 120.5 mm)							
			Without tropicalization	With tropicalization	Without tropicalization				With tropicalization			
			Number of outputs	Number of outputs	Number of outputs				Number of outputs			
Link	Output	Alimentation	1	1	1	2	3	4	1	2	3	4
Optical	± 20 mA	80 - 265 V AC/DC	P01380001	P01380002	P01380101	P01380103	P01380105	P01380107	P01380102	P01380104	P01380106	P01380108
		19 - 58 V DC	P01380003	P01380004	P01380109	P01380111	P01380113	P01380115	P01380110	P01380112	P01380114	P01380116
	± 10 V	80 - 265 V AC/DC	P01380005	P01380006	P01380117	P01380119	P01380121	P01380123	P01380118	P01380120	P01380122	P01380124
		19 - 58 V DC	P01380007	P01380008	P01380125	P01380127	P01380129	P01380131	P01380126	P01380128	P01380130	P01380132

## TRIAD 2 FACTORY-PROGRAMMABLE

### 1 - Model - Frequency

T1	Small model – 1 analog output
T3	Large model – 1 to 4 analog output(s)
0	50 Hz
1	60 Hz

### 2 - Network

0	Single-phase
1	Balanced 3-phase, 3 wires
2	Balanced 3-phase, 4 wires
3	Unbalanced 3-phase, 3 wires
4	Unbalanced 3-phase, 4 wires
5	Split-phase

### 3 - Communication - Connection

0	Without
1	RS485
2	Ethernet

Indicate the diagram number. E.g. TD204

### 4 - Supply

0	80-265 Vac / 110-375 Vdc
1	19-58 V DC

### 5 - Tropicalization

0	Without
1	With

### 6 - Inputs

Voltage	Indicate direct voltage to be measured or the VT ratio
Current	Indicate direct current to be measured or the CT ratio

### 7 - Number of analog outputs

0	Without (Choice of a minimum communication)
1	1 output
2	2 outputs (T3 model only)
3	3 outputs (T3 model only)
4	4 outputs (T3 model only)

### 8 - Analog outputs

Indicate for each output:

a-	Quantity to be measured
b-	Transfer curve
c-	Input signal: Min – Breaking point - Max
d-	Measurement unit
e-	Output signal: Min – Breaking point - Max

### 9 - Analog output ratings\*

0	- 20 mA to + 20 mA
1	- 5 mA to + 5 mA
2	- 1 mA to + 1 mA
3	- 10 V to + 10 V
4	- 1 V to + 1 V

\* Attention: option 0 is not suitable for use with the -5 mA to +5 mA and -1 mA to +1 mA ratings. Option 3 is not suitable for use with the -1 V to +1 V rating.

To simplify the procedure when ordering you can send us the form on page 169.

# FACTORY-PROGRAMMED TRIAD 2: ORDER FORM

<b>1 - Model / Hz</b>	<b>2 - Network</b>	<b>3 - Communication / Connection</b>
<input type="checkbox"/> T1 or <input type="checkbox"/> T3 <input type="checkbox"/> 50 Hz or <input type="checkbox"/> 60 Hz	<input type="checkbox"/> Single-phase <input type="checkbox"/> 3-wire balanced three-phase <input type="checkbox"/> 4-wire balanced three-phase <input type="checkbox"/> 3-wire unbalanced three-phase <input type="checkbox"/> 4-wire unbalanced three-phase <input type="checkbox"/> Split-phase	<input type="checkbox"/> Ethernet or <input type="checkbox"/> RS485 <input type="checkbox"/> Tropicalization Connection diagram: TD <input type="text"/> <input type="text"/> <input type="text"/> <input type="text"/> cf: p.172
<b>4 - Power supply</b> <input type="checkbox"/> 80 to 265 Vac (50/60 Hz) / 110 to 375 Vdc or <input type="checkbox"/> 19 to 58 Vdc		<b>5 - Tropicalization</b> <input type="checkbox"/> With <input type="checkbox"/> Without

## 6 - Inputs

<b>Current</b> With current transformer          ou          Direct Primary          Secondary <input type="text"/> / <input type="text"/> A <input type="text"/> A	<b>Voltage</b> With voltage transformer          or          Direct Primary          Secondary <input type="text"/> / <input type="text"/> V <input type="text"/> V <input type="checkbox"/> Phase-phase <input type="checkbox"/> Phase-neutral (√3)
--	--

**Available quantities**

V1	V2	V3	U12	U23	U31	I1	I2	I3	F	P1	P2	P3	Pt	Q1	Q2	Q3	Qt
S1	S2	S3	St	PF1	PF2	PF3	PFt	TANφ	COSφ1	COSφ2	COSφ3	COSφt					
φ1	φ2	φ3	φt	φU12/23φU23/31φU31/12	V1/2	V2/3	V3/1	I1	I2	I3	signé						

**7 - Number of analog outputs**

0 : Without (Choice of a minimum communication)  
 1 : 1 output  
 2 : 2 outputs (T3 model only)  
 3 : 3 outputs (T3 model only)  
 4 : 4 outputs (T3 model only)

## 8 / 9 - Analog outputs calibres

<b>Output 1</b> Quantity and measurement range (x) <input type="text"/> Indicate quantity to be measured Min    Breaking point    Max    Unit <sup>(1)</sup> <input type="text"/> <input type="text"/> <input type="text"/> <input type="text"/>	Transfer curve <input type="checkbox"/> Linear <input type="checkbox"/> 2 slopes <input type="checkbox"/> Quadratic	Output signal (y) Min    Breaking point    Max <input type="text"/> <input type="text"/> <input type="text"/> <input type="checkbox"/> mA <input type="checkbox"/> V	Accuracy class <sup>(2)</sup> <table border="1"> <thead> <tr> <th></th> <th>50 Hz</th> <th>60 Hz</th> </tr> </thead> <tbody> <tr><td><input type="checkbox"/></td><td>0.1 %</td><td>1 s 0.8 s</td></tr> <tr><td><input type="checkbox"/></td><td>0.15 %</td><td>0.5 s 0.4 s</td></tr> <tr><td><input type="checkbox"/></td><td>0.2 %</td><td>0.2 s 0.16 s</td></tr> <tr><td><input type="checkbox"/></td><td>0.3 %</td><td>100ms 80ms</td></tr> <tr><td><input type="checkbox"/></td><td>0.5 %</td><td>50ms 40ms</td></tr> </tbody> </table>		50 Hz	60 Hz	<input type="checkbox"/>	0.1 %	1 s 0.8 s	<input type="checkbox"/>	0.15 %	0.5 s 0.4 s	<input type="checkbox"/>	0.2 %	0.2 s 0.16 s	<input type="checkbox"/>	0.3 %	100ms 80ms	<input type="checkbox"/>	0.5 %	50ms 40ms
	50 Hz	60 Hz																			
<input type="checkbox"/>	0.1 %	1 s 0.8 s																			
<input type="checkbox"/>	0.15 %	0.5 s 0.4 s																			
<input type="checkbox"/>	0.2 %	0.2 s 0.16 s																			
<input type="checkbox"/>	0.3 %	100ms 80ms																			
<input type="checkbox"/>	0.5 %	50ms 40ms																			

<b>Output 2</b> Quantity and measurement range (x) <input type="text"/> Indicate quantity to be measured Min    Breaking point    Max    Unit <sup>(1)</sup> <input type="text"/> <input type="text"/> <input type="text"/> <input type="text"/>	Transfer curve <input type="checkbox"/> Linear <input type="checkbox"/> 2 slopes <input type="checkbox"/> Quadratic	Output signal (y) Min    Breaking point    Max <input type="text"/> <input type="text"/> <input type="text"/> <input type="checkbox"/> mA <input type="checkbox"/> V	Accuracy class <sup>(2)</sup> <table border="1"> <thead> <tr> <th></th> <th>50 Hz</th> <th>60 Hz</th> </tr> </thead> <tbody> <tr><td><input type="checkbox"/></td><td>0.1 %</td><td>1 s 0.8 s</td></tr> <tr><td><input type="checkbox"/></td><td>0.15 %</td><td>0.5 s 0.4 s</td></tr> <tr><td><input type="checkbox"/></td><td>0.2 %</td><td>0.2 s 0.16 s</td></tr> <tr><td><input type="checkbox"/></td><td>0.3 %</td><td>100ms 80ms</td></tr> <tr><td><input type="checkbox"/></td><td>0.5 %</td><td>50ms 40ms</td></tr> </tbody> </table>		50 Hz	60 Hz	<input type="checkbox"/>	0.1 %	1 s 0.8 s	<input type="checkbox"/>	0.15 %	0.5 s 0.4 s	<input type="checkbox"/>	0.2 %	0.2 s 0.16 s	<input type="checkbox"/>	0.3 %	100ms 80ms	<input type="checkbox"/>	0.5 %	50ms 40ms
	50 Hz	60 Hz																			
<input type="checkbox"/>	0.1 %	1 s 0.8 s																			
<input type="checkbox"/>	0.15 %	0.5 s 0.4 s																			
<input type="checkbox"/>	0.2 %	0.2 s 0.16 s																			
<input type="checkbox"/>	0.3 %	100ms 80ms																			
<input type="checkbox"/>	0.5 %	50ms 40ms																			

<b>Output 3</b> Quantity and measurement range (x) <input type="text"/> Indicate quantity to be measured Min    Breaking point    Max    Unit <sup>(1)</sup> <input type="text"/> <input type="text"/> <input type="text"/> <input type="text"/>	Transfer curve <input type="checkbox"/> Linear <input type="checkbox"/> 2 slopes <input type="checkbox"/> Quadratic	Output signal (y) Min    Breaking point    Max <input type="text"/> <input type="text"/> <input type="text"/> <input type="checkbox"/> mA <input type="checkbox"/> V	Accuracy class <sup>(2)</sup> <table border="1"> <thead> <tr> <th></th> <th>50 Hz</th> <th>60 Hz</th> </tr> </thead> <tbody> <tr><td><input type="checkbox"/></td><td>0.1 %</td><td>1 s 0.8 s</td></tr> <tr><td><input type="checkbox"/></td><td>0.15 %</td><td>0.5 s 0.4 s</td></tr> <tr><td><input type="checkbox"/></td><td>0.2 %</td><td>0.2 s 0.16 s</td></tr> <tr><td><input type="checkbox"/></td><td>0.3 %</td><td>100ms 80ms</td></tr> <tr><td><input type="checkbox"/></td><td>0.5 %</td><td>50ms 40ms</td></tr> </tbody> </table>		50 Hz	60 Hz	<input type="checkbox"/>	0.1 %	1 s 0.8 s	<input type="checkbox"/>	0.15 %	0.5 s 0.4 s	<input type="checkbox"/>	0.2 %	0.2 s 0.16 s	<input type="checkbox"/>	0.3 %	100ms 80ms	<input type="checkbox"/>	0.5 %	50ms 40ms
	50 Hz	60 Hz																			
<input type="checkbox"/>	0.1 %	1 s 0.8 s																			
<input type="checkbox"/>	0.15 %	0.5 s 0.4 s																			
<input type="checkbox"/>	0.2 %	0.2 s 0.16 s																			
<input type="checkbox"/>	0.3 %	100ms 80ms																			
<input type="checkbox"/>	0.5 %	50ms 40ms																			

<b>Output 4</b> Quantity and measurement range (x) <input type="text"/> Indicate quantity to be measured Min    Breaking point    Max    Unit <sup>(1)</sup> <input type="text"/> <input type="text"/> <input type="text"/> <input type="text"/>	Transfer curve <input type="checkbox"/> Linear <input type="checkbox"/> 2 slopes <input type="checkbox"/> Quadratic	Output signal (y) Min    Breaking point    Max <input type="text"/> <input type="text"/> <input type="text"/> <input type="checkbox"/> mA <input type="checkbox"/> V	Accuracy class <sup>(2)</sup> <table border="1"> <thead> <tr> <th></th> <th>50 Hz</th> <th>60 Hz</th> </tr> </thead> <tbody> <tr><td><input type="checkbox"/></td><td>0.1 %</td><td>1 s 0.8 s</td></tr> <tr><td><input type="checkbox"/></td><td>0.15 %</td><td>0.5 s 0.4 s</td></tr> <tr><td><input type="checkbox"/></td><td>0.2 %</td><td>0.2 s 0.16 s</td></tr> <tr><td><input type="checkbox"/></td><td>0.3 %</td><td>100ms 80ms</td></tr> <tr><td><input type="checkbox"/></td><td>0.5 %</td><td>50ms 40ms</td></tr> </tbody> </table>		50 Hz	60 Hz	<input type="checkbox"/>	0.1 %	1 s 0.8 s	<input type="checkbox"/>	0.15 %	0.5 s 0.4 s	<input type="checkbox"/>	0.2 %	0.2 s 0.16 s	<input type="checkbox"/>	0.3 %	100ms 80ms	<input type="checkbox"/>	0.5 %	50ms 40ms
	50 Hz	60 Hz																			
<input type="checkbox"/>	0.1 %	1 s 0.8 s																			
<input type="checkbox"/>	0.15 %	0.5 s 0.4 s																			
<input type="checkbox"/>	0.2 %	0.2 s 0.16 s																			
<input type="checkbox"/>	0.3 %	100ms 80ms																			
<input type="checkbox"/>	0.5 %	50ms 40ms																			

(1) Please indicate the unit of the measurement range, e.g. W, kW or MW.  
 (2) These values may change according to the input and output measurement ranges.

# TRIADJUST 2 SOFTWARE

Designed for quick configuration and display of all the parameters of your TRIAD 2 transducers.

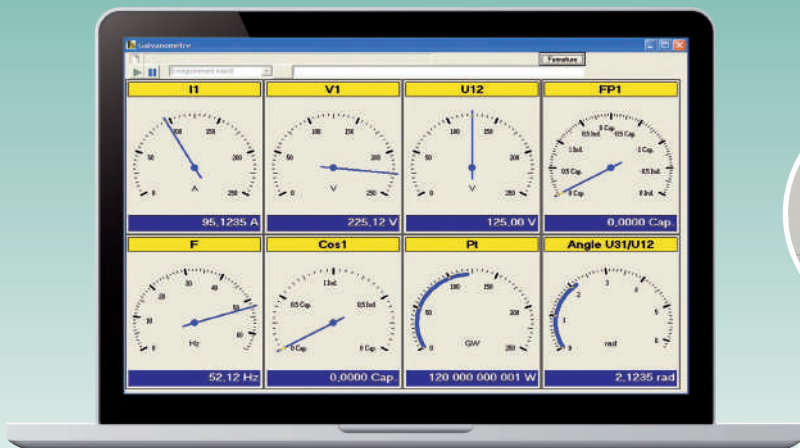

## Description

The **TRIADJUST 2** software allows quick, unlimited programming of all your TRIAD 2's parameters.

Using a PC and the optical lead supplied in each kit, connect your product's auxiliary power supply to dialog with total security. Depending on your TRIAD 2's configuration, remote communication is possible via RS485 or Ethernet. In the Windows™ environment, initialize or simply modify the quantities measured, the measurement ranges and the analog outputs on the transducers installed. **TRIADJUST 2** also offers other functions such as **DIAGNOSIS** of your network, instantaneous **DISPLAY** of the electrical quantities and **REAL-TIME RECORDING** of the measurements in an exported file.

You can also print labels indicating the configurations and connections of your products.

## MINIMUM CONFIGURATION

**Platform:** PC

**Operating system:** Windows 2000 or XP

**Processor:** Pentium-compatible

**RAM:** 128 MB

**Hard disk:** 40 GB

**Drive:** CD-ROM

**Communication port:** Local: USB 1.1 minimum  
Remote: RS485 and/or Ethernet

## USER SECTORS



Energy generation



Energy transmission & distribution



Naval applications



### Configuration

- Inputs / Outputs
- Communication
- Connection diagram
- Response time

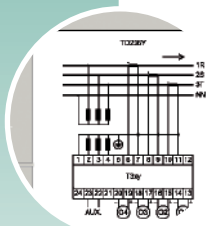

### Diagnosis

- Voltage inputs
- Current inputs
- Cabling
- Phase order
- Analog outputs
- Fresnel

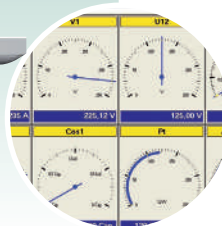

### Display

- Instantaneous quantities (in digital or analog form)

### Recording

- In real time in exported file



- Configuration via optical head, Ethernet or RS485
- Access to all the TRIAD 2 parameters
- Diagnosis of the installation
- Label printing on all types of laser printers

## KIT TRIADJUST 2

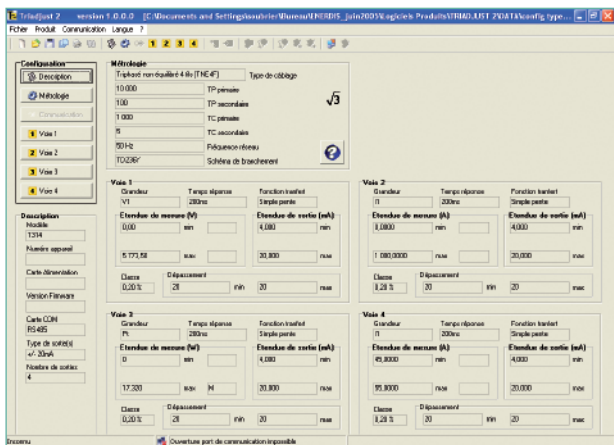

The TRIADJUST 2 configuration kit comprises:

- The TRIADJUST 2 software
- An optical / USB lead
- 30 sheets of blank labels
- A 230 x 185 x 45 mm carrying case

## TO ORDER

Model	Reference
TRIADJUST 2 kit	P01380410

Accessories	Reference
Set of 30 sheets of blank labels	P01380400
Optical/USB lead	P01330403

The TRIADJUST 2 software alone  
CAN BE DOWNLOADED FREE OF CHARGE from the support  
area of the [www.chauvin-arnoux-energy.com](http://www.chauvin-arnoux-energy.com) website

## ASSOCIATED PRODUCTS



### TRIAD 2

Configurable via TRIADJUST 2  
Programmable digital transducers, 1 to 4 analog  
outputs. Configurable accuracy class.  
page 156

## LABELS

A sheet contains two labels, one for the configuration of the inputs/outputs and the other for the programmed connection diagram. The labels can be printed on all types of laser printers.

T314	
<b>Inputs :</b>	50-60 Hz
10 000 V/√3	100 V/√3
1 000 A	5A
<b>AO 1 : V1</b>	[0.20   200 ms   750 Ω
	0 V...5 773.5 V
	4 mA...20 mA
<b>AO 2 : I1</b>	[0.20   200 ms   750 Ω
	0 A...1 000 A
	4 mA...20 mA
<b>AO 3 : Pt</b>	[0.20   200 ms   750 Ω
	0 W...17.32 MW
	4 mA...20 mA
<b>AO 4 : F1</b>	[0.20   200 ms   750 Ω
	45 Hz...55 Hz
	4 mA...20 mA
Made in France	
Reference client / Own reference customer	

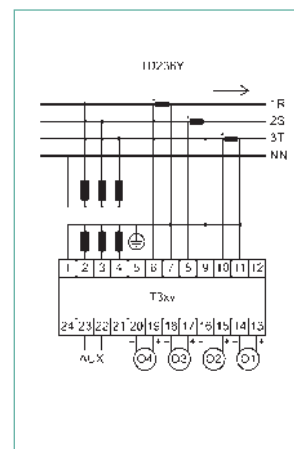

METERS AND  
POWER MONITORS

NETWORK MONITORING  
FROM LV TO HV

CURRENT TRANSFORMERS  
AND SHUNTS

TRANSDUCEURS

PANEL METERS AND  
SYNCHROCOUPLER

AUXILIARY RELAYS

CIVILIAN AND MILITARY  
NAVAL APPLICATIONS

SERVICES AND TRAINING

# T82N RANGE

Nuclear environments. Analog transducers for AC electrical quantities, class 0.5.



## Description

The **T82N** models measure an AC electrical quantity and convert it into a standardized, low-level DC current or voltage signal (e.g. 4...20 mA).

They are normally used in conjunction with analog or digital measuring instruments (panel meters, recorders, etc.), centralized supervision systems (PLCs, SCADA, building management automation systems, etc.) and are also incorporated in measurement and control loops.



## USER SECTORS



Nuclear



Plug-in version with special socket for plate mounting or DIN rail mounting



- Ideal for the requirements of the nuclear market
- Plate-mounted and plug-in versions
- Configurable on request: Input quantities, transfer curve, output signal, etc.

**IAR 1210B**  
RMS AC current

**UAR 1210B**  
RMS AC voltage

**FAR 1210B**  
Frequency

**UCR 1420B**  
DC voltage

**QAR 1232B**  
Reactive power

**PAR 1232B**  
Active power

**JAR 1211B**  
Phase angle

**RCL 1220B**  
Temperature

## ELECTRICAL SPECIFICATIONS

### Inputs

Short-term overload:

- U input: 2 Un during 1s repeated 10 times
- I input: 20 In during 1s repeated 10 times

DC overload :

- U input: 1.2 Un
- I input: 1.2 Un

Frequency:

- 50 Hz (45....55 Hz)
- 60 Hz (55....65 Hz)

### Analog output

- Accuracy: class 0.5 according to IEC 60688 April 2013
- Response time: 120 ms to 260 ms at 95 % of output current
- Current output operating resistance: 20 V / Is
- Influence of operating resistance:  $\pm 0.1$  % from 0  $\Omega$  to max. operating resistance
- Peak-to-peak ripple: 0.2 à 0.4 %

### Auxiliary power supply

Operating range:

- $\pm 10$  % from 100/ $\sqrt{3}$  Vac to 440 Vac
- $\pm 20$  % from 24 to 125 Vdc

Consumption :

- $\leq 3$  VA from 100/ $\sqrt{3}$  to 440 Vac
- $\leq 3$  W from 24 to 125 Vdc

## DIMENSION (IN MM)

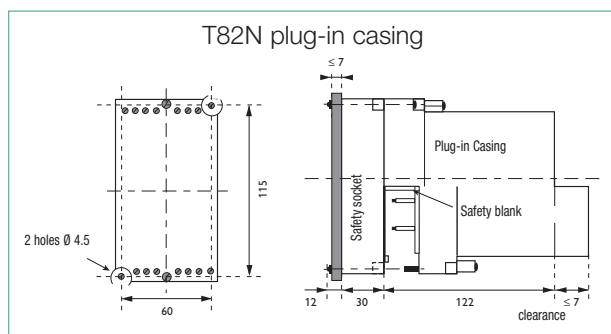
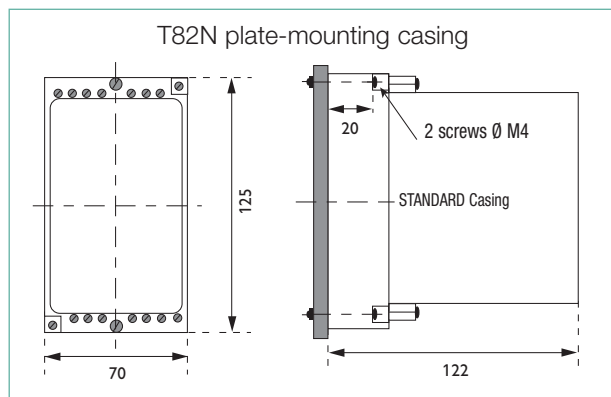

## REFERENCE STANDARDS

- **Electromagnetic compatibility:** 2014/30/CE(CEM) IEC 61326-1 (07/2013)
- **Safety:** 2006/95/CE IEC 61010-1 (01/2011)
- **Metrological:** IEC 60688 (04/2013)
- **Climatic:** IEC 60688 (04/2013)
- **Mechanical:** IEC 60068-2-6 (04/2008) IEC 60068-2-27 (07/2009)

## OPERATING ENVIRONMENT

- **Operating temperature:** -10 to +60 °C
- **Operating humidity:** Up to 95 % to 45 °C
- **Storage temperature:** -25 to +70 °C

## CASINGS

- **Screw connection** terminals, 2 x 2.5 mm<sup>2</sup> or 1 x 6 mm<sup>2</sup>
- **IP20 protection** rating as per IEC 60529
- **Weight :** 0.60 to 0.85 kg (Socket: 0.25 kg)

## MOUNTING ACCESSORIES

- **Connection socket for plug-in Casing**



Model	Socket	
	Type	Reference
UAR 1210B	5	EMBB 4005
IAR 1210B	4	EMBB 4004
PAR 1232B	3	EMBB 4003
QAR 1232B	3	EMBB 4003
FAR 1210B	5	EMBB 4005
JAR 1211B	4	EMBB 4004
UCR 1420B	5	EMBB 4005
RCL 1220B	6	EMBB 4006

- **Mounting on DIN rail for plate-mounting or plug-in Casing**



Model	Reference
Mounting on symmetrical DIN rail	PDIN SYME
Mounting on asymmetrical DIN rail	PDIN ASYM

## ELECTRICAL CONNECTIONS

MS01-7562 or the User's Manuals.



Vac

### ASSOCIATED PRODUCTS

#### Normeurope analog panel meters



Round / square barrel  
For viewing an instantaneous and variable quantity.  
page 222

#### Sockets



For plug-in casings  
page 173

#### Mounting on DIN rail



Plate-mounting or plug-in  
page 173

### RMS AC VOLTAGE

Model	UAR 1210 B	
<b>Transfer curve</b>		
Linear	■	
<b>Casing</b>		
Fixed / plate-mounting	0.7 kg	
<b>Measurement input</b>		
Voltage Un	Direct or on VT: "100/√3" "110/√3" "115/√3" "120/√3" "132/√3" "90" "100" "110" "115" "120" "127" "132" "138" "180" "220" "250" "300" "360" "380 Vac	
Frequency Fn	50 Hz ±5 Hz and 60 Hz ±5 Hz	
Measurement range 0...Xmax	0...1.25 Un	
Consumption	1kΩ/ V or 0.4 VA at 400 Vac	
<b>Analog output</b>		
Current	0...Ymax	"0/1 mA" "0/2.5 mA" "0/5 mA" "0/10 mA" "0/20 mA"
	Ymin...Ymax	"1/5 mA" "2/10 mA" "4/20 mA"
Voltage	0...Ymax	"0/1 V" "0/5 V" "0/10 V"
	Ymin...Ymax	"1/5 V" "2/10 V"
Accuracy	0.5 %	
<b>Auxiliary supply</b>		
Alternating current	"100/√3 Vac" "110/√3 Vac" "115/√3 Vac" "100 Vac" "110 Vac" "115 Vac" "127 Vac" "220 Vac" "230 Vac" "240 Vac"	
Direct current	"24 Vdc" "48 Vdc" "110 Vdc" "125 Vdc"	
<b>Casing protection rating</b>		
Fixed / plate-mounting	IP20	

### CUSTOMIZED PRODUCT

	Model	Casing	Direct Un or on VT	Measurement range	Fn	Analog output	Auxiliary supply	Protection	Tropicalization
Example	UAR 1210 B	Fixed	Direct 100 Vac	0...120 Vac	50 Hz	4-20 mA	220 Vac	IP 20	☑



Iac

### ASSOCIATED PRODUCTS



#### Normeurope analog panel meters

Round / square barrel  
For viewing an instantaneous and variable quantity.  
page 222



#### Sockets

For plug-in casings  
page 173



#### Mounting on DIN rail

Plate-mounting or plug-in  
page 173

### RMS AC CURRENT

Model	IAR 1210 B
<b>Transfer curve</b>	
Linear	■
<b>Casing</b>	
Fixed / plate-mounting	0.7 kg
<b>Measurement input</b>	
Current In	Direct 0.5 to 10 A or on CT 1/5 A
Frequency Fn	50 Hz ±5 Hz and 60 Hz ±5 Hz
Measurement range 0...Xmax	0 to In and 0 to 1.3 In if CT present
Consumption	≤ 0.2 VA
<b>Analog output</b>	
Current	0...Ymax "0/1 mA" "0/2.5 mA" "0/5 mA" "0/10 mA" "0/20 mA"
	Ymin...Ymax "1/5 mA" "2/10 mA" "4/20 mA"
Voltage	0...Ymax "0/1 V" "0/5 V" "0/10 V"
	Ymin...Ymax "1/5 V" "2/10 V"
Accuracy	0.5 %
<b>Auxiliary supply</b>	
Alternating current	"100/√3 Vac" "110/√3 Vac" "115/√3 Vac" "100 Vac" "110 Vac" "115 Vac" "127 Vac" "220 Vac" "230 Vac" "240 Vac"
Direct current	"24 Vdc" "48 Vdc" "110 Vdc" "125 Vdc"
<b>Casing protection rating</b>	
Fixed / plate-mounting	IP20

### CUSTOMIZED PRODUCT

	Model	Casing	Direct In or on CT	Measurement range	Fn	Analog output	Auxiliary supply	Protection	Tropicalization
Example	IAR 1210 B	Fixed	1000/5 A	0...1300 A	50 Hz	4-20 mA	48 Vdc	IP 20	<input checked="" type="checkbox"/>



P

### ASSOCIATED PRODUCTS

#### Normeurope analog panel meters



Round / square barrel  
For viewing an instantaneous and variable quantity.  
page 222

#### Sockets



For plug-in casings  
page 173

#### Mounting on DIN rail



Plate-mounting or plug-in  
page 173

## ACTIVE POWER

Model	PAR 1232 B	
<b>Network + connections</b>		
Balanced three-phase - 3 wires	■	
Unbalanced three-phase - 3 / 4 wires	■	
<b>Transfer curve</b>		
Linear	■	
<b>Casing</b>		
Fixed / plate-mounting	0.85 kg	
<b>Measurement input</b>		
Current In	Direct or on CT: "1" "5"	
Ph-N voltage Un	Direct or on VT: "57,73" "63,51" "66,4" "230"	
Ph-Ph voltage Un	Direct or on VT: "100" "110" "115" "120" "127" "230" "240" "380" "400"	
Frequency Fn	50 Hz ±5 Hz and 60 Hz ±5 Hz	
Measurement range 0...Xmax	±1.35 ≥Sn <sup>(1)</sup> ≥ ±0.50	
Consumption	I input: ≤ 0.2 VA ; U input: ≥ 500 Ω / V	
<b>Analog output</b>		
Current	0...Ymax	"0/1 mA" "0/2.5 mA" "0/5 mA" "0/10 mA" "0/20 mA"
	Ymin...Ymax	"1/5 mA" "2/10 mA" "4/20 mA" "1/3/5 mA" "2/6/10 mA" "4/12/20 mA" "-1/0/1 mA" "-2.5/0/2.5 mA" "-5/0/5 mA" "-10/0/10 mA" "-20/0/20 mA"
Voltage	0...Ymax	"0/1 V" "0/5 V" "0/10 V"
	Ymin...Ymax	"1/5V" "2/10V" "-1/0/1V" "-5/0/5V" "-10/0/10 V"
Accuracy	0.5 %	
<b>Auxiliary supply</b>		
Alternating current	"100/√3 Vac" "110/√3 Vac" "115/√3 Vac" "100 Vac" "110 Vac" "115 Vac" "127 Vac" "220 Vac" "230 Vac" "240 Vac"	
Direct current	"24 Vdc" "48 Vdc" "110 Vdc" "125 Vdc"	
Self-powered	For voltages "100 Vac" "110 Vac" "115 Vac" "120 Vac" "127 Vac" "230 Vac" "240 Vac"	
<b>Casing protection rating</b>		
Fixed / plate-mounting	IP20	

(1) Sn = √ x I x cos φ (single-phase network) Sn = 3 x √ x I x cos φ (Balanced three-phase, Unbalanced three-phase 4 wires)  
Sn = √3 x U x I x cos φ (Network TE, TNE 3 fils)

★ Parameters to be specified when ordering

## CUSTOMIZED PRODUCT

★	Model	Network	Casing	Direct In or on CT	Direct Un or on VT	Measurement range	Fn	Analog output	Auxiliary supply	Protection	Tropicalization
Example	PAR 1232 B	Unbal. 3ph 4 wires	Fixed	CT 1000/ 5 A	VT 20 kV/ 100 V	0... 120 Vac	50 Hz	4-20 mA	220 Vac	IP 20	<input checked="" type="checkbox"/>



Q

### ASSOCIATED PRODUCTS



#### Normeurope analog panel meters

Round / square barrel  
For viewing an instantaneous and variable quantity.  
page 222



#### Sockets

For plug-in casings  
page 173



#### Mounting on DIN rail

Plate-mounting or plug-in  
page 173

### REACTIVE POWER

<b>Model</b>		QAR 1232 B
<b>Network + connections</b>		
Unbalanced three-phase - 3 / 4 wires		
<b>Transfer curve</b>		
Linear		
<b>Casing</b>		
Fixed / plate-mounting		0.85 kg
<b>Measurement input</b>		
<b>Current In</b>		Direct or on CT: "1" "5"
<b>Ph-N voltage Un</b>		Direct or on VT "57.73" "63.51" "66.4" "230"
<b>Ph-Ph voltage Un</b>		Direct or on VT "100" "110" "115" "120" "127" "230" "240" "380" "400"
<b>Frequency Fn</b>		50 Hz ±5 Hz and 60 Hz ±5 Hz
<b>Measurement range 0...Xmax</b>		±1.35 ≥Sn <sup>(1)</sup> ≥ ±0.50
<b>Consumption</b>		I input: ≤ 0.2 VA ; U input: ≥ 500 Ω/ V
<b>Analog output</b>		
<b>Current</b>	<b>0...Ymax</b>	"0/1 mA" "0/2.5 mA" "0/5 mA" "0/10 mA" "0/20 mA"
	<b>Ymin...Ymax</b>	"1/5 mA" "2/10 mA" "4/20 mA" "1/3/5 mA" "2/6/10 mA" "4/12/20 mA" "-1/0/1 mA" "-2.5/0/2.5 mA" "-5/0/5 mA" "-10/0/10 mA" "-20/0/20 mA"
<b>Voltage</b>	<b>0...Ymax</b>	"0/1 V" "0/5 V" "0/10 V"
	<b>Ymin...Ymax</b>	"1/5V" "2/10V" "-1/0/1V" "-5/0/5V" "-10/0/10 V"
<b>Accuracy</b>		0.5 %
<b>Auxiliary supply</b>		
<b>Alternating current</b>		"100/√3 Vac" "110/√3 Vac" "115/√3 Vac" "100 Vac" "110 Vac" "115 Vac" "127 Vac" "220 Vac" "230 Vac" "240 Vac"
<b>Direct current</b>		"24 Vdc" "48 Vdc" "110 Vdc" "125 Vdc"
<b>Self-powered</b>		For voltages "100 Vac" "110 Vac" "115 Vac" "120 Vac" "127 Vac" "230 Vac" "240 Vac"
<b>Casing protection rating</b>		
Fixed / plate-mounting		IP20

(1) Sn = √ x I x cos φ (single-phase network) Sn = 3 x √ x I x cos φ (Balanced three-phase, Unbalanced three-phase 4 wires)  
Sn = √3 x U x I x cos φ (Balanced three-phase, Unbalanced three-phase 3 wires)

★ Parameters to be specified when ordering

### CUSTOMIZED PRODUCT

★	Model	Network	Casing	Direct In or on CT	Direct Un or on VT	Measurement range	Fn	Analog output	Auxiliary supply	Protection	Tropicalization
Example	QAR 1232 B	Unbal. 3ph 4 wires	Fixed	CT 1000/ 5 A	VT 20 kV/ 100 V	0... 2.77 MW	50 Hz	4...20 mA	220 Vac	IP 20	✓



F

### ASSOCIATED PRODUCTS



#### Normeurope analog panel meters

Round / square barrel  
For viewing an instantaneous and variable quantity.  
page 222



#### Sockets

For plug-in casings  
page 173



#### Mounting on DIN rail

Plate-mounting or plug-in  
page 173

### FREQUENCY

Model	FAR 1210 B	
Measurement	Effective value	
Measurement type	Effective value	
Input type	■	
Casing		
Fixed / plate-mounting	0.7 kg	
Measurement input		
Voltage Un	Direct or on VT : "100/√3" "110/√3" "115/√3" "100" "110" "115" "120" "127" "230" "240" "380"	
Measurement range Xmin...Xmax	"45/55 Hz" "48/52 Hz" "49/51 Hz" "55/65 Hz" "58/62 Hz" "59/61 Hz"	
Consumption	1 k Ω / V	
Analog output		
Transfer curve	Linear	
Current	0...Ymax	"0/1 mA" "0/2.5 mA" "0/5 mA" "0/10 mA" "0/20 mA"
	Ymin...Ymax	"1/5 mA" "2/10 mA" "4/20 mA" "-1/0/1 mA" "-2.5/0/2.5 mA" "-5/0/5 mA" "-10/0/10 mA" "-20/0/20 mA"
Voltage	0...Ymax	"0/1 V" "0/5 V" "0/10 V"
	Ymin...Ymax	"1/5V" "2/10V" "-1/0/1V" "-5/0/5V" "-10/0/10 V"
Accuracy	0.5 %	
Auxiliary supply		
Alternating current	"100/√3 Vac" "110/√3 Vac" "115/√3 Vac" "100 Vac" "110 Vac" "115 Vac" "127 Vac" "220 Vac" "230 Vac" "240 Vac"	
Direct current	"24 Vdc" "48 Vdc" "110 Vdc" "125 Vdc"	
Self-powered	■	
Casing protection rating		
Fixed / plate-mounting	IP20	

★ Parameters to be specified when ordering

### CUSTOMIZED PRODUCT

★	Model	Casing	Direct Un or on VT	Measurement range	Analog output	Auxiliary supply	Protection	Tropicalization
Example	FAR 1210 B	Fixed	Direct 100 Vac	45...55 Hz	4...20 mA	220 Vac	IP 20	☑



PF

### ASSOCIATED PRODUCTS



#### Normeurope analog panel meters

Round / square barrel  
For viewing an instantaneous and variable quantity.  
page 222



#### Sockets

For plug-in casings  
page 173



#### Mounting on DIN rail

Plate-mounting or plug-in  
page 173

### PHASE ANGLE

Model	JAR 1211 B
<b>Network</b>	
Single-phase	■
<b>Casing</b>	
Fixed/plug-in	0.7 kg
<b>Measurement input</b>	
In Current	Direct or on CT: "1" "5" "10 A"
Un Voltage	Direct or on VT : "100/√3" "110/√3" "115/√3" "100" "110" "115" "127" "230" "240" "380" "400"
Fn Frequency	50 Hz, 60 Hz
Measurement range 0...Xmax	±1.35 ≥Sn <sup>(1)</sup> ≥ ±0.50
Consumption	Input I: ≤ 0.3 VA; Input U: ≥ 1 kΩ/V
<b>Analog output</b>	Linear
Current	0...Ymax "0/1 mA" "0/2 mA" "0/2.5 mA" "0/5 mA" "0/10 mA" "0/20mA"
	Ymin...Ymax "4/20 mA"
Voltage	0...Ymax "0/1 V" "0/5 V" "0/10 V"
	Ymin...Ymax "1/5V" "2/10V"
Accuracy	0.5 %
<b>Auxiliary power supply</b>	
Alternating current	"100/√3 Vac" "110/√3 Vac" "115/√3 Vac" "100 Vac" "110 Vac" "115 Vac" "127 Vac" "220 Vac" "230 Vac" "240 Vac"
Direct current	"24 Vdc" "48 Vdc" "110 Vdc" "125 Vdc"
Self-powered	■
<b>Protection for casing</b>	
Fixed/plug-in	IP20

★ Parameters to be specified when ordering

### CUSTOMIZED PRODUCT

★	Model	Casing	In Direct or on CT	Un Direct or on VT	Measurement range	Analog output	Auxiliary power supply	Protection	Tropicalization
Example	JAR 1211 B	Fixed	CT 1000/5 A	Direct : 100 Vac	0.5 LEAD/1/ 0.5 LAG	4/20 mA	220 Vac	IP 20	<input checked="" type="checkbox"/>



Vdc

## ASSOCIATED PRODUCTS

### Normeurope analog panel meters



Round / square barrel  
For viewing an instantaneous and variable quantity.  
page 222



### Sockets

For plug-in casings  
page 173



### Mounting on DIN rail

Plate-mounting or plug-in  
page 173

## VOLTAGE DC

Model	UCR 1220B/1420B		
<b>Measurement</b>			
DC voltage	■		
<b>Transfer curve</b>			
Linear	■		
<b>Casing</b>			
Fixed	0.7 kg		
Plug-in	0.7 kg		
<b>Voltage input</b>			
Voltage Un	5mV ≤ Un ≤ 300V		
Measurement range 0 ... Xmax	5mV ... 300V		
	Umax ≤ 0.3V : 1MΩ		
Input resistance	Umax ≤ 20V : 30kΩ + (10kΩ / Umax)		
	Umax ≤ 200V : Umax * 10kΩ		
	Umax > 200V : 2.5MΩ		
<b>Analog output</b>			
Current	0...Ymax	"0/1 mA" "0/2.5 mA" "0/5 mA" "0/10 mA" "0/20 mA"	
	Ymin...Ymax	"0/1 mA" "0/2.5 mA" "0/5 mA" "0/10 mA" "0/20 mA"	
Voltage	0...Ymax	"0/1 V" "0/5 V" "0/10 V"	
	Ymin...Ymax	"1/5 V" "2/10 V"	
Accuracy	0.5 %		
<b>Auxiliary power supply</b>			
Alternating current	""100/√3 VAC"" ""110/√3 VAC"" ""115/√3 VAC"" ""100 VAC"" ""110 VAC"" ""115 VAC"" ""127 VAC"" ""220 VAC"" ""230 VAC"" ""240 VAC""		
Direct current	"24 VDC" "48 VDC" "110 VDC" "125 VDC"		
<b>Casing protection</b>			
Fixed	IP20		
Plug-in	IP20		

★ Parameters to indicate when ordering

## CUSTOMIZED PRODUCT

★	Model	Casing	Measurement range	Analog output	Auxiliary power supply	Ingress protection	Tropicalization
Example	UCR1420B	Fixed	0...150Vdc	4...20 mA	48Vdc	IP 20	☑

## ASSOCIATED PRODUCTS



### Normeurope analog panel meters

Round / square barrel  
For viewing an instantaneous and variable quantity.  
page 222



### Sockets

For plug-in casings  
page 173



### Mounting on DIN rail

Plate-mounting or plug-in  
page 173



T°C



Thermocouple/probe:  
Pyrocontrole Catalog

## TEMPERATURE

Model	RCL 1220B		
<b>Measurement</b>			
Temperature	■		
<b>Transfer curve</b>			
Linear	■		
<b>Casing</b>			
Fixed	0.7 kg		
Plug-in	0.7 kg		
<b>Measurement input</b>			
Type	Platinum		Copper
Thermocouple break safety	Max output or Min output		
Mounting	2, 3 or 4 wires		
Measurement range Xmin ... Xmax	0 ... 500°C		0 ... 200°C
Current in probe	2 mA		3 mA
Line resistance	0.5%		
<b>Analog output</b>			
Current	0...Ymax	"0/1 mA" "0/2.5 mA" "0/5 mA" "0/10 mA" "0/20 mA"	
	Ymin...Ymax	"1/5 mA" "2/10 mA" "4/20 mA"	
Voltage	0...Ymax	"0/1 V" "0/5 V" "0/10 V"	
	Ymin...Ymax	"1/5 V" "2/10 V"	
Accuracy	0.5 %		
<b>Auxiliary power supply</b>			
Alternating current	"100/√3 VAC" "110/√3 VAC" "115/√3 VAC" "100 VAC" "110 VAC" "115 VAC" "127 VAC" "220 VAC" "230 VAC" "240 VAC"		
Direct current	"24 VDC" "48 VDC" "110 VDC" "125 VDC"		
<b>Casing protection</b>			
Fixed	IP20		
Plug-in	IP20		

## CUSTOMIZED PRODUCT

	Model	Casing	Sensor type	Safety	Mounting	Line resistance	Analog output	Auxiliary power supply	Ingress protection	Tropicalization
Example	RCL1220B	Fixed	Plate	Max output	3 wires	2 Ω	4...20 mA	48Vdc	IP 20	<input checked="" type="checkbox"/>



Idc

### ASSOCIATED PRODUCTS

#### Normeurope analog panel meters



Round / square barrel  
For viewing an instantaneous and variable quantity.  
page 222

#### Sockets



For plug-in casings  
page 173

#### Mounting on DIN rail



Plate-mounting or plug-in  
page 173

## CURRENT DC

Model	ICR 1220B/1420B	
<b>Measurement</b>		
DC current	■	
<b>Transfer curve</b>		
Lineaire	■	
<b>Boîtier</b>		
Fixe	0,7 kg	
Embrochable	0,7 kg	
<b>Measurement input</b>		
Current In	5 µA ≤ In ≤ 100 mA	
Measurement range 0 ... Xmax	0... ± In	
Input resistance	0,1 V/In	
<b>Analog output</b>		
Current	0...Ymax	"0/1 mA" "0/2.5 mA" "0/5 mA" "0/10 mA" "0/20 mA"
	Ymin...Ymax	"1/5 mA" "2/10 mA" "20 mA"
Tension	0...Ymax	"0/1 V" "0/5 V" "0/10 V"
	Ymin...Ymax	"1/5 V" "2/10 V"
Précision	0,5 %	
<b>Auxiliary power supply</b>		
Alternating current	""100/√3 VAC"" ""110/√3 VAC"" ""115/√3 VAC"" ""100 VAC"" ""110 VAC"" ""115 VAC"" ""127 VAC"" ""220 VAC"" ""230 VAC"" ""240 VAC""	
Direct current	"24 VDC" "48 VDC" "110 VDC" "125 VDC"	
<b>Casing protection</b>		
Fixed	IP20	
Plug-in	IP20	

★ Parameters to indicate when ordering

## CUSTOMIZED PRODUCT

★	Model	Casing	Measurement range	Analog output	Auxiliary power supply	Ingress protection	Tropicalization
Example	ICR 1420B	Fixed	4... 20 mA	4...20 mA	48Vdc	IP 20	☑



# ELINK 61850

IEC 61850 network communication gateway for TRIAD 2 transducers and ENERIUM power monitors.

## USER SECTORS



Energy generation



Energy transmission & distribution



Naval applications



IEC 61850 server Ethernet port



2 x RS485 ports (Modbus/jbus RTU) in master mode

## Description

The ELINK 61850 network gateway enables communication between ENERIUM power monitors and TRIAD 2 transducers via the IEC 61850 protocol.

In this way, the ENERIUM and TRIAD products can be seen as native IEC 61850 products by any IEC 61850 supervision system or SCADA / RTU client PLC.

- **Independent:** ELINK 61850 allows IEC 61850 communication without calling your choice or qualification of a Chauvin Arnoux Energy measurement solution into question
- **Installation upgrading:** ELINK 61850 interfaces with equipment already in place and allows you to modernize your installation to transition towards digital stations
- **Complete:** All the electrical measurements from the Chauvin Arnoux Energy measuring equipment are carried by the IEC 61850 communication protocol:
  - Instantaneous measurements for TRIAD 2
  - Instantaneous measurements, min/max/avg, energy and energy quality for ENERIUM
- **Customizable:** the teams at Chauvin Arnoux Energy respond quickly to offer solutions allowing you to adapt ELINK 61850 to fit your configurations



- **Communication**
  - IEC 61850 server – Edition 2
  - Modbus RS485 master
- **Invisible: TRIAD 2 and ENERIUM seen as native products**
- **Simple implementation via web pages**
- **High-performance: up to 20 slave units**

## ELECTRICAL SPECIFICATIONS

Auxiliary power supply	
AC network	80 to 265 Vac - 10 VA / 42.5 to 69 Hz
DC network	80 to 265 Vdc - 7 W
Outputs	
Power reserve	2.5 seconds at 230 Vac

## COMMUNICATION

IEC 61850 protocol	
Parts	IEC 61850-1, IEC 61850-5, IEC 61850-7
Logical nodes supported	MMXU, MMXN, MSTA, MMTR (Triad2/ Enerium) MHAI, MHAN (Enerium)
Ethernet port	RJ45 - 8 contacts / 10 - 100 baseT
RS485A and RS485B ports	Type : Independent RS485 - 2 isolated wires Protocol: Modbus RTU mode Operation: Master mode Half-duplex speed: 300 to 115.200 bauds

## MECHANICAL SPECIFICATIONS

Weight	560 g
Mounting	On DIN rail
Connection	Screw terminal block 6 mm <sup>2</sup> single-strand wire- 4 mm <sup>2</sup> multi-strand wire
Cable cross-section	
Dimensions	120.5 x 120 x 81 mm (W x L x H)

## TO ORDER

Model	Reference
ELINK 61850	P01 3808 50

## ASSOCIATED PRODUCTS



### TRIAD 2

Digital transducers  
1 to 4 analog outputs. Class 0.1.  
page 156



### ENERIUM

Power meters  
Multi-energy, qualimetry.  
page 64

## ENVIRONMENTAL CONSTRAINTS

Operating temperature	-10 °C to +55 °C
Storage temperature	-25 °C to +70 °C
Ingress protection	IP20
Pollution degree	2
Installation category	III
Safety standard	IEC 61010
Electromagnetic standards	IEC 61000-4-2/3/4/5/6/8/11/12/18 - CISPR22 IEC 61000-6-5 (Zone 2)

## ELECTRICAL CONNECTIONS





NETWORK SUPERVISION AND PHYSICAL MEASUREMENT

# PANEL METERS

AND

# SYNCHROCOUPLER



- 188 DIGITAL PANEL METERS
- 188 OVERVIEW OF THE RANGE
- 189 SELECTION GUIDE
- 204 SYNCHRONIZATION UNIT
- 208 ANALOG PANEL METERS
- 208 OVERVIEW OF THE RANGE
- 211 SELECTION GUIDE
- 236 HOUR METERS

METERS AND  
POWER MONITORS

NETWORK MONITORING  
FROM LV TO HV

CURRENT TRANSFORMERS  
AND SHUNTS

TRANSDUCERS

PANEL METERS AND  
SYNCHROCOUPLER

AUXILIARY RELAYS

CIVILIAN AND MILITARY  
NAVAL APPLICATIONS

SERVICES AND TRAINING

# DIGITAL PANEL METERS

## AND SYNCHROCOUPLER

### μDIGI1 ET μDIGI2 RANGES

---



**μDIGI1**  
24 x 48 mm-format programmable panel meters for industrial use.  
page 192



**μDIGI2**  
48 x 96 mm-format programmable panel meters for industrial use.  
page 196

### CA 2150 RANGE

---



**CA 2150**  
48 x 96 mm-format programmable digital panel meters for all types of industrial applications  
page 200

### SYNCHRONIZATION UNIT

---



**Synchrocoupleur**  
Synchronization units for LV networks.  
page 204

# SELECTION GUIDE

## USER SECTORS



Industry



Energy generation



Naval applications

### μDIGI1/μDIGI2 range

page 192



page 196



### CA 2150 range

page 200



		μDIGI1	μDIGI2	CA 2150
<b>Front panel format (mm)</b>		24 x 48	48 x 96	48 x 96
<b>Display range (in counts)</b>		-1999/+9999	-1999/+9999	-19999/+19999
<b>Measurement functions</b>	<b>AC ammeter</b>	μDIGI1 E	μDIGI2 E	CA 2150-E
	<b>AC voltmeter</b>	μDIGI1 E	μDIGI2 E	CA 2150-E
	<b>Frequency meter</b>			CA 2150-D
	<b>DC ammeter</b>	μDIGI1 E	μDIGI2 E	CA 2150-E
	<b>DC voltmeter</b>	μDIGI1 E	μDIGI2 E	CA 2150-E
	<b>Process signals</b>	μDIGI P/LP	μDIGI2 P	CA 2150-M
	<b>Thermocouple thermometer</b>		μDIGI2 P	CA 2150-M
	<b>Pt 100 thermometer</b>		μDIGI2 P	CA 2150-M
	<b>Ohmmeter</b>		μDIGI2 P	
	<b>Tachometer</b>			CA 2150-D
	<b>Meter</b>			CA 2150-D
	<b>Chronometer</b>			CA 2150-D
	<b>Load cell</b>			CA 2150-M
	<b>Potentiometer</b>		μDIGI2 P	CA 2150-M
<b>Special functions</b>	<b>MIN/MAX</b>		μDIGI2 E/P	CA 2150-E/D/M
<b>Output(s)</b>	<b>Analog output</b>			Option
	<b>RS232 output</b>			Option
	<b>RS485 output</b>			Option
	<b>Threshold output(s)</b>		Option	Option

### User-programmable

<b>Strengths</b>	Economical programmable range for industrial use	Programmable range for universal use
------------------	--	--------------------------------------

METERS AND POWER MONITORS

NETWORK MONITORING FROM LV TO HV

CURRENT TRANSFORMERS AND SHUNTS

TRANSDUCERS

PANEL METERS AND SYNCHROCOUPLER

AUXILIARY RELAYS

CIVILIAN AND MILITARY NAVAL APPLICATIONS

SERVICES AND TRAINING

# INFO & ADVICE



Digital panel meters are used to display an analog value clearly and precisely. The digital processing enables these instruments to display different values, and allows connection to external measurement or supervision systems.

Several criteria influence the choice of a digital panel meter, the first being the scale or the measurement range, defined by the variation range of the signal to be measured.

## THE RESOLUTION

The number of display counts defines the resolution of the panel meter. The resolution is the necessary variation of the measurement signal required to vary the reading by one point. For a given rating, the greater the display capacity, the better the resolution.

For example, for an 11-bit (2,000-counts) panel meter with a 20 V range, the resolution is 10 mV.

However, for industrial applications, it is not always wise to choose a digital panel meter of too high resolution. The measurement signal may be subject to noise interference, resulting in permanent instability of the low-weighted displays (units) on the panel meter.

## ACCURACY

Accuracy, which is not to be confused with resolution, defines the maximum variation between the instrument reading and the true value of the signal measured. It is expressed as follows:  $E = x\%$  of the reading  $\pm y$  counts. The first term depends on the conversion method and the precision of the components, while the second depends on the various drift, dispersion, fluctuation and noise factors that can affect the instrument.

## FORMAT

The format and weight of the instrument must also be taken into account, as they affect the sizing of electrical cabinets. The format 48 x 96 (DIN standard 43700) is the industrial standard.

## DISPLAY

The visibility of panel meter display characters is directly linked to the light difference between the digits and the screen background. LEDs, LCDs and backlit LCDs offer different levels of readability. LED technology, used on most of the Chauvin Arnoux Energy range of digital panel meters, offers the best display contrast.

A choice of red, green and amber colors also ensures they are easy to read.



## DISPLAY ONLY OR MULTIFUNCTION PRODUCTS? \_\_\_\_\_

Panel meters are increasingly universal, and must be able to display both strong signals, such as the voltage of a network, and weak signals such as process signals.

Instruments with multiple inputs, ratings and outputs are increasingly equipped with digital interfaces (RS232, RS485) for remote communication, analog outputs, and relay or alarm interfaces for connection to logic controllers.

## NUMBER OF DIGITS AND DISPLAY COUNTS \_\_\_\_\_

The display of a digital panel meter is characterized by the number of digits. We speak, for example, of 3 1/2 digit or 4 3/4 digit panel meters.

A full digit has 10 possible states, in other words all values between 0 and 9.

A 1/2 digit has a maximum value of 1 and is capable of 2 states: 0 and 1.

A 3/4 digit can display a maximum value equal to 3 and has 4 states: 0, 1, 2, 3.

We can therefore expect a 3 1/2 digit panel meter to be capable of counting up to 2,000 (0 to 1,999), and a 4 3/4 digit panel meter to be capable of counting up to 40,000 (0 to 39,999). For this, the real display range of the apparatus must not be inferior.

## HOW TO GET THE BEST OUT OF YOUR PANEL METER.

### ENVIRONMENT \_\_\_\_\_

Digital panel meters, in general, are intended for indoor use, their electronic circuit being sensitive to difficult climatic environments (in contrast to analog panel meters, which are suitable for both indoor and outdoor use). They must also support emissions induced and emitted by the electrical equipment.

### MAINTENANCE \_\_\_\_\_

Unlike the analog panel meter, the digital panel meter accepts low currents (maximum 600 V and 5 A). It therefore requires minimal precautions for the use of currents and voltages

# μDIGI1 RANGE

24 x 48 mm programmable panel meters for industrial use.



## USER SECTORS



Industry



Energy generation



Naval applications



Plug-in connectors for quick and easy connection



Display with 4 levels of brightness

## PROGRAMMING

Quick and easy:

- **Local** programming using the 3 keys of the keypad. Only the instructions required for the application are shown. No mistakes are possible. Access to programming can be protected on all the instruments.



- Simple programming using 3 keys
- Instant mounting without tools
- Compact dimensions

**μDIGI1-LP**

4-20mA process signal

- **Input:** 4-20 mA
- **Display range:**  
-1 999... 9 999

**μDIGI1-P**

U/I process signal

- **Input:**  
-10... +10 Vdc  
-20... +20 Vdc  
-200... +200 Vdc (1 MΩ)  
-100... +100 mVdc (100 MΩ)  
-20... +20 mAdc (12,1 Ω)
- **Display range:**  
-1 999... 9 999

**μDIGI1-E**

U/I voltage and current

- **Input:**  
600 Vac  
100 Vac  
-199,9... +600 Vdc  
-100... +100 Vdc (3 MΩ)  
5 Aac  
1 Aac  
-1,999... +5 Adc  
-1... +1 Adc (14 mΩ)  
40 Hz... 1 KHz
- **Display range:**  
-1 999... 9 999 (dc)  
- 0... 9 999 (ac)

**TO ORDER**

Power supply	Reference
Self-powered (active loop)	P01 330 000

Power supply	Reference
85 - 265 Vac & 100 - 300 Vdc	P01 330 031
22 - 53 Vac & 10.5 - 70 Vdc	P01 330 032

Power supply	Reference
85 - 265 Vac & 100 - 300 Vdc	P01 330 011
22 - 53 Vac & 10.5 - 70 Vdc	P01 330 012

**ASSOCIATED PRODUCTS****Current transformers & shunts**

Tertiary, industrial, tariff  
5 to 5,000 A.  
page 120

## DISPLAY

	<b>μDIGI1-LP</b>	<b>μDIGI1-P</b>	<b>μDIGI1-E</b>
<b>Measurement rate</b>	62/s		
<b>Display range</b>	-1 999... 9 999	-1 999... 9 999	-1 999... 9 999 (dc) 0... 9 999 (ac)
<b>7-segment red LED display</b>	Height 10 mm		
<b>Reading</b>	4 digits		
<b>Polarity</b>	Automatic		
<b>Overrun</b>	OVE display		
<b>Decimal position</b>	Programmable using software		

## MECHANICAL SPECIFICATIONS

<b>Material</b>	Polycarbonate as per UL94 V-O
<b>Weight</b>	60 g - 40 g (μDIGI1-LP)
<b>Protection rating</b>	Front panel IP 65
<b>Mounting</b>	On panel with self-locking strap

## ENVIRONMENT

<b>Storage temperature</b>	-10 °C to +60 °C
<b>Storage temperature</b>	-25 °C to +85 °C
<b>Relative humidity</b>	< 95 % at +40 °C
<b>Max. altitude</b>	2 000 m

## POWER SUPPLY

<b>High level</b>	85/265 Vac 50 / 60 Hz - 100/300 Vdc
<b>Low level</b>	22/53 Vac 50 / 60 Hz - 10.5/70 Vdc
<b>Consumption</b>	≤ 2.2 W

## STANDARDS

Insulation – dielectric strength: EN 611010-1 (category II installation)

EMC – immunity/emission: EN 61000-4-2, EN 61000-4-3, EN 61000-4-4 / EN 55022  
(EN 61000-4-6 for  $\mu$ DIGI1-LP – EN 61000-4-5)

## DIMENSIONS (IN MM)

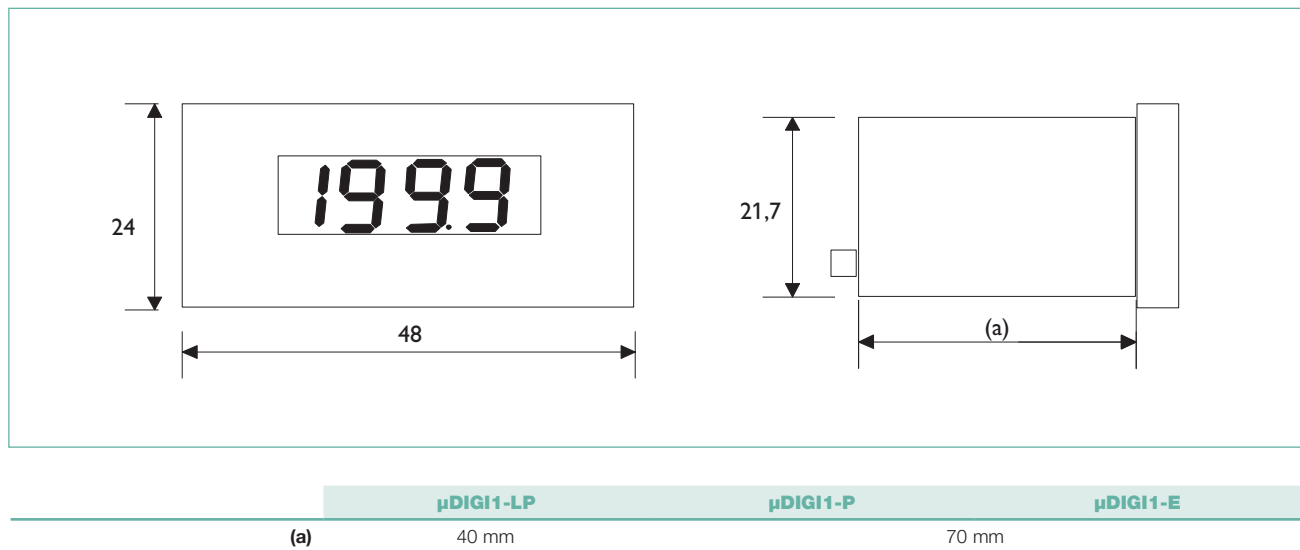

## (A) PANEL DRILLING SPECIFICATIONS (IN MM)

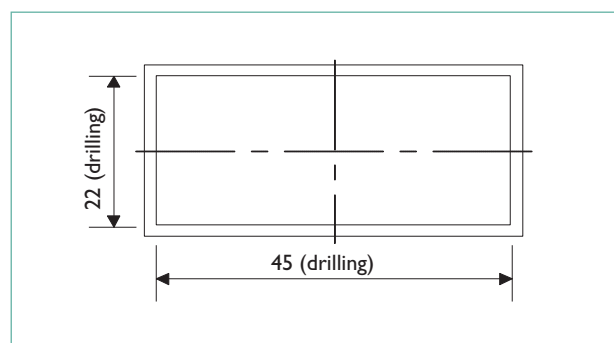

# μDIGI2 RANGE

Programmable panel meters in 48 x 96 mm format for industrial applications.



## DESCRIPTION

- Display on 4 digits
- MIN/MAX values stored
- Power supply with large dynamic range
- Programming on front panel

## USER SECTORS



Industry



Energy generation



Naval applications



Simple programming with 3 keys on front panel

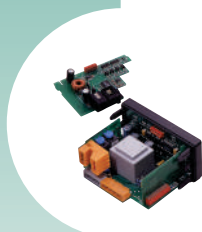

Easy installation of option boards

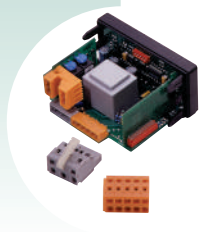

Quick connection using plug-in connectors



- Economical single-function range
- Instant fitting without tools

## OPTION BOARD

	Reference
<b>2-relay alarm board</b>	P01 3193 01

## μDIGI2 E

- **DC voltage:**  
600 V  
200 V  
20 V
- **DC current:**  
5 A  
1 A  
100 mV  
60 mV
- **AC voltage:**  
600 V  
200 V  
20 V
- **AC current:**  
5 A  
1 A  
100 mV  
60 mV

## μDIGI2 P

- **Process:**  
±20 mA  
10 V  
200 V  
dynamo-tachometer
- **Temperature:**  
Thermocouple J  
Thermocouple K  
Thermocouple T  
Thermocouple N  
Pt 100  
Pt 1000
- **Potentiometer:**  
100 Ω to 100 kΩ
- **Resistance:**  
1 kΩ  
10 kΩ  
50 kΩ

## TO ORDER

Power supply	Reference
20/265 Vac - 11/265 Vdc	P01 330 081

Power supply	Reference
20/265 Vac - 11/265 Vdc	P01 330 080

## ASSOCIATED PRODUCTS



**Accessories and option boards**  
Alarm boards  
page 196



**Current transformers & shunts**  
Tertiary, industrial, tariff  
5 to 5,000 A..  
page 120



**Tachometric sensor**  
Please contact us



**Thermocouple / probe**  
See Pyrocontrôle  
Catalog

METERS AND POWER MONITORS  
NETWORK MONITORING FROM LV TO HV  
CURRENT TRANSFORMERS AND SHUNTS  
TRANSDUCERS  
PANEL METERS AND SYNCHROCOUPLER  
AUXILIARY RELAYS  
CIVILIAN AND MILITARY NAVAL APPLICATIONS  
SERVICES AND TRAINING

## DISPLAY

Display range	-9 999...9 999
Display indicators	Red LED, 7 segments
	Height 14 mm
Reading	4 digits
Polarity	Automatic
Overrun	OVE displayed
Decimal position	Programmable by software
Measurement rate	20 measurements / second

## ACCURACY

Vdc. Adc. Aac		±0.05 % of reading
Vac	±20 V	±0.1 % of reading
	±200 V	±0.25 % of reading
	±600 V	±0.35 % of reading
Process signal		±0.1 % of reading
Temperature	Thermocouple J. K. N	±0.1 % of reading
	Thermocouple T	±0.2 % of reading
	Pt 100 / Pt 1000	±0.15 % of reading
Potentiometer		±0.1 % of reading
Resistance		±0.1 % of reading

## MECHANICAL SPECIFICATIONS

Material	Polycarbonate V0 as per UL94
Weight	150 g
Protection rating	IP 65 on front panel
Mounting	On panel using strap

## ENVIRONMENT

Operating temperature	-10 °C to +60 °C
Storage temperature	-25 °C to +85 °C
Relative humidity	< 95 % at +40 °C
Max. altitude	2 000 m

## POWER SUPPLY

Voltage	20/265 Vac - 50/60 Hz – 11/265 Vdc
Consumption	3 VA/3 W

## STANDARD

Low voltage directive 73/23/CEE  
 Insulation - dielectric strength IEC 61010-1

## DIMENSIONS (IN MM)

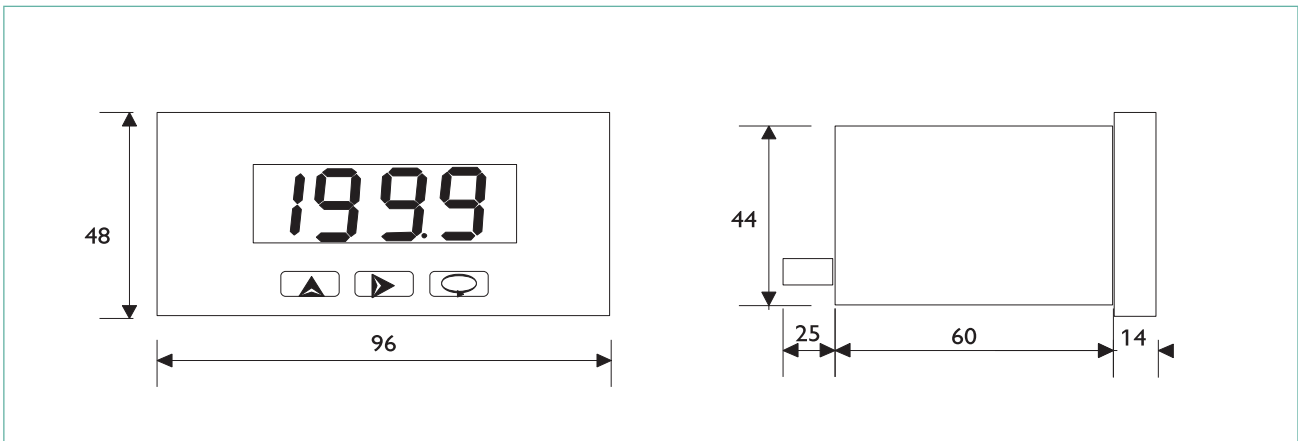

## PANEL DRILLING SPECIFICATIONS (IN MM)

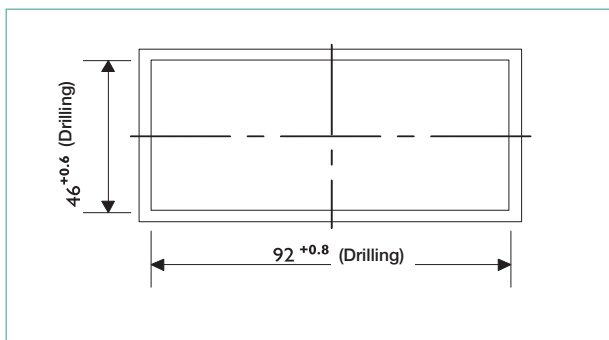

# CA 2150 RANGE

48 x 96 mm programmable digital panel meters for all types of industrial applications.



## USER SECTORS



Industry



Energy generation



Naval applications



3 display colors

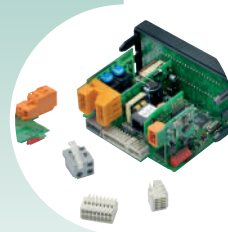

Quick connection using plug-in connectors (spring-cage type)

## DESCRIPTION

The **CA 2150-E** is a 4-in-1 programmable panel meter which can be configured for TRMS Vac or Iac signals and Vdc or Idc signals.

The **CA 2150-M** is a 4-in-1 programmable panel meter which can be configured for process, temperature, load cell or potentiometer signals.

The **CA 2150-D** is a 4-in-1 programmable panel meter which can be configured for the following applications: meter, tachometer, frequency meter and chronometer.

The serial link can be used to transfer the measurements onto a PC.

The configuration software, available free of charge from [www.chauvin-arnoux-energy.com](http://www.chauvin-arnoux-energy.com), can be used to read the measurement directly, and to configure and remotely program one or more connected panel meters. It can also be used to save and recover the configuration of an existing panel meter.



- Multi-function products
- 3 display colors
- 4 alarms as standard
- Instant mounting without tools
- Serial link for remote processing of the measurements
- RS232 or RS485

## OPTION BOARDS\*

Model	Reference
CA 2XXX AL 2-relay board	P01 3193 01
CA 2XXX AL 4-relay board	P01 3193 03
CA 2XXX AL 4 NPN board	P01 3193 04
CA 2XXX COM RS232 board	P01 3193 06
CA 2XXX COM RS485 board	P01 3193 07
CA 2150 0 - 10 V output board	P01 3193 10
CA 2150 4 - 20 mA output board	P01 3193 11

\* Extra boards (addition or replacement)

## CUSTOMIZED PRODUCT

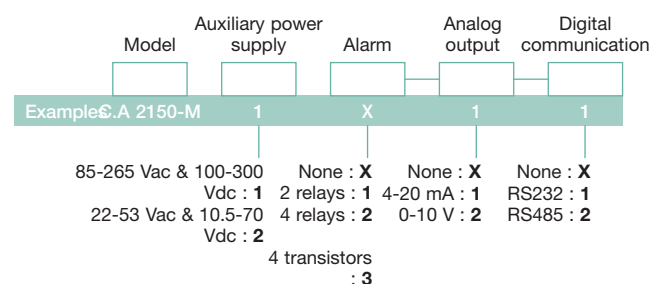

**CA 2150-E****AC input voltage rating (TRMS)**

- 2 V with 75 k $\Omega$
- 20 V, 200 V or 600 V with 850 k $\Omega$

**AC input current rating (TRMS)**

- 200 mA with 0.75  $\Omega$
- 1 A or 5 A with 0.014  $\Omega$
- 50 mV, 60 mV or 100 mV with 1.5 M $\Omega$

**DC input voltage rating**

- 2 V 100 k $\Omega$
- 20 V, 200 V or 600 V with 850 k $\Omega$

**DC input current rating**

- 200 mA with 0.75  $\Omega$
- 1 A or 5 A with 0.014  $\Omega$
- 50 mV, 60 mV or 100 mV with 1.8 M $\Omega$

**CA 2150-M****DC U/I process signals**

- **Voltage:** 0... $\pm$ 10 V with 1 m $\Omega$
- **Current:** 0... $\pm$ 20 mA with 15  $\Omega$

**Temperature**

- **J thermocouple:**  $V_{in} > 120$  mVeff
- **NAMUR sensor:** -50...+800  $^{\circ}$ C / -58...+1,472  $^{\circ}$ F
- **K thermocouple:** -50...+1,200  $^{\circ}$ C / -58...+2,192  $^{\circ}$ F
- **T thermocouple:** -150...+400  $^{\circ}$ C / -302...+752  $^{\circ}$ F
- **Pt 100:** -100...+800  $^{\circ}$ C / -148...+1,472  $^{\circ}$ F

**Load cells**

- 0... $\pm$ 15 mV with 100 m $\Omega$
- 0... $\pm$ 30 mVdc with 100 m $\Omega$
- 0... $\pm$ 150 mV with 100 m $\Omega$

**Potentiometer**

- 200  $\Omega$ ...100 k $\Omega$

**CA 2150-D****Frequencymeter / Tachometer**

- **Fmin :** 0.01 Hz
- **Fmax without relay option:** 19 kHz
- **Fmax with relay option:** 9.9 kHz

**Meter / Chronometer**

- **Fmax without relay option:** 20 kHz
- **Fmax with relay option:** 15 kHz

**Types of inputs**

- **Voltage: 10...300 Vac**
- **Magnetic sensor:**  
 $V_{in} > 60$  mVrms (F < 1 kHz)  
 $V_{in} > 120$  mVrms (F > 1 kHz)

• **NAMUR sensor:**

$R_c = 3.3$  k $\Omega$   
 $I_{on} < 1$  mAdc  
 $I_{off} > 3$  mAdc

• **TTL encoder/24 Vdc:**

"0" < 2.4 Vdc / "1" > 2.6 Vdc  
 $R_c = 3.3$  k $\Omega$

• **Dry contact:**

$V_c = 5$  Vdc /  $R_c = 3.9$  k $\Omega$  /  $F_c = 20$  Hz

**AVAILABLE OPTIONS**

Relay boards	Board with 2 alarms on relays	Board with 4 alarms on relays
<b>Outputs</b>	2 x 1CO relays	4 x 1CO relays
<b>Max. voltage</b>	250 Vac or 12 Vdc	250 Vac or 50 Vdc
<b>Max. current</b>	8 A at 250 Vac or 8 A at 24 Vdc	500 mA at 125 Vac or 1 A at 30 Vdc

Communication board		
<b>Type of link</b>	RS232	RS485
<b>Protocol</b>	ISO1745, CA protocol or ModBus/RTU	
<b>Speed</b>	1200, 2400, 4800, 9600 or 19200 bauds	
<b>Output connector</b>	RJ9-4	RJ11-6 with dual adapter (input + output)

Analog output board		
<b>Output</b>	0... 10 V	4... 20 mA
<b>Accuracy</b>	0.1 % $\pm$ 1 digit	
<b>Temperature coeff.</b>	0.2 mV per K	0.5 $\mu$ A per K
<b>Max. load</b>	> 500 $\Omega$	< 800 $\Omega$

## DISPLAY

	CA 2150-E	CA 2150-M			CA 2150-D		
<b>Measurement rate</b>	50 ms	Process/ load	Pt100	TC	Meter/chrono	Freq./Tacho.	
		50 ms	250 ms	100 ms	100 ms	0.1 to 9.9 s	
<b>Display range</b>	± 1 9999	± 1 9999			Meter	Chrono	Freq./Tacho.
					± 99 999	0 to 999.9	0 to 99 999
<b>Displays</b>	7-segment programmable color LED (red, green, amber), height 14 mm						
<b>Reading</b>	5 digits						
<b>Polarity</b>	Automatic						
<b>Overrun</b>	OvEr / -OvEr						
<b>Decimal position</b>	By programming						

## SENSOR EXCITATION

Model	Input	Excitation
CA 2150-M	Process	24 Vdc @ 60 mA, 10/5 Vdc @ 60 mA
	Load cell	10/5 Vdc @ 60 mA
	Resistance	10 Vdc
	Temperature	< 1 mAdc
CA 2150-D	-	8 Vdc @ 30 mA 20 Vdc (unstabilized) @ 100 mA

## MECHANICAL SPECIFICATIONS

<b>Material</b>	polycarbonate as per UL 94 V-0
<b>Protection rating</b>	IP 65 on front panel
<b>Mounting</b>	On panel using self-locking strap
<b>Weight</b>	CA 2150-D : 160 g
	CA 2150-E : 135 g
	CA 2150-M : 160 g

## ENVIRONMENT

<b>Operating temperature</b>	10 °C to +60 °C
<b>Storage temperature</b>	-25 °C to +80 °C
<b>Relative humidity</b>	< 95 % at +40 °C
<b>Maximum altitude</b>	2 000 m

## POWER SUPPLY

<b>Universal</b>	85 - 265 Vac / 100 - 300 Vdc
<b>Low voltage</b>	10.5 - 70 Vdc / 22 - 53 Vac
<b>Consumption</b>	5 W without option, 8 W max.

## ACCURACY

		Process / Load / Ω	Temperature	Freq. / Tacho.	Meter
<b>Max. error on reading</b>	Vac: ± 0.30 % R Iac: ± 0.30 % R Vdc: ± 0.05 % R Idc: ± 0.10 % R	± 0.1 % R + 1 digit	TC ± 0.4 % R ± 0.6 °C	0.005 % R	0.01 % R
			± 0.4 % R ± 1 °F		
<b>Resolution</b>	2 V rating: 0.1 mV 20 V rating: 1 mV 200 V rating: 10 mV 600 V rating: 10 mV 200 mA rating: 0.01 mA 1 / 5 A rating: 0.1 mA 50 / 60 / 100 mV rating: 0.01 mV	Process: voltage 1 mV / current 1 µA Load cell: 1 µV Temperature: 0.1° / 1° (selectable)	Frequency: : 0.01 Hz Chronometer: : 0.06 s		
<b>Temperature coefficient</b>	100 ppm/°C	100 ppm/°C	50 ppm/°C		

## SPECIAL FUNCTIONS

- Reset to factory configuration
- Change of display color
- Total or partial locking of programming by code
- Display with 2 levels of brightness

## STANDARDS

Insulation – dielectric strength: EN 611010-1 (Category II installation)  
 EMC - Immunity: EN 61000-4-2 EN 61000-4-3, EN 61000-4-4, EN 61000-4-5, EN 61000-4-6 and EN 61000-4-11  
 EMC - emission: EN 55022

## PANEL DRILLING SPECIFICATIONS (IN MM)

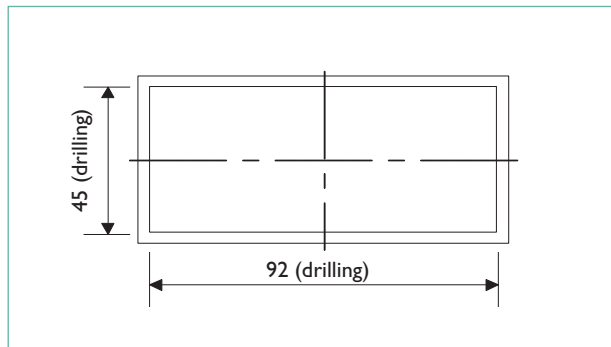

## DIMENSIONS (IN MM)

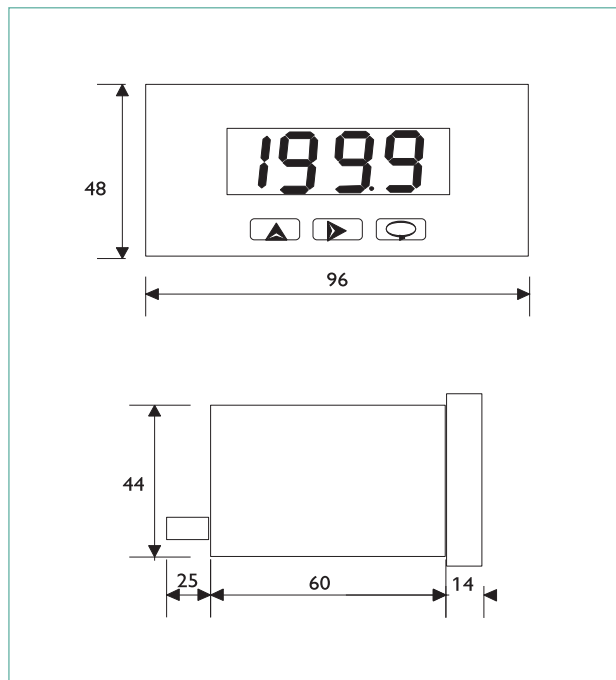

## TO ORDER

Power supply	Reference
20/265 Vac - 11/265 Vdc	P01 330 081

Power supply	CA 2150-E	CA 2150-M	CA 2150-D
85 - 265 Vac / 100 - 300 Vdc	P01308005	P01308001	P01308003
22 - 53 Vac / 10.5 - 70 Vdc	P01308006	P01308002	P01308004

## ASSOCIATED PRODUCTS



**Accessories and option boards**  
 Alarm boards  
 page 196



**Current transformers & shunts**  
 Tertiary, industrial, tariff 5 to 5,000 A.  
 page 120



**Tachometric sensor**  
 Please contact us



**Thermocouple / probe**  
 See Pyrocontrôle Catalog

# SYNCHROCOUPLER RANGE

Synchronization instruments for LV networks.



## USER SECTORS



Industry



Energy generation



Naval applications



Display of deviations between setpoint and measurement



Digital display of 3 measurements: phase, frequency and voltage



User-programmable

## DESCRIPTION

The **SYNCHROCOUPLER** is an automatic synchronization instrument for generator sets. It includes:

- a control relay for assisted manual coupling or automatic coupling with time delay control
- two control relays (fast/slow) for speed adjustment (proportional and integral)
- an external control loop for opening the coupling relay
- four front panel keys for programming, display and messages (password option included)



- **Integration in 96 x 96 format**
- **1 synchronization command**
- **1 control command**
- **3 command modes for synchronization**
- **Control in just a few seconds (PID model)**

## SYNCHROCOUPLER



### Display:

- Phase angle variations by 30 LEDs arranged in a circle
- Voltages, frequencies, variations (in %) on 4 digits
- Frequency variations  $\pm$ , status of coupler relay, conditions obtained in phase, frequency and voltage

## SYNCHROCOUPLER PID



### Display: as for standard synchrocoupler

PID adjustment method (Proportional Integral Derivative) for faster and more accurate synchronization than with conventional synchrocouplers

- **Proportional:** proportional correction of measurement errors
- **Integral:** guarantees reduction of adjustment error to 0
- **Derivative:** brings greater stability to the system, enabling you to anticipate the inertia of generator sets

## TO ORDER

Power supply	Reference
24 VDC	LS9N 421X
48 VDC	LS9N 422X
110 VAC	LS9N 423X
230 VAC	LS9N 424X
400 VAC	LS9N 425X

Power supply	Reference
24 VDC	LS9N 441X
48 VDC	LS9N 442X
110 VAC	LS9N 443X
230 VAC	LS9N 444X
400 VAC	LS9N 445X

## ELECTRICAL SPECIFICATIONS

Measurements	
Rated voltage range	110 to 600 V
Frequency	35 Hz...80 Hz
Permanent overvoltage	800 V
Consumption	< 500 $\mu$ A
Relay output	
With sealed change-over contact	8 A - 250 Vac / 5 A - 30 Vdc
Multi-measurement (accuracy)	
Phase angle deviation	$\pm 0.5^\circ$
Frequency	$\pm 0.01$ Hz
Voltage (RMS)	Class 1 $\pm 2$ digits
Auxiliary power supply	
AC voltage	110, 230, 400, 440, 480 Vac (-10 / +15 %)
Frequency	35 Hz...450 Hz
Consumption	10 VA
DC voltage	9-18 Vdc (12 Vdc), 18-36 Vdc (24 Vdc), 36-72 Vdc (48 Vdc)
Consumption	1.5 W

## ENVIRONMENT

Operating temperature	-10 °C to +65 °C
Storage temperature	-40 °C to +70 °C
Relative humidity	< 90 % to 40 °C
Installation category	3
Pollution level	2

## MECHANICAL SPECIFICATIONS

Casing and flange	Self-extinguishing black ABS
Front panel	Light gray polycarbonate
Protection rating	IP 54 front panel (IP 65 optional)
Weight	505 g
Connection	Holder for 2.5 mm wire
Fitting	Mounting on 8 mm front panel

## STANDARDS

Reference standards	
Safety	IEC 61010-1
Dimensions	DIN 43700
EMC	EN 61326-1
ANSI function	Nos. 25 and 90
Resistance to shock	IEC 60068-2-27
Resistance to vibrations	IEC 60068-2-6
Environment	IEC 60068-1

## ELECTRICAL CONNECTIONS

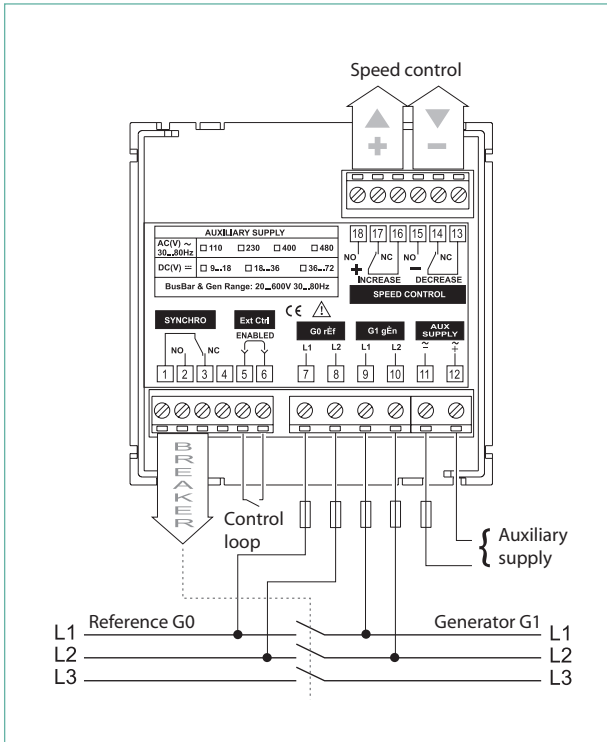

\* EC (control loop): Input 5-6 must be closed to authorize closure of the synchro contact in 1-2-3.

## DIMENSIONS AND DRILLING SPECIFICATIONS (MM)

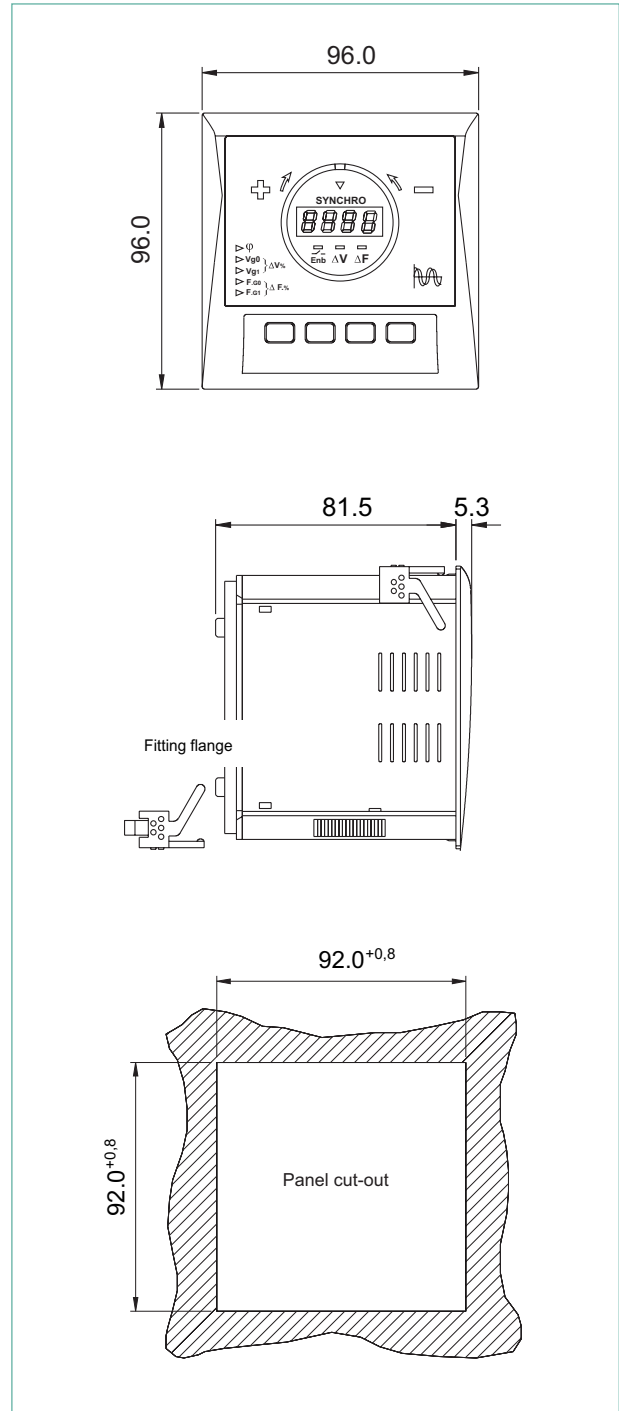

METERS AND POWER MONITORS

NETWORK MONITORING FROM LV TO HV

CURRENT TRANSFORMERS AND SHUNTS

TRANSDUCERS

PANEL METERS AND SYNCHROCOUPLER

AUXILIARY RELAYS

CIVILIAN AND MILITARY NAVAL APPLICATIONS

SERVICES AND TRAINING

# ANALOG PANEL METERS

## CLASSIC RANGE

### FOR STANDARD APPLICATIONS



#### AC ammeter

Analog panel meters with round barrels for day-to-day industrial requirements.

[page 216](#)



#### AC voltmeter

Analog panel meters with round barrels for day-to-day industrial requirements.

[page 218](#)



#### Frequency meter

Analog panel meters with round barrels for day-to-day industrial requirements.

[page 219](#)



#### Wattmeter

Analog panel meters with round barrels for day-to-day industrial requirements.

[page 220](#)



#### Phasemeter

Analog panel meters with round barrels for day-to-day industrial requirements.

[page 220](#)



#### DC ammeter

Analog panel meters with round barrels for day-to-day industrial requirements.

[page 221](#)



#### DC voltmeter

Analog panel meters with round barrels for day-to-day industrial requirements.

[page 222](#)

## USER SECTORS



Industry



Energy transmission & distribution



Nuclear



Naval applications

## NORMEUROPE RANGE

### FOR SEVERE ENVIRONMENTS



#### AC ammeter

Analog panel meters with round barrels for severe operating constraints.

page 226



#### AC voltmeter

Analog panel meters with round barrels for severe operating constraints.

page 228



#### Frequency meter

Analog panel meters with round barrels for severe operating constraints.

page 230



#### Wattmeter / Varmeter

Analog panel meters with round barrels for severe operating constraints.

page 231



#### Phasemeter

Analog panel meters with round barrels for severe operating constraints.

page 232



#### Synchronization units

Analog panel meters with round barrels for severe operating constraints.

page 233



#### DC ammeter

Analog panel meters with round barrels for severe operating constraints.

page 234



#### DC voltmeter

Analog panel meters with round barrels for severe operating constraints.

page 235

## COHO/LK RANGE

### HOURLY METERS



#### COHO

Totalize the operating time of a machine or piece of equipment with the aim of checking or repairing it.

page 236



#### LK

Totalize the operating time of a machine or piece of equipment with the aim of checking or repairing it.

page 237

# CHOOSING AN ANALOG PANEL METER

## CLASSIC

page 214



Front panel drilling			
Round barrel			
Square barrel			
Front panel			
Format	48 x 48	72 x 72	96 x 96
Standard functions			
AC Ammeter	90°	250°	
AC Voltmeter	90°	250°	
Pointer dial frequency meter		90°	
Vibrating reed frequency meter			
Wattmeter / Varmeter		90°	240°
Phasemeter		90°	240°
DC Ammeter	90°	240°	
DC Voltmeter	90°	240°	
Hour meter			
Synchronization equipment			
Double vibrating reed frequency meter			
Differential voltmeter			
<b>Strengths</b>	CLASSIC, the model for day-to-day industrial applications.		

## NORMEUROPE

page 224



48 x 48			72 x 72			96 x 96		
90°			250°					
90°			250°					
			90°			250°		
			1 x 9 reeds					
			90°			250°		
90°			250°					
90°			250°					
			2 x 9 reeds					
			90°					

NORMEUROPE, the industry reference for the generation, transmission and distribution of electrical energy for severe operating constraints.

## COHO / LK

page 236-237



COHO		LK	
		LK	
48 x 48		48 x 48	

COHO, the industry reference for severe operating constraints, and LK for standard applications.

METERS AND POWER MONITORS

NETWORK MONITORING FROM LV TO HV

CURRENT TRANSFORMERS AND SHUNTS

TRANSDUCERS

PANEL METERS AND SYNCHROCOUPLER

AUXILIARY RELAYS

CIVILIAN AND MILITARY NAVAL APPLICATIONS

SERVICES AND TRAINING

# INFO & ADVICE

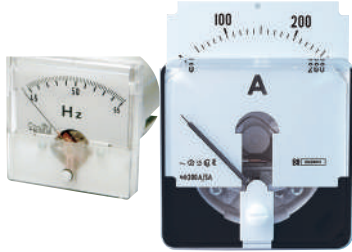

The essential function of the analog panel meter is to display instantaneous and variable values. It shows the pointer's position and movement, both required for monitoring industrial processes.

## SELECTING A PANEL METER

As a panel meter is a low-cost item, it is easily installed at the various control and monitoring points: the switchboard panels of LV distribution networks, motor drive control units or automation device panels.

### Functions

Choose the quantity to be displayed in order to monitor and control a known risk. For an electrical line, for example, the voltage is selected as it is crucial for ensuring user safety.

### Environmental constraints and standards

It is important to take into account mechanical specifications, environmental restrictions, standards in force, consumption and compatibility with sensors, in order to choose the appropriate dial ranges and calibration scales.

### Ergonomics

Choose the instrument size depending on the distance between the operator and the mounting panel. Choose the pointer deflection: a deflection of 240° may be preferred to the usual 90° deflection, to facilitate the reading of extended ranges.

### Options and accessories

Panel meters, though robust by nature, are nevertheless sensitive to degraded environments. It is therefore recommended to choose customized solutions for military applications, for onboard rail applications or for explosive atmospheres.

## MOVING IRON OR MOVING COIL?

The electric current is read directly by a sensor guiding the pointer movement. The most usual types are:

### Moving iron

The moving iron panel meter is composed of a fixed magnet and a mobile magnet, mutually repellant and placed in the field of a coil powered by the current to be measured. For measuring AC signals with a frequency of 50, 60 or 400 Hz. The non-linear scale law is a function of the true root mean square value (TRMS) and the graduation is in TRMS. The measurement is not sensitive to the waveform.

Calibrated for alternating current, it can also measure values in direct current but with a diminished accuracy rating of about 3. The scale can be normal, motor or expanded.

### Moving coil

The moving coil panel meter is composed of a coil traversed by the current to be measured which pivots around a permanently fixed magnet. For measurement of DC signals, the scale law is linear. Due to its low consumption, the moving coil panel meter is the ideal instrument for the measurement of low direct current values. Its scale is linear.

### Moving coil with rectifier

This involves a classic moving coil measuring element equipped with a diode bridge to rectify AC signals. For measuring AC signals from 50 to 10,000 Hz. The linear scale law is a function of the mean rectified value of the signal and the graduation is in RMS. The measurement is sensitive to the waveform.

## USER SECTORS



Industry



Energy transmission & distribution



Nuclear



Naval applications

## DEFINITIONS

**Damping:** Time taken by the needle to stabilize, according to the following requirements:

- **Overrun:** The mechanical overrun must not exceed 20% of the scale length.
- **Response time:** Time necessary for the panel meter to reach and remain within a band centered on the final stable indication when the measured quantity varies suddenly from the value corresponding to unpowered status (zero) on a scale such that the final stable indication is located at a specific point on the scale. The difference between the idle position of the meter and its position after application of a sudden excitation producing a variation of the final indication equal to two third of the scale length must not exceed 1.5 % of the scale length after 4 s.

### Mechanism for adjusting the mechanical zero:

Mechanism which can be used to adjust the instrument so that the mechanical zero coincides with the appropriate scale marking.

**Dial:** Plate mounted on the front panel of the meter and on which the scale and numbering are printed.

**Rating:** This is the largest measurable value for which the maximum deflection is obtained.

**Numbering:** All the numbers indicated for the scale markings.

**Class index:** Also known as the Accuracy Class, this is defined by a value in % and determines the uncertainty of the measurement calculated over the full scale and referred to the measurement. Class 1.5 means that the maximum uncertainty is between + and -1.5% of the full scale, applicable at all points on the scale (e.g. 0-100 A scale: the uncertainty will be  $1.5\% \times 100 = \pm 1.5A$ ). The needle pointing to the 50 A marking really means:  $48.5 A > \text{actual measurement} > 51.5 A$ )

**Cover:** Covers and protects the dial and needle. It may be openable on certain models, with a removable upper element making dial changes quick and easy to perform.

**Division:** Distance between any two consecutive scale markings.

**Scale:** All the markings and numbers which, in combination with the position of the index (needle or vibrating reed) enable you to determine the value of the quantity measured.

**Repeatability:** Property of always showing the same deflection for a given value of the quantity measured.

**Graduation:** The set formed by the scale+numbering; it complies with the IEC 60051-1 standard.

**Markings (on a scale):** Markings on the dial whose purpose is to divide the scale into convenient intervals so that the position of the index (needle or vibrating reed) can be determined.

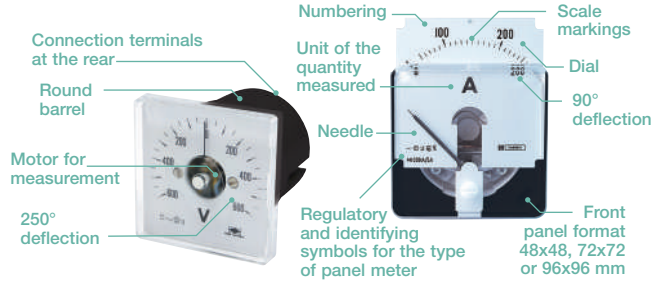

### Enclosure ingress protection (IP rating):

Represents a level of protection provided by the instrument's enclosure. The protection rating is stated by means of 2 separate digits.

### INGRESS PROTECTION: TWO DIGITS

Rating	1st digit (tens) Protection against solids	2nd digit (units) Protection against water ingress
0	No protection	No protection
1	Protected against solid bodies larger than 50 mm across	Protected against water droplets falling vertically
2	Protected against solid bodies larger than 12.5 mm across	Protected against water droplets falling at up to 15° from the vertical
3	Protected against solid bodies larger than 2.5 mm across	Protected against water spray at up to 60° from the vertical
4	Protected against solid bodies larger than 1 mm across	Protected against water spray from any direction
5	Protected against dust and other microscopic residue	Protected against hose water spray from all directions (nozzle 6.3 mm, distance 2.5 to 3 m, flow rate 12.5 l / mm ± 5%)

### MEANINGS OF THE REGULATORY MARKINGS ON DIAL:

	Dielectric voltage test (4 kV)		Moving-coil instrument with built-in rectifier
1.5	Accuracy class 1.5		Vibrating-reed frequency meter
	Vertical position of dial		For connection to 100/5A CT
	Horizontal position of dial		For connection to 380/100V VT
	Inclined position of dial in relation to the horizontal		Usable with direct current
	Standard – IEC 60051-1		Moving-coil instrument
	Usable with direct and alternating current		External shunt with measurement lead, R = 0.02 Ω
	Usable with alternating current		Additional resistance
	Moving-iron device		Caution

METERS AND POWER MONITORS

NETWORK MONITORING FROM LV TO HV

CURRENT TRANSFORMERS AND SHUNTS

TRANSDUCERS

PANEL METERS AND SYNCHROCOUPLER

AUXILIARY RELAYS

CIVILIAN AND MILITARY NAVAL APPLICATIONS

SERVICES AND TRAINING

# CLASSIC RANGE

Analog panel meters with round barrels for day-to-day industrial requirements.

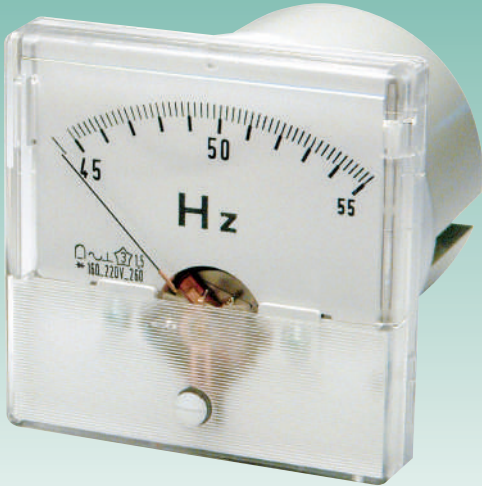

## USER SECTORS



Industry



Slimline and easy to install



Accurate



Rugged

## GENERAL SPECIFICATIONS

**Reference standard:** IEC 60051-1

**Accuracy:** accuracy class 1.5  
( $\pm 1.5$  % error at full scale)

**Front-panel protection:** IP52 reference IEC 60529

**Isolation test:** reference IEC 61010-1 Category III

**Max. operating voltage:** 650 Vac

**Mechanical shocks:** reference standard IEC 60068-2-27

**Vibration withstand:** reference IEC 60068-2-6

**Environment:** reference IEC 68-1

**Reference temperature:** 23 °C  $\pm$  2 °C

**Operating temperature:** -25 °C to +50 °C

**Storage temperature:** -25 °C to +70 °C

**Relative humidity:** < 90 % at 40 °C

**Mounting:** Front mounting on panel

**Panel thickness:** 8 mm max.

### Materials:

Barrel: ABS

Front panel: polymethyl methacrylate

Additional casing: ABS

Dial: ABS/PC, black markings on white background.

Black bar needle



- Attractive acquisition and installation costs
- Multiple customization possibilities for switchboard and machine manufacturers

**Operating position:** Calibration for vertical position ( $\pm 10^\circ$ )

### Overloads :

Voltmeter and frequencymeter

- 1.2 Un permanent
  - 2 Un for 5 s
- Ammeter
- 1.3 In permanent
  - 10 In for 5 s

**Extreme values:** recommendation, IEC 60 051-1 standard 1 - 1.2 - 1.5 - 2 - 2.5 - 3 - 4 - 5 - 6 - 7.5 - 8 - 9 and their decimal multiples and sub-multiples

## DIMENSIONS AND DRILLING OF THE PANEL

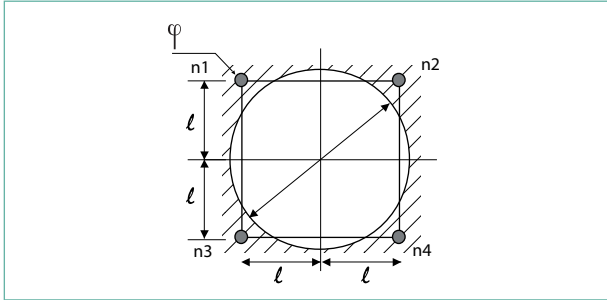
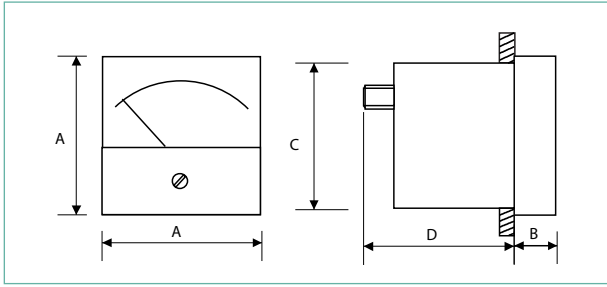

A x A Format	48 x 48	72 x 72	96 x 96
B (mm)	12	13	14
C (mm)	44	65	65
D 90° (mm)	48	35	35
D 240° (mm)		70	70
Ø (mm)	45	67	67
l (mm)	20	28.5	40
ni IP52 (mm)	n1	n1-n4	n1-n4
ni IP55 (mm)	n1	n1-n2-n3-n4	n1-n2-n3-n4
e (mm)	Ø 3.5	Ø 4	Ø 4
Standard mounting	clamp	2 studs M3	2 studs M3
Weight (kg)	90°	0.180	0.180
	240°	0.250	0.250
Connection	M5	M5	M5

## MECHANICAL FORMATS

Format	Deflection	90°			240°	
		48 x 48	72 x 72	96 x 96	72 x 72	96 x 96
<b>Non-standard mounting and front-panel tightness</b>						
IP55 (4-stud mounting and zero reset seal)		■	■	■	■	■
Mounting by automatic clip		■				
Mounting strap		■ as standard	■	■	■	■
<b>Non-standard front-panel cover</b>						
Locator index		■	■	■		
<b>Non-standard dial format</b>						
Creation of dial markings (after feasibility study)		■	■	■	■	■
Color marking		■	■	■	■	■
Color area		■	■	■	■	■
Black background with white markings		■	■	■	■	■
Markings not in standard documentation		■	■	■	■	■
Double scale			■	■	■	■

## ACCESSORIES

Format	Deflection	90°			240°	
		48 x 48	72 x 72	96 x 96	72 x 72	96 x 96
Front-panel sealed gasket		1890 0011	1890 0009	1890 0010	1890 0009	1890 0010
Cylindrical ring fastener			N003 34A00		N003 34A00	
Standard dial		■	■	■	■	■
Customized dial (on request)		■	■	■	■	■
Flask of antistatic liquid		9030 00676	9030 00676	9030 00676	9030 00676	9030 00676
Insulation cap for terminals		0026 2803	0026 2803	0026 2803	0026 2803	0026 2803
Faston terminal connections		■	■	■	■	■

# AC AMMETER

Analog panel meters with round barrels for day-to-day industrial requirements.

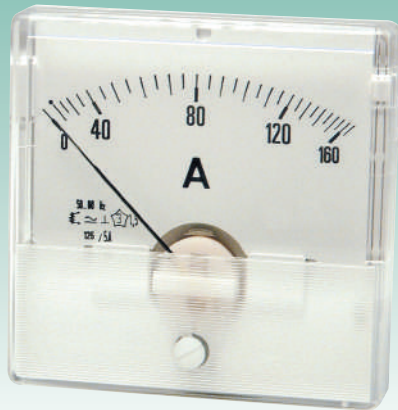

## 90° DEFLECTION

**Standard-scale model**

**Accuracy class:** 1.5

**Measuring component:** moving iron 50 to 60 Hz, rectified moving coil 50 to 10,000 Hz

Pseudo-linear scale (moving iron)

Interchangeable dial

**Consumption:** 1 VA

**Motor-scale models**

**Accuracy class:** 1.5

**Measuring component:** moving iron 50-60 Hz

Pseudo-linear scale

Calibrated 0-In up to 2/3 of deflection, with overload zone beyond

Interchangeable dial

**Consumption:** 1 VA

## 240° DEFLECTION

**In standard-scale model**

**Accuracy class:** 1.5

**Measuring component:** rectified moving coil 50 to 10,000 Hz

Linear scale

**Consumption:** 0.5 VA

**Motor-scale models**

**Accuracy class:** 1.5

**Measuring component:** rectified moving coil

50 to 10,000 Hz

Linear scale

Calibrated 0-In up to 2/3 of deflection, with overload zone beyond

zone beyond

**Consumption:** 0.5 VA

## FEASIBILITY LIMITS

Deflection		90°			240°	
Format		48 x 48	72 x 72	96 x 96	72 x 72	96 x 96
<b>Direct connection</b>						
Standard scale	moving iron	100 mA to 30 A	100 mA to 30 A	100 mA to 30 A		
	moving coil		100 mA to 30 A	100 mA to 30 A	100 mA to 30 A	100 mA to 30 A
Motor scale	moving iron 6 In max	1-30 A	1-30 A	1-30 A		
	moving coil 3 In		1-30 A	1-30 A	1-30 A	1-30 A
<b>Connection on CT</b>						
Standard scale	moving iron	1-6.5 A	1-6.5 A	1-6.5 A		
	moving coil		1-6.5 A	1-6.5 A	1-6.5 A	1-6.5 A
Motor scale	moving iron 6 In max	1-5 A	1-5 A	1-5 A		
	moving coil 3 In		1-5 A	1-5 A	1-5 A	1-5 A

## DIRECT CONNECTION

Deflection		moving iron 90°			240°	
Format		48 x 48	72 x 72	96 x 96	72 x 72	96 x 96
<b>Rating</b>	<b>Scale In</b>					
5 A	0-5 A	1048 1207	1082 1207	1083 1207	2074 1207	2075 1207
10 A	0-10 A	1048 1212	1082 1212	1083 1212	2074 1212	2075 1212
20 A	0-20 A	1048 1215	1082 1215	1083 1215	2074 1215	2075 1215
30 A	0-30 A	1048 1217	1082 1217	1083 1217	2074 1217	2075 1217
	<b>Scale 3 In</b>					
5 A	0-5/15 A	1048 9507	1082 9507	1083 9507	2074 9507	2075 9507
10 A	0-10/30 A	1048 9512	1082 9512	1083 9512	2074 9512	2075 9512
20 A	0-20/60 A	1048 9515	1082 9515	1083 9515	2074 9515	2075 9515
	<b>Scale 5 In</b>					
5 A	0-5/25 A	1048 9607	1082 9607	1083 9607		

## CUSTOMIZED PRODUCT

	Instrument	Deflection	Measuring component	Format	Scale	CT ratio rating	Frequency
Examples	Complete panel meter	90°	coil	72 x 72	0-12/36A	direct 12A	60 Hz
	Panel meter only	90°	iron	48 x 48	In	TC/1A	50 Hz
	Dial only	90°	iron	48 x 48	0-225/675A	TC225/1A	50 Hz

# CONNECTION TO 5 A CT

Deflection		moving iron 90°			moving iron 90°			240°	
		Separate panel meter and dial			Complete panel meter			Complete panel meter	
Format		48 x 48	72 x 72	96 x 96	48 x 48	72 x 72	96 x 96	72 x 72	96 x 96
Scale 1.3 In		Panel meter only							
CT ratio		1048 1299	1082 1299	1083 1299					
Scale 1.3 In		Dial only							
5/5 A	0-6.5 A	1961 0507	1962 0507	1963 0507	1048 2407	1082 2407	1083 2407	2074 9107	2075 9107
10/5 A	0-13 A	1961 0512	1962 0512	1963 0512	1048 2412	1082 2412	1083 2412	2074 9112	2075 9112
15/5 A	0-19.5 A	1961 0514	1962 0514	1963 0514	1048 2414	1082 2414	1083 2414	2074 9114	2075 9114
20/5 A	0-26 A	1961 0515	1962 0515	1963 0515	1048 2415	1082 2415	1083 2415	2074 9115	2075 9115
25/5 A	0-32.5 A	1961 0516	1962 0516	1963 0516	1048 2416	1082 2416	1083 2416	2074 9116	2075 9116
30/5 A	0-39 A	1961 0517	1962 0517	1963 0517	1048 2417	1082 2417	1083 2417	2074 9117	2075 9117
40/5 A	0-52 A	1961 0518	1962 0518	1963 0518	1048 2418	1082 2418	1083 2418	2074 9118	2075 9118
50/5 A	0-65 A	1961 0519	1962 0519	1963 0519	1048 2419	1082 2419	1083 2419	2074 9119	2075 9119
60/5 A	0-78 A	1961 0521	1962 0521	1963 0521	1048 2421	1082 2421	1083 2421	2074 9121	2075 9121
75/5 A	0-97.5 A	1961 0523	1962 0523	1963 0523	1048 2423	1082 2423	1083 2423	2074 9123	2075 9123
100/5 A	0-130 A	1961 0525	1962 0525	1963 0525	1048 2425	1082 2425	1083 2425	2074 9125	2075 9125
125/5 A	0-162.5 A	1961 0526	1962 0526	1963 0526	1048 2426	1082 2426	1083 2426	2074 9126	2075 9126
150/5 A	0-195 A	1961 0528	1962 0528	1963 0528	1048 2428	1082 2428	1083 2428	2074 9128	2075 9128
200/5 A	0-260 A	1961 0530	1962 0530	1963 0530	1048 2430	1082 2430	1083 2430	2074 9130	2075 9130
250/5 A	0-325 A	1961 0531	1962 0531	1963 0531	1048 2431	1082 2431	1083 2431	2074 9131	2075 9131
300/5 A	0-390 A	1961 0533	1962 0533	1963 0533	1048 2433	1082 2433	1083 2433	2074 9133	2075 9133
400/5 A	0-520 A	1961 0535	1962 0535	1963 0535	1048 2435	1082 2435	1083 2435	2074 9135	2075 9135
500/5 A	0-650 A	1961 0536	1962 0536	1963 0536	1048 2436	1082 2436	1083 2436	2074 9136	2075 9136
600/5 A	0-780 A	1961 0538	1962 0538	1963 0538	1048 2438	1082 2438	1083 2438	2074 9138	2075 9138
750/5 A	0-975 A	1961 0540	1962 0540	1963 0540	1048 2440	1082 2440	1083 2440	2074 9140	2075 9140
800/5 A	0-1.04 kA	1961 0541	1962 0541	1963 0541	1048 2441	1082 2441	1083 2441	2074 9141	2075 9141
1000/5 A	0-1.3 kA	1961 0542	1962 0542	1963 0542	1048 2442	1082 2442	1083 2442	2074 9142	2075 9142
1200/5 A	0-1.56 kA	1961 0551	1962 0551	1963 0551	1048 2451	1082 2451	1083 2451	2074 9151	2075 9151
1500/5 A	0-1.95 kA	1961 0544	1962 0544	1963 0544	1048 2444	1082 2444	1083 2444	2074 9144	2075 9144
2000/5 A	0-2.6 kA	1961 0545	1962 0545	1963 0545	1048 2445	1082 2445	1083 2445	2074 9145	2075 9145
2500/5 A	0-3.25 kA	1961 0546	1962 0546	1963 0546	1048 2446	1082 2446	1083 2446	2074 9146	2075 9146
3000/5 A	0-3.9 kA	1961 0547	1962 0547	1963 0547	1048 2447	1082 2447	1083 2447	2074 9147	2075 9147
4000/5 A	0-5.2 kA	1961 0549	1962 0549	1963 0549	1048 2449	1082 2449	1083 2449	2074 9149	2075 9149
5000/5 A	0-6.5 kA	1961 0550	1962 0550	1963 0550	1048 2450	1082 2450	1083 2450	2074 9150	2075 9150
Scale 3 In		Panel meter only							
CT ratio		1048 9597	1082 9597	1083 9597					
Scale 3 In		Dial only							
5/5 A	0-5/15 A	1961 0607	1962 0607	1963 0607	1048 2607	1082 2607	1083 2607	2074 9207	2075 9207
10/5 A	0-10/30 A	1961 0612	1962 0612	1963 0612	1048 2612	1082 2612	1083 2612	2074 9212	2075 9212
15/5 A	0-15/45 A	1961 0614	1962 0614	1963 0614	1048 2614	1082 2614	1083 2614	2074 9214	2075 9214
20/5 A	0-20/60 A	1961 0615	1962 0615	1963 0615	1048 2615	1082 2615	1083 2615	2074 9215	2075 9215
25/5 A	0-25/75 A	1961 0616	1962 0616	1963 0616	1048 2616	1082 2616	1083 2616	2074 9216	2075 9216
30/5 A	0-30/90 A	1961 0617	1962 0617	1963 0617	1048 2617	1082 2617	1083 2617	2074 9217	2075 9217
40/5 A	0-40/120 A	1961 0618	1962 0618	1963 0618	1048 2618	1082 2618	1083 2618	2074 9218	2075 9218
50/5 A	0-50/150 A	1961 0619	1962 0619	1963 0619	1048 2619	1082 2619	1083 2619	2074 9219	2075 9219
60/5 A	0-60/180 A	1961 0621	1962 0621	1963 0621	1048 2621	1082 2621	1083 2621	2074 9221	2075 9221
75/5 A	0-75/225 A	1961 0623	1962 0623	1963 0623	1048 2623	1082 2623	1083 2623	2074 9223	2075 9223
100/5 A	0-100/300 A	1961 0625	1962 0625	1963 0625	1048 2625	1082 2625	1083 2625	2074 9225	2075 9225
125/5 A	0-125/375 A	1961 0626	1962 0626	1963 0626	1048 2626	1082 2626	1083 2626	2074 9226	2075 9226
150/5 A	0-150/450 A	1961 0628	1962 0628	1963 0628	1048 2628	1082 2628	1083 2628	2074 9228	2075 9228
200/5 A	0-200/600 A	1961 0630	1962 0630	1963 0630	1048 2630	1082 2630	1083 2630	2074 9230	2075 9230
250/5 A	0-250/750 A	1961 0631	1962 0631	1963 0631	1048 2631	1082 2631	1083 2631	2074 9231	2075 9231
300/5 A	0-300/900 A	1961 0633	1962 0633	1963 0633	1048 2633	1082 2633	1083 2633	2074 9233	2075 9233
400/5 A	0-400/1200 A	1961 0635	1962 0635	1963 0635	1048 2635	1082 2635	1083 2635	2074 9235	2075 9235
500/5 A	0-500/1500 A	1961 0636	1962 0636	1963 0636	1048 2636	1082 2636	1083 2636	2074 9236	2075 9236
600/5 A	0-600/1800 A	1961 0638	1962 0638	1963 0638	1048 2638	1082 2638	1083 2638	2074 9238	2075 9238
750/5 A	0-750/2250 A	1961 0640	1962 0640	1963 0640	1048 2640	1082 2640	1083 2640	2074 9240	2075 9240
800/5 A	0-800/2400 A	1961 0641	1962 0641	1963 0641	1048 2641	1082 2641	1083 2641	2074 9241	2075 9241
1000/5 A	0-1/3 kA	1961 0642	1962 0642	1963 0642	1048 2642	1082 2642	1083 2642	2074 9242	2075 9242
1200/5 A	0-1.2/3.6 kA	1961 0651	1962 0651	1963 0651	1048 2651	1082 2651	1083 2651	2074 9251	2075 9251
1500/5 A	0-1.5/4.5 kA	1961 0644	1962 0644	1963 0644	1048 2644	1082 2644	1083 2644	2074 9244	2075 9244
2000/5 A	0-2/6 kA	1961 0645	1962 0645	1963 0645	1048 2645	1082 2645	1083 2645	2074 9245	2075 9245
2500/5 A	0-2.5/7.5 kA	1961 0646	1962 0646	1963 0646	1048 2646	1082 2646	1083 2646	2074 9246	2075 9246
3000/5 A	0-3/9 kA	1961 0647	1962 0647	1963 0647	1048 2647	1082 2647	1083 2647	2074 9247	2075 9247
4000/5 A	0-4/12 kA	1961 0649	1962 0649	1963 0649	1048 2649	1082 2649	1083 2649	2074 9249	2075 9249
5000/5 A	0-5/15 kA	1961 0650	1962 0650	1963 0650	1048 2650	1082 2650	1083 2650	2074 9250	2075 9250
To be specified	Scale 1 In				1048 1297C	1082 1297C	1083 1297C	2074 9193C	2075 9193C
To be specified	Scale 1.3 In				1048 1299C	1082 1299C	1083 1299C	2074 9293C	2075 9293C
To be specified	Scale 3 In				1048 9597C	1082 9597C	1083 9597C		
To be specified	Scale 5 In				1048 9697C	1082 9697C	1083 9697C		

## ASSOCIATED PRODUCTS



### Accessories

Seal, ring fastener, dial, sleeve, etc.  
page 215



### Current transformers

Cable primary, busbar primary, closed core or split core, etc.  
page 108

# AC VOLTMETER

Analog panel meters with round barrels for severe operating constraints.



## 90° DEFLECTION

**Standard-scale model**

**Accuracy class:** 1.5

**Measuring component:**

moving iron 50/60 Hz, and

rectified moving coil 50-10,000 Hz

Pseudo-linear scale (iron)

Interchangeable dial

**Consumption:** 3.5 to 6 VA depending on rating

## 240° DEFLECTION

**Standard-scale model**

**Accuracy class:** 1.5

**Measuring component:**

rectified moving coil 50 - 10,000 Hz

Linear scale

**Consumption:** 1 mA

## ASSOCIATED PRODUCTS



### Accessories

Seal, ring fastener, dial, sleeve, etc.  
page 215

## FEASIBILITY LIMITS

Format	Deflection		90°		240°	
	48 x 48	72 x 72	96 x 96	72 x 72	96 x 96	
<b>Direct connection</b>						
moving iron	6 to 600 V	6 to 600 V	6 to 600 V	6 to 600 V	6 to 600 V	
moving coil	3 to 600 V	3 to 600 V	3 to 600 V	6 to 600 V	6 to 600 V	
<b>Connection to VT</b>						
moving iron		from 100/√3 V				
moving coil		from 100/√3 V		from 100/√3 V		

## DIRECT CONNECTION

Format	Rating	Scale Vr	Deflection		moving iron 90°		240°	
			48 x 48	72 x 72	96 x 96	72 x 72	96 x 96	
15 V	0-15 V		1048 0214	1082 0214	1083 0214	2074 0214	2075 0214	
30 V	0-30 V		1048 0217	1082 0217	1083 0217	2074 0217	2075 0217	
60 V	0-60 V		1048 0221	1082 0221	1083 0221	2074 0221	2075 0221	
150 V	0-150 V		1048 0228	1082 0228	1083 0228	2074 0228	2075 0228	
250 V	0-250 V		1048 0231	1082 0231	1083 0231	2074 0231	2075 0231	
300 V	0-300 V		1048 0233	1082 0233	1083 0233	2074 0233	2075 0233	
500 V	0-500 V		1048 0236	1082 0236	1083 0236	2074 0236	2075 0236	

## CONNECTION TO VT

Format	VT ratio	Scale	Deflection		moving iron 90°		240°	
			48 x 48	72 x 72	96 x 96	72 x 72	96 x 96	
Always specify VT ratio when ordering								
TT/100 √3V	1,2 Vn		-	-	-	2084 0621C	2085 0621C	
TT/100 V	1,2 Vn		1048 0625C	1082 0625C	1083 0625C	2084 0625C	2085 0625C	

## CUSTOMIZED PRODUCT

	Connection	Deflection	Measuring component	Format	Scale	VT rating or ratio	Frequency
Examples	direct	240°	moving coil	96 x 96	Vn	110 V	50 Hz

# FREQUENCY METER

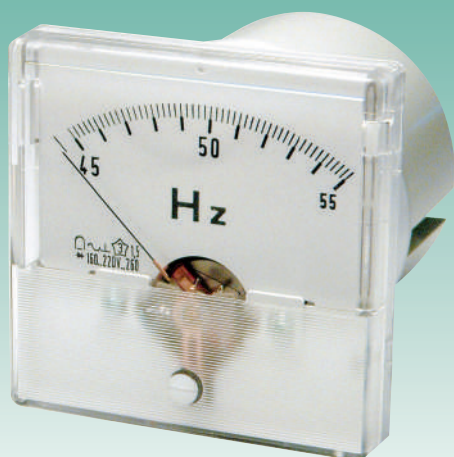

## Pointer frequencymeter

### 90° DEFLECTION

**Accuracy class:** 0.5 Fn

**Measuring component :** moving coil  
+ frequency converter

**Operating range:** 0.8 Un to 1.15 Un

**Consumption :** 1 VA with 100 V, 1.5 VA with 230 V, 2 VA with 400 V

CH version with built-in hour meter from 0 to 99999.9 hours in 96 x 96 format

## FEASIBILITY LIMITS

Voltage: 57.7 V to 440 V

Frequency: 50 to 400 Hz

Deflection		90°		
Format		48 x 48	96 x 96	96 x 96 CH
Rated voltage	Measurement range			Hour meter
100 V	45-55 Hz	3582 3511	3583 3511	3583 3371
	55-65 Hz	3582 3521	3583 3521	3583 3381
230 V	45-55 Hz	3582 3512	3583 3512	3583 3372
	55-65 Hz	3582 3522	3583 3522	3583 3382
400 V	45-55 Hz	3582 3513	3583 3513	3583 3373
	55-65 Hz	3582 3523	3583 3523	3583 3383

## CUSTOMIZED PRODUCT

	Format	Voltage	Measurement range	Hour meter
Example	72 x 72	150 V	350-450 HZ	<input checked="" type="checkbox"/>

## ASSOCIATED PRODUCTS



### Accessories

Seal, ring fastener, dial, sleeve, etc.  
page 215



### TRIAD 2

Digital transducers  
1 to 4 analog outputs.  
Class 0.1  
page 156

# WATTMETER VARMETER



- Panel meter
- 90° - 240° DEFLECTION
- Accuracy class: 1.5
- Measuring component moving coil
- Linear scale

# PHASEMETER



- Panel meter
- See transducers page 167

## PANEL METER

		Deflection		90°		240°	
Format		72 x 72	96 x 96	72 x 72	96 x 96		
Rating	Scale Vr						
0 - 20 mA	0 left	2086 1415C	2087 1415C	2084 1415C	2085 1415C		
4 - 20 mA	0 left	2086 1490C	2087 1490C	2084 1490C	2085 1490C		

## TRANSDUCERS

See transducers page 204

## CUSTOMIZED PRODUCT

Wattmeter / Varmeter	Panel meter	Transducer model	CT ratio	Direct/VT	Voltage or VT ratio	Start/end of scale	Auxiliary power supply
Examples	2085 1490C	TRIAD 2	500/5 A	TT	20 kV / 110 V	-20...+20 MW	110 Vac

Phasemeter	Panel meter	Transducer model	Current	Highest voltage	Start/end of scale	Auxiliary power supply
Examples	2086 1415C	TRIAD 2	1 A	440 V	0.5 cap/1/0.5 ind	230 Vac

## ASSOCIATED PRODUCTS

**Accessories**  
Seal, ring fastener,  
dial, sleeve, etc.  
page 215



**TRIAD 2**  
Digital  
transducers  
1 to 4 analog  
outputs. Class  
0.1.  
page 156



**Current  
transformers**  
Cable primary,  
busbar primary,  
closed core or split  
core, etc.  
page 106



**Les T82N**  
Convertisseurs  
à technologie  
analogiques.  
page 172

# DC AMMETER

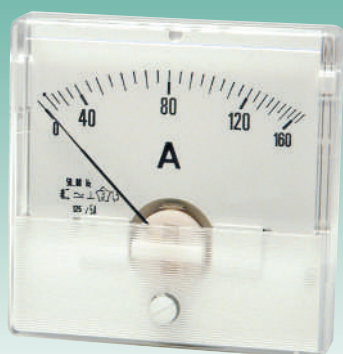

## 90° DEFLECTION

Accuracy class: 1.5

Measuring component: moving coil

Linear scale

Voltage drop:

20 mV for rating  $\geq 1.25$  mA

variable for rating  $< 1.25$  mA

## 240° DEFLECTION

Accuracy class: 1.5

Measuring component moving coil

Linear scale

Voltage drop:

40 mV for rating  $\geq 6$  mA

variable for rating  $< 6$  mA

## FEASIBILITY LIMITS

		Deflection 90°			240°	
Format	Zero position	48 x 48	72 x 72	96 x 96	72 x 72	96 x 96
Direct	Left or central	50 $\mu$ A to 30 A			250 $\mu$ A to 30 A	
Process signal	Left or offset	0-1 mA to 0-20 mA and 4-20 mA			0-1 mA to 0-20 mA and 4-20 mA	
On shunt	Left or central	50 mV to 300 mV			50 mV to 300 mV	

## DIRECT CONNECTION

		Deflection 90° (Iron. 50Hz)			240°	
Format	Scale	48 x 48	72 x 72	96 x 96	72 x 72	96 x 96
5 A	0-5 A	2048 1207	2086 1207	2087 1207	2084 1207	2085 1207
10 A	0-10 A	2048 1212	2086 1212	2087 1212	2084 1212	2085 1212
15 A	0-15 A	2048 1214	2086 1214	2087 1214	2084 1214	2085 1214
25 A	0-25 A	2048 1216	2086 1216	2087 1216	2084 1216	2085 1216
Always specify start and end of scale when ordering						
0-20 mA	Process	2048 1415C	2086 1415C	2087 1415C	2084 1415C	2085 1415C
4-20 mA	Process	2048 1190C	2086 1490C	2087 1490C	2084 1490C	2085 1490C

## CONNECTION TO 100 mV SHUNT

		Deflection 90°		
Format	Scale	48 x 48	72 x 72	96 x 96
Panel meter only		2048 5293	2086 5293	2087 5293
Shunt	Dial only			
5 A	0-5 A	2961 0307	2962 0307	2963 0307
10 A	0-10 A	2961 0312	2962 0312	2963 0312
15 A	0-15 A	2961 0314	2962 0314	2963 0314
20 A	0-20 A	2961 0315	2962 0315	2963 0315
25 A	0-25 A	2961 0316	2962 0316	2963 0316
30 A	0-30 A	2961 0317	2962 0317	2963 0317
40 A	0-40 A	2961 0318	2962 0318	2963 0318
50 A	0-50 A	2961 0319	2962 0319	2963 0319
60 A	0-60 A	2961 0321	2962 0321	2963 0321
75 A	0-75 A	2961 0323	2962 0323	2963 0323

		Deflection 90°		
Format	Scale	48 x 48	72 x 72	96 x 96
Panel meter only		2048 5293	2086 5293	2087 5293
Shunt	Dial only			
100 A	0-100 A	2961 0325	2962 0325	2963 0325
125 A	0-125 A	2961 0326	2962 0326	2963 0326
150 A	0-150 A	2961 0328	2962 0328	2963 0328
200 A	0-200 A	2961 0330	2962 0330	2963 0330
250 A	0-250 A	2961 0331	2962 0331	2963 0331
300 A	0-300 A	2961 0333	2962 0333	2963 0333
400 A	0-400 A	2961 0335	2962 0335	2963 0335
500 A	0-500 A	2961 0336	2962 0336	2963 0336
600 A	0-600 A	2961 0338	2962 0338	2963 0338
1000 A	0-1000 A	2961 0342	2962 0342	2963 0342

		Deflection 90°			240°	
Format	Scale Vr	48 x 48	72 x 72	96 x 96	72 x 72	96 x 96
Always specify the rated current of the shunt						
50 mV	Left	2048 5093C	2086 5093C	2087 5093C	2084 0319C	2085 0319C
60 mV	Left	2048 5193C	2086 5193C	2087 5193C	2084 0321C	2085 0321C
100 mV	Left	2048 5293C	2086 5293C	2087 5293C	2084 0325C	2085 0325C
50 mV	Central	3048 5093C	3086 5093C	3087 5093C	3084 0319C	3085 0319C
60 mV	Central	3048 5193C	3086 5193C	3087 5193C	3084 0321C	3085 0321C
100 mV	Central	3048 5293C	3086 5293C	3087 5293C	3084 0325C	3085 0325C

## CUSTOMIZED PRODUCT

	Connection	Deflection	Format	Zero position	Rating	Start/end of scale
Example	Shunt 2000 A	240°	96 x 96	central	60 mV	-2000 +2000A

# DC VOLTMETER



## 90° DEFLECTION

**Accuracy class:** 1.5

**Measuring component:** moving coil  
Linear scale

**Consumption:** 1 mA

## 240° DEFLECTION

**Accuracy class:** 1.5

**Measuring component:** moving coil  
Linear scale

**Consumption:** 5 mA for  $U_n < 5\text{ V}$   
0.5 mA for  $U_n \geq 5\text{ V}$

## FEASIBILITY LIMITS

Deflection		90°			240°	
<b>Format</b>		48 x 48	72 x 72	96 x 96	72 x 72	96 x 96
<b>Connection</b>	<b>Zero position</b>					
<b>Direct</b>	<b>Left or central</b>	50 mV to 600 V			50 mV to 600 V	
<b>Process signal</b>	<b>Left and offset</b>	0-1 V to 0-10 V			0-1 V to 0-10 V	

## DIRECT CONNECTION

Deflection		iron. 90°			240°	
<b>Format</b>		48 x 48	72 x 72	96 x 96	72 x 72	96 x 96
<b>Rating</b>	<b>Linear scale</b>					
<b>15 V</b>	<b>0-15 V</b>	2048 0214	2086 0214	2087 0214	2084 0214	2085 0214
<b>30 V</b>	<b>0-30 V</b>	2048 0217	2086 0217	2087 0217	2084 0217	2085 0217
<b>60 V</b>	<b>0-60 V</b>	2048 0221	2086 0221	2087 0221	2084 0221	2085 0221
<b>75 V</b>	<b>0-75 V</b>	2048 0223	2086 0223	2087 0223	2084 0223	2085 0223
<b>150 V</b>	<b>0-150 V</b>	2048 0228	2086 0228	2087 0228	2084 0228	2085 0228
<b>300 V</b>	<b>0-300 V</b>	2048 0233	2086 0233	2087 0233	2084 0233	2085 0233
<b>Rating</b>	<b>Expanded scale</b>					
<b>30 V</b>	<b>20-30 V</b>		2086 3290	2087 3220		
<b>60 V</b>	<b>40-60 V</b>		2086 3291	2087 3221		

## READING OF PROCESS SIGNAL

Deflection		90°			240°	
<b>Format</b>		48 x 48	72 x 72	96 x 96	72 x 72	96 x 96
<b>Rating</b>	<b>Scale</b>	Always specify the start and end of scale when ordering				
<b>0-1 V</b>	<b>Process</b>	2048 0401C	2086 0401C	2087 0401C	2084 0401C	2085 0401C
<b>0-10 V</b>	<b>Process</b>	2048 0412C	2086 0412C	2087 0412C	2084 0412C	2085 0412C

## CUSTOMIZED PRODUCT

	Connection	Deflection	Format	Zero position	Rating	Start/end of scale
<b>Example</b>	direct process signal	90° 240°	48 x 48 96 x 96	left left	0 - 200 V 0 - 10 V	0 - 200 V 0 - 400 m3

## ASSOCIATED PRODUCTS



### Accessories

Seal, ring fastener, dial, sleeve, etc.  
page 215

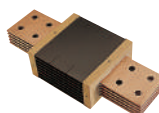

### SHUNTS

1 to 6,000 A  
Vast choice whatever your application.  
page 140



# NORMEUROPE RANGE

Round barrel analog panel meters for high-level operating constraints.



## GENERAL SPECIFICATIONS

**Accuracy class:** 1.5 (+/- 1.5% of full scale)

**Mounting:** on front panel by means of studs or ring fastener

- **Maximum panel thickness:** 8 mm

### Materials:

Barrel: self-extinguishing ABS

Front panel: self-extinguishing polycarbonate

Additional casing: Bakelite base, ABS cover

**Operating position:** calibration for vertical position ( $\pm 10^\circ$ )

### Overloads:

Voltmeter and frequency meter

- 1.2 Un permanent
- 2 Un for 5 s

Ammeter

- 1.3 In permanent
- 10 In for 5 s

## REFERENCE STANDARDS

**Reference standard:** IEC 60051-1, IEC 60051-2, IEC 60051-9

**EMC:** IEC 61326-1, IEC 61326-2-1, EN 61000-4

**Safety rules:** IEC 61010-1, IEC 61010-2-030

- Category III

**Resistance to vibrations:** IEC60051 – IEC 60068-2-6

- 10 to 55 Hz, +/- 15 mm

**Resistance to mechanical shocks:** IEC 60068-2-27

- 15 g

**Degree of protection:** IEC 60529

## USER SECTORS



Industry



Energy generation



Energy transmission & distribution



Nuclear



Compliant with the latest applicable standards



Large choice of functions, formats, ratings, IPs and options



Attractive design and easy to read



- **Customer references:** EDF, on-board naval applications, energy generation and distribution
- **Designed for demanding applications:** nuclear, military, naval
- **Long product life span**

• See table "Mounting mode – Ingress Protection (IP)"  
**Degree of protection provided by the enclosure:** IEC60529

- IK08 on the cover

**Climatic withstand:** IEC 60051-1, IEC 60051-9

- Calibration temperature: 23°C +/- 2°C
- Rated operating temperature: 23°C +/- 10°C
- Operating temperature limits: -25°C to + 60 °C
- Storage temperature: -25°C to + 70°C
- Relative humidity: 25% to 95%
- Atmospheric pressure: up to 2,000 m – 795 hPa

## DIMENSIONS AND PANEL DRILLING SPECIFICATIONS

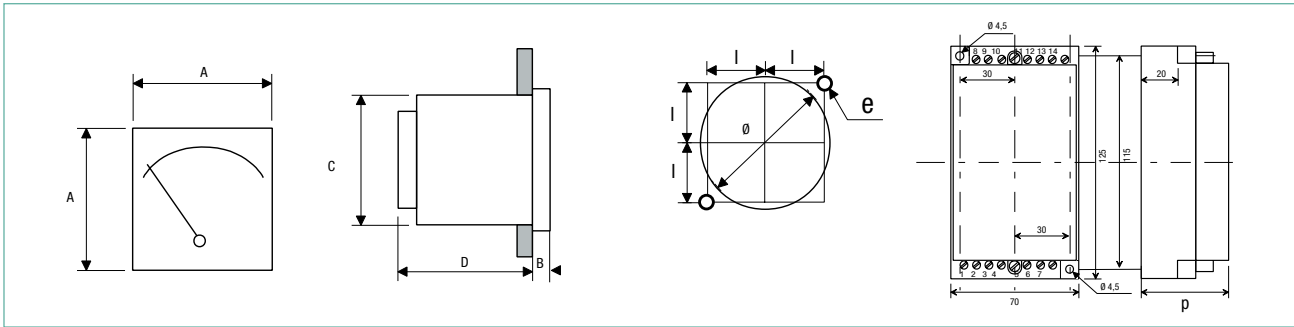

A x A Format	Panel meter			Additional unit	
	48 x 48	72 x 72	96 x 96	A	B
B (mm)	8	13	14		
C (mm)	diam. 44	diam. 55	diam. 80		
D 90° DEFLECTION or blades (mm)	46	29 if 20 A max. 39 if 25 A et plus			
D 250° DEFLECTION (mm)	58	71	71		
Ø (mm)	45	58	88		
l (mm)	20.25	26.5	34		
e (mm)	Ø3.5	Ø4.5	Ø4.5	P=48	P=122
Weight (kg)	0.20	0.25	0.30	0.30	0.70
Terminal	M4 and Faston up to 20 A. M6 for higher values			cage for 4 mm <sup>2</sup> wire	

## MECHANICAL SPECIFICATIONS

Format	Deflection	90°			240°			
		48 x 48	72 x 72	96 x 96	48 x 48	72 x 72	96 x 96	
<b>Mounting and front-panel tightness outside standard <sup>(1)</sup></b>								
Panel meter standard: IP 40 front panel								
Casing: IP 20								
360° panel meters: always 4 studs								
Option	Ring fastener	IP 40 front panel	drill 48 mm	drill 58 mm	drill 88 mm	drill 48 mm	drill 58 mm	drill 88 mm
Option	Reinforced mounting + gasket	IP 52 front panel	4 studs M2,5	4 studs M4	4 studs M4	4 studs M2,5	4 studs M4	4 studs M4
Option	Watertight (Reset, front panel)	+ IP54 seal front panel		4 studs M4	4 studs M4	4 studs M2,5	4 studs M4	4 studs M4
Option	Watertight (Reset, front/rear panels)	+ IP55 product panels		4 studs M4	4 studs M4	4 studs M2,5	4 studs M4	4 studs M4
<b>Production of non-standard dials (after feasibility approval)</b>								
	Dial markings on request		■	■	■	■	■	■
	Color markings		■	■	■	■	■	■
	Color zones		■	■	■	■	■	■
	Black background, white markings		■	■	■	■	■	■
	Double scale			■	■	■	■	■

(1) IPXY, where X is the level of protection against penetration by solid bodies and Y is the level of protection against penetration by liquid

## ACCESSORIES

Format	Deflection	90°			240°		
		48 x 48	72 x 72	96 x 96	48 x 48	72 x 72	96 x 96
	Front-panel sealed gasket	2465 001	2314 375	2314 376	2465 001	2314 375	2314 376
	Fitting clip (without seal)	2328 558	2302 348	2307 086	2328 558	2302 348	2307 086
	Standard or previous dial	■	■	■	■	■	■
	Customized dial (on request)	■	■	■	■	■	■
	Flask of antistatic liquid						9030 00676
	Insulation sleeve for terminals						ACCQ 1001

# AC AMMETER



## 90° DEFLECTION

### Standard-scale model

**Accuracy class:** 1.5

**Measuring component:** moving iron  
50-60-400 Hz and rectified moving coil  
50-10,000 Hz

Pseudo-linear scale (moving iron)

Interchangeable dial, except 144 x 144

**Consumption:** 1 VA

### Motor-scale model

**Accuracy class:** 1.5

**Measuring component:** moving iron 50-60-400 Hz

Pseudo-linear scale

Calibrated 0-In up to 2/3 of deflection, with overload zone beyond. Interchangeable 90° dial, except 144 x 144 format

**Consumption:** 1 VA

## 250° DEFLECTION

### Standard-scale model

**Accuracy class:** 1.5

**Measuring component:** rectified moving coil  
50-10,000 Hz

Linear scale. With additional unit «A» in 48 x 48 format

**Consumption:** 0.5 VA

### Motor-scale model

**Accuracy class:** 1.5

**Measuring component:** rectified moving coil  
50-10,000 Hz

Linear scale

Calibrated 0-In up to 2/3 of deflection, with overload zone beyond

With additional unit "A" in 48 x 48 format

**Consumption:** 0.5 VA

## FEASIBILITY LIMITS

		Deflection			90°			250°		
		48 x 48	72 x 72	96 x 96	48 x 48	72 x 72	96 x 96			
<b>Direct connection</b>										
Standard scale	moving iron	0.5 to 15 A			0.5 to 50 A					
	moving coil				1 mA to 25 A			1 mA to 25 A		
Motor scale	moving iron 2 to 6 In	0.5 to 12 A			0.5 to 40 A					
	moving coil 2/3/5 In							0.5 to 20 A		
<b>Connection on CT</b>										
Standard scale	moving iron				1 to 6.6 A					
	moving coil				1.3 to 6.6 A			1.2 to 6.6 A		
Motor scale	moving iron 2 to 6 In				1 A and 5 A					
	moving coil 2/3/5 In							1 A and 5 A		

## DIRECT CONNECTION

		Deflection			90° (iron. 50 Hz)			250°		
		48 x 48	72 x 72	96 x 96	48 x 48	72 x 72	96 x 96			
<b>Rating</b>	<b>Scale In</b>									
5 A	0-5 A	■	A90A 0302	A90A 0502	■	■	■			
10 A	0-10 A	■	A90A 0303	A90A 0503	■	■	■			
20 A	0-20 A		A90A 0304	A90A 0504		■	■			
30 A	0-30 A		A90A 0305	A90A 0505						
50 A	0-50 A		A90A 0307	A90A 0507						
<b>Rating</b>	<b>Scale 3 In</b>									
5 A	0-5/15 A	■		A90A 0533	■	■	■			
10 A	0-10/30 A	■		A90A 0534	■	■	■			
20 A	0-20/60 A			A90A 0535		■	■			
30 A	0-30/90 A			A90A 0536						
40 A	0-40/120 A			A90A 0537						
<b>Rating</b>	<b>Scale 5 In</b>									
5 A	0-5/25 A					■	■			

## CUSTOMIZED PRODUCT

	Instrument	Deflection/Motor scale	Format	Scale	Rating CT ratio	Frequency
Examples	Complete meter	90° iron 250° coil	72 x 72 96 x 96	0-15/90A 0-1.25/2.5 kA	direct 15A CT 1250/5 A	50 Hz 60 Hz

# CONNECTION ON CT 5 A

Deflection		Iron. 50 Hz - 90°			Iron 50 Hz - 90°			250°		
		Panel meter and dial separate			Complete panel meter			Complete panel meter		
Format		48 x 48	72 x 72	96 x 96	48 x 48	72 x 72	96 x 96	48 x 48	72 x 72	96 x 96
Rapport	Scale	Panel meter only								
		A90A 0487	A90A 0486	A90A 0485						
		Dial only								
CT	1,3 In									
5/5 A	0-6,5 A	CADR 0136	CADR 0702	CADR 0492	■	■	■	■	■	■
10/5 A	0-13 A	CADR 0137	CADR 0703	CADR 0493	■	■	■	■	■	■
15/5 A	0-20 A	CADR 0138	CADR 0704	CADR 0494	■	■	■	■	■	■
20/5 A	0-26 A	CADR 0111	CADR 0461	CADR 0441	A90A 0211	A90A 0311	A90A 0511	■	■	A250 0611
25/5 A	0-32,5 A	CADR 0110	CADR 0701	CADR 0486	■	■	■	■	■	■
30/5 A	0-40 A	CADR 0112	CADR 0462	CADR 0442	A90A 0212	A90A 0312	A90A 0512	■	■	A250 0612
40/5 A	0-52 A	CADR 0113	CADR 0463	CADR 0443	A90A 0213	A90A 0313	A90A 0513	■	■	A250 0613
50/5 A	0-65 A	CADR 0114	CADR 0464	CADR 0444	A90A 0214	A90A 0314	A90A 0514	■	■	A250 0614
60/5 A	0-80 A	CADR 0115	CADR 0465	CADR 0445	A90A 0215	A90A 0315	A90A 0515	■	■	A250 0615
75/5 A	0-100 A	CADR 0116	CADR 0466	CADR 0446	A90A 0216	A90A 0316	A90A 0516	■	■	A250 0616
100/5 A	0-130 A	CADR 0117	CADR 0467	CADR 0447	A90A 0217	A90A 0317	A90A 0517	■	■	A250 0617
125/5 A	0-165 A	CADR 0118	CADR 0468	CADR 0448	A90A 0218	A90A 0318	A90A 0518	■	■	A250 0618
150/5 A	0-200 A	CADR 0119	CADR 0469	CADR 0449	A90A 0219	A90A 0319	A90A 0519	■	■	A250 0619
200/5 A	0-260 A	CADR 0120	CADR 0470	CADR 0450	A90A 0220	A90A 0320	A90A 0520	■	■	A250 0620
250/5 A	0-325 A	CADR 0121	CADR 0471	CADR 0451	A90A 0221	A90A 0321	A90A 0521	■	■	A250 0621
300/5 A	0-400 A	CADR 0122	CADR 0472	CADR 0452	A90A 0222	A90A 0322	A90A 0522	■	■	A250 0622
400/5 A	0-520 A	CADR 0123	CADR 0473	CADR 0453	A90A 0223	A90A 0323	A90A 0523	■	■	A250 0623
500/5 A	0-650 A	CADR 0124	CADR 0474	CADR 0454	A90A 0224	A90A 0324	A90A 0524	■	■	A250 0624
600/5 A	0-800 A	CADR 0125	CADR 0475	CADR 0455	A90A 0225	A90A 0325	A90A 0525	■	■	A250 0625
750/5 A	0-1 kA	CADR 0126	CADR 0476	CADR 0456	A90A 0226	A90A 0326	A90A 0526	■	■	A250 0626
800/5 A	0-1,04 kA	CADR 0135	CADR 0481	CADR 0487	■	■	■	■	■	■
1000/5 A	0-1,3 kA	CADR 0127	CADR 0477	CADR 0457	A90A 0227	A90A 0327	A90A 0527	■	■	A250 0627
1250/5 A	0-1,65 kA	CADR 0128	CADR 0478	CADR 0458	A90A 0228	A90A 0328	A90A 0528	■	■	A250 0628
1500/5 A	0-2 kA	CADR 0129	CADR 0479	CADR 0459	A90A 0229	A90A 0329	A90A 0529	■	■	A250 0629
2000/5 A	0-2,6 kA	CADR 0130	CADR 0480	CADR 0460	A90A 0230	A90A 0330	A90A 0530	■	■	A250 0630
2500/5 A	0-3,25 kA	CADR 0131	CADR 0482	CADR 0488	■	A90A 0331	A90A 0531	■	■	■
3000/5 A	0-4 kA	CADR 0132	CADR 0483	CADR 0489	■	A90A 0332	A90A 0532	■	■	■
4000/5 A	0-5,2 kA	CADR 0133	CADR 0484	CADR 0490	■	■	■	■	■	■
5000/5 A	0-6,5 kA	CADR 0134	CADR 0485	CADR 0491	■	■	■	■	■	■
Rapport	Scale	Panel meter only								
		A90A 0107	A90A 0106	A90A 0105						
		Dial only								
CT	3 In									
5/5 A	0-5/15 A	CADR 0139	CADR 0169	CADR 0059	A90A 0239	A90A 0339	A90A 0539	■	■	A250 0639
10/5 A	0-10/30 A	CADR 0140	CADR 0170	CADR 0060	A90A 0240	A90A 0340	A90A 0540	■	■	A250 0640
15/5 A	0-15/45 A	CADR 0141	CADR 0171	CADR 0061	A90A 0241	A90A 0341	A90A 0541	■	■	A250 0641
20/5 A	0-20/60 A	CADR 0142	CADR 0172	CADR 0062	A90A 0242	A90A 0342	A90A 0542	■	■	A250 0642
25/5 A	0-25/75 A	CADR 0167	CADR 0168	CADR 0087	■	■	■	■	■	■
30/5 A	0-30/90 A	CADR 0143	CADR 0173	CADR 0063	A90A 0243	A90A 0343	A90A 0543	■	■	A250 0643
40/5 A	0-40/120 A	CADR 0144	CADR 0174	CADR 0064	A90A 0244	A90A 0344	A90A 0544	■	■	A250 0644
50/5 A	0-50/150 A	CADR 0145	CADR 0175	CADR 0065	A90A 0245	A90A 0345	A90A 0545	■	■	A250 0645
60/5 A	0-60/180 A	CADR 0146	CADR 0176	CADR 0066	A90A 0246	A90A 0346	A90A 0546	■	■	A250 0646
75/5 A	0-75/225 A	CADR 0147	CADR 0177	CADR 0067	A90A 0247	A90A 0347	A90A 0547	■	■	A250 0647
100/5 A	0-100/300 A	CADR 0148	CADR 0178	CADR 0068	A90A 0248	A90A 0348	A90A 0548	■	■	A250 0648
125/5 A	0-125/375 A	CADR 0149	CADR 0179	CADR 0069	A90A 0249	A90A 0349	A90A 0549	■	■	A250 0649
150/5 A	0-150/450 A	CADR 0150	CADR 0180	CADR 0070	A90A 0250	A90A 0350	A90A 0550	■	■	A250 0650
200/5 A	0-200/600 A	CADR 0151	CADR 0181	CADR 0071	A90A 0251	A90A 0351	A90A 0551	■	■	A250 0651
250/5 A	0-250/750 A	CADR 0152	CADR 0182	CADR 0072	A90A 0252	A90A 0352	A90A 0552	■	■	A250 0652
300/5 A	0-300/900 A	CADR 0153	CADR 0183	CADR 0073	A90A 0253	A90A 0353	A90A 0553	■	■	A250 0653
400/5 A	0-0,4/1,2 kA	CADR 0154	CADR 0184	CADR 0074	A90A 0254	A90A 0354	A90A 0554	■	■	A250 0654
500/5 A	0-0,5/1,5 kA	CADR 0155	CADR 0185	CADR 0075	A90A 0255	A90A 0355	A90A 0555	■	■	A250 0655
600/5 A	0-0,6/1,8 kA	CADR 0156	CADR 0186	CADR 0076	■	A90A 0356	A90A 0556	■	■	■
750/5 A	0-0,75/2,25 kA	CADR 0157	CADR 0187	CADR 0077	■	A90A 0357	A90A 0557	■	■	■
800/5 A	0-0,80/2,4 kA	CADR 0158	CADR 0188	CADR 0078	■	■	■	■	■	■
1000/5 A	0-1/3 kA	CADR 0159	CADR 0189	CADR 0079	■	■	■	■	■	■
1200/5 A	0-1,2/3,6 kA	CADR 0160	CADR 0190	CADR 0080	■	■	■	■	■	■
1500/5 A	0-1,5/4,5 kA	CADR 0161	CADR 0191	CADR 0081	■	■	■	■	■	■
2000/5 A	0-2/6 kA	CADR 0162	CADR 0192	CADR 0082	■	■	■	■	■	■
2500/5 A	0-2,5/7,5 kA	CADR 0163	CADR 0193	CADR 0083	■	■	■	■	■	■
3000/5 A	0-3/9 kA	CADR 0164	CADR 0194	CADR 0084	■	■	■	■	■	■
4000/5 A	0-4/12 kA	CADR 0165	CADR 0195	CADR 0085	■	■	■	■	■	■
5000/5 A	0-5/15 kA	CADR 0166	CADR 0196	CADR 0086	■	■	■	■	■	■

## ASSOCIATED PRODUCTS



### Accessories

Seal, ring fastener, dial, sleeve, etc.  
page 223



### Current transformers

Cable primary, busbar primary, closed core or split core, etc.  
page 108

# AC VOLTMETER



## 90° DEFLECTION

### Standard-scale model

Accuracy class: 1.5  
 Measuring component: moving iron  
 50-60-400 Hz and rectified moving coil 50-10,000 Hz  
 Pseudo-linear scale (iron)  
 Interchangeable dial  
**Consumption:** 4.5 VA max

### Extended-scale model

**Accuracy class:** 1.5  
 Measuring component: moving iron  
 50-60-400 Hz  
 Pseudo-linear scale  
**Consumption:** 2.5 VA  
 With additional "A" unit for 48 x 48 format with 250° and 90° if value < 100 V

## 250° DEFLECTION

### Standard-scale model

Accuracy class: 1.5  
 Measuring component: rectified moving coil 50-10,000 Hz  
 Linear scale  
 Impedance 1 kΩ/V

### Extended-scale model

Accuracy class: 1.5  
**Measuring component:** rectified moving coil  
 50-10,000 Hz  
 Linear scale Impedance 2 kΩ/V  
 With additional "A" unit in 48 x 48 format with 250° and 90° if value < 100 V

## FEASIBILITY LIMITS

Format	Deflection			250°		
	48 x 48	72 x 72	96 x 96	48 x 48	72 x 72	96 x 96
<b>Direct connection</b>						
Scale Vn ; 1.2	moving iron			15 to 600 V		
Vn	moving coil			1.5 to 600 V		
Extended scale	10-15, 20-30, 40-70, 75-120, 80-120, 90-130, 90-140, 100-150, 200-300, 400-600 V			40-70, 80-120, 96-144, 100-150, 400-600 V		
<b>Connection on VT</b>						
Scale according to client specifications	from Un / 100/√3 V			from Un / 100/√3 V		

## DIRECT CONNECTION

Format	Rating	Scale Vn	Deflection			90°(Iron. 50Hz)			250°		
			48 x 48	72 x 72	96 x 96	48 x 48	72 x 72	96 x 96	48 x 48	72 x 72	96 x 96
15 V	0-15 V		■	■	■	■	■	■	■	■	
30 V	0-30 V		■	■	■	■	■	■	■	■	
60 V	0-60 V		■	■	■	■	■	■	■	■	
150 V	0-150 V		■	■	■	■	■	■	■	■	
250 V	0-250 V					A90V 0266	A90V 0366	A90V 0566		A250 0666	
300 V	0-300 V					A90V 0268	A90V 0368	A90V 0568		A250 0668	
500 V	0-500 V					A90V 0267	A90V 0367	A90V 0567		A250 0667	
<b>Rating Extended scale</b>											
230 V	150-260		■	■				A90V 0588	■	■	
400 V	300-450		■	■				A90V 0589	■	■	

## CONNECTION ON VT

Format	Rating	Scale	Deflection			90°(Iron. 50Hz)			250°		
			48 x 48	72 x 72	96 x 96	48 x 48	72 x 72	96 x 96	48 x 48	72 x 72	96 x 96
VT/100 V	0-1.2 Vn		■	■	■	■	■	■	■	■	
VT/100/√3 V	0-1.2 Vn		■	■	■	■	■	■	■	■	

## CUSTOMIZED PRODUCT

	Connection	Deflection / Measure	Format	Scale	Rating/VT ratio	Frequency
Examples	direct on VT	90° iron 250°	72 x 72 96 x 96	Vn 1.2 Vn	15 V 20 / 0.11 Kv	50 Hz 60 Hz

## ASSOCIATED PRODUCTS



### Accessories

Seal, ring fastener, dial, sleeve, etc.  
 page 225



# FREQUENCY METER



**Pointer frequency meter**

**90° - 250° DEFLECTION**

**Accuracy class:** 0.5 of  $F_n$

**Measuring component:** moving coil and frequency converter

**Linear scale**

**Operating range:** 0.80  $U_n$  to 1.15  $U_n$

With additional "A" unit for 48 x 48 format with 250° and 90° if value < 100 V

**Consumption:** 3 VA

## FEASIBILITY CONSTRAINTS

Voltage 57.7 V to 440 V and frequency 50 to 400 Hz

Format	Deflection	90°	
		72 x 72	96 x 96
100 V	45-55 Hz	■	■
	55-65 Hz	■	■
230 V	45-55 Hz	■	FA90 0681
	55-65 Hz	■	■
400 V	45-55 Hz	■	FA90 0682
	55-65 Hz	■	■

Format	Deflection	250°	
		72 x 72	96 x 96
100 V	45-55 Hz	■	■
	55-65 Hz	■	■
230 V	45-55 Hz	■	■
	55-65 Hz	■	■
400 V	45-55 Hz	■	■
	55-65 Hz	■	■

## CUSTOMIZED PRODUCT

	Deflection	Format	Voltage	Measurement range
Examples	90°	72 x 72	100 V	45-55 Hz
	250°	96 x 96	110 V	45-65 HZ

## ASSOCIATED PRODUCTS



**Accessories**

Seal, ring fastener, dial, sleeve, etc.  
page 225

# WATTMETER VARMETER



## 90° - 250° DEFLECTION

**Linear scale**, measurement range according to client specifications (apparent power kVA, active power kW or reactive power kvar)

2 mA moving coil analog panel meter (other ratings on request) associated with a T82 or TRIAD measurement transducer (see Transducers chapter)

**Accuracy class: 1.5**

## TRANSDUCERS TO BE USED

The transducer used with the analog panel meter will be selected in the “TRANSDUCERS” chapter of this catalog.



T82N



TRIAD 2

## CUSTOMIZED PRODUCT

	Network	Deflection	Format	Frequency	CT ratio	Direct / VT	Voltage or VT ratio	Scale beginning	Scale ending	Transducer model
Examples	Active single Reactive balanced three-phase 3 wires	90° 250°	72 x 72 96 x 96	50 Hz 60 Hz	1000/5 A 400/5 A	Direct VT	230 V 20 kV / 115 V	0 kW -12 MVA <sub>r</sub>	250 kW +12 MVA <sub>r</sub>	TRIAD T82

## ASSOCIATED PRODUCTS

### Accessories



Seal, ring fastener, dial, sleeve, etc.  
page 225



### TRIAD 2

Digital transducers  
1 to 4 analog outputs. Class 0.1.  
page 156



### Current transformers

Cable primary, busbar primary, closed core or split core, etc.  
page 108



### Les T82N

Convertisseurs à technologie analogiques.  
page 172

# PHASEMETERS



## 90° - 250° DEFLECTION

### Scale in $\cos \varphi$

2 mA moving coil analog panel meter (other ratings on request) associated with a T82 or TRIAD measurement transducer (see Transducers chapter)

**Accuracy class: 2.5**

## TRANSDUCERS TO USE

The transducer to use with the analog panel meter must be chosen in the “TRANSDUCERS” chapter of this catalog.



T82N



TRIAD 2

## CUSTOMIZED PRODUCT

	Network	Deflection	Format	Frequency	CT secondary	Voltage	Measurement range	Transducer model
Examples	Single Unbalanced three-phase	250° 360°	72 x 72 96 x 96	50 Hz 60 Hz	5 A 1 A	230 V 440 V	0.5 cap / 1/0.5 -1 / 0 / +1	TRIAD T82

## ASSOCIATED PRODUCTS



### Accessories

Seal, ring fastener, dial, sleeve, etc.  
page 225



### Current transformers

Cable primary, busbar primary, closed core or split core, etc.  
page 108



### TRIAD 2

Digital transducers  
1 to 4 analog outputs. Class 0.1.  
page 156

# SYNCHRONIZERS

## Vibrating-reed double frequency meter



**Accuracy class:** 0.5  
**Consumption:** 3 VA  
**Operating range:** 0.8 to 1.15 Un  
**Measuring component:** vibrating reed in field of coil  
**Amplitude of vibration:** proportional to  $V^2$

### FEASIBILITY LIMITS

Voltage 57.7 V to 440 V

		2 rows of 9 segments	
Format		72 x 72	96 x 96
48-52 Hz	Frequency		
	Voltage		
	100/ $\sqrt{3}$ V	■	■
	100 V		FL12 0677
58-62 Hz	230 V	■	FL12 0678
	400 V	■	FL12 0679
	100/ $\sqrt{3}$ V	■	■
	100 V	■	■
	230 V	■	■
	400 V	■	■

### CUSTOMIZED PRODUCT

	Format	Frequency	Voltage
Examples	96 x 96 72 x 72	48-52 Hz 58-62 Hz	100/ $\sqrt{3}$ V 415 V

### ASSOCIATED PRODUCTS



#### Accessories

Seal, ring fastener, dial, sleeve, etc.  
 page 225

## Differential Voltmeter



**90° DEFLECTION - 250°**  
**Accuracy class:** 2.5  
**Consumption:** 0.5 VA per circuit  
**Frequency:** 50-60 Hz  
**Measurement range:** 0.75 to 1.25 Un  
**Additional unit** "B"

### FEASIBILITY LIMITS

Voltage 57.7 V to 440 V, other measurement ranges

		Deflection		90°	
Format		72 x 72		96 x 96	
Voltage Un	100/ $\sqrt{3}$ V	■		■	
	100 V	■			BASS 0591
	230 V	■			BASS 0592
	400 V	■			BASS 0593

		Deflection		250°	
Format		72 x 72		96 x 96	
Voltage Un	100/ $\sqrt{3}$ V	■		■	
	100 V	■			■ C250 069
	230 V	■		■	
	400 V	■		■	

### CUSTOMIZED PRODUCT

	Deflection	Format	Voltage	Measurement range
Examples	90° 250°	72 x 72 96 x 96	100 V 100/ $\sqrt{3}$ V	±25% ±50%

METERS AND POWER MONITORS  
 NETWORK MONITORING FROM LV TO HV  
 CURRENT TRANSFORMERS AND SHUNTS  
 TRANSDUCERS  
 PANEL METERS AND SYNCHROCOUPLER  
 AUXILIARY RELAYS  
 CIVILIAN AND MILITARY NAVAL APPLICATIONS  
 SERVICES AND TRAINING

# DC AMMETER



## 90° DEFLECTION

**Accuracy class:** 1.5

(option class 1 except 48 x 48)

**Measuring component:** Moving coil

Linear scale

Interchangeable dial, except 144 x 144

**Voltage drop:** 60 mV for rating  $\geq$  50 mA  
variable for rating  $<$  50 mA

## 240° DEFLECTION

**Accuracy class:** 1.5

**Measuring component:** Moving coil

Linear scale

**Voltage drop:** 100 mV for rating  $\geq$  10 mA  
variable for rating  $<$  10 mA

## FEASIBILITY LIMITS

Format	Deflection	90°			250°		
		48 x 48	72 x 72	96 x 96	48 x 48	72 x 72	96 x 96
Direct connection	Zero position, left or central	50 mA to 20 A			50 $\mu$ A to 75 A		
Process signal connection	Zero position set	4-20 mA 10-50 mA 2-10 mA			4-20 mA 10-50 mA 2-10 mA 4-23,2 mA		
Shunt connection	Zero position, left or central	50 mV 60 mV 100 mV 120 mV 150 mV 300 mV 360 mV			50 mV 60 mV 100 mV 120 mV 150 mV 300 mV		

## DIRECT CONNECTION

Format	Deflection	90°			240°		
		48 x 48	72 x 72	96 x 96	48 x 48	72 x 72	96 x 96
Rating	Scale						
5 A	0-5 A	■	■	■	■	■	■
10 A	0-10 A	■	■	■	■	■	■
15 A	0-15 A	■	■	■			
25 A	0-25 A		■	■			

## CONNECTION ON 100 mV SHUNT

Format	Deflection	90°			240°		
		48 x 48	72 x 72	96 x 96	48 x 48	72 x 72	96 x 96
Shunt	Scale 1,2 In						
5 A	0-6 A	■	■	■	■	■	■
10 A	0-12 A	■	■	■	■	■	■
15 A	0-18 A	■	■	■	■	■	■
20 A	0-24 A	■	■	■	■	■	■
25 A	0-30 A	■	■ C90S 1403	■ C90S 1503	■	■	■
30 A	0-36 A	■	■	■	■	■	■
40 A	0-48 A	■	■	■	■	■	■
50 A	0-60 A	■	■ C90S 1406	■ C90S 1506	■	■	■
60 A	0-72 A	■	■	■	■	■	■
75 A	0-90 A	■	■ C90S 1408	■ C90S 1508	■	■	■
100 A	0-120 A	■	■ C90S 1409	■ C90S 1509	■	■	■
125 A	0-150 A	■	■	■	■	■	■
150 A	0-180 A	■	■ C90S 1411	■ C90S 1511	■	■	■
200 A	0-240 A	■	■	■	■	■	■
250 A	0-300 A	■	■ C90S 1413	■ C90S 1513	■	■	■
300 A	0-360 A	■	■	■	■	■	■
400 A	0-480 A	■	■	■	■	■	■
500 A	0-600 A	■	■ C90S 1416	■ C90S 1516	■	■	■
600 A	0-720 A	■	■	■	■	■	■
1000 A	0-1200 A	■	■	■	■	■	■

## CUSTOMIZED PRODUCT

	Connection	Deflection	Format	Zero position	Rating	Beginning/end of scale
Examples	direct signal process	90° 250°	72 x 72 96 x 96	left set	60 A 4-20 mA	0-60 A 0-1500 RPM

## ASSOCIATED PRODUCTS



### Accessories

Seal, ring fastener, dial, sleeve, etc.  
page 225

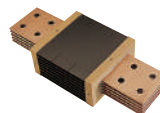

### SHUNTS

1 to 6,000 A  
Vast choice whatever your application.  
page 140

# DC VOLTMETER



## 90° DEFLECTION

**Accuracy class:** 1.5

(option class 1 except 48 x 48)

**Measuring component:** Moving coil

Linear scale

**Consumption:**

1 mA for  $U_n \geq 500$  mV

5 mA for  $U_n < 500$  mV

## 250° DEFLECTION

**Accuracy class:** 1.5

**Measuring component:** Moving coil

Linear scale

**Consumption:**

1 mA for  $U_n \geq 1$  V

2 mA for  $U_n \geq 1$  V (central zero)

5 mA for  $U_n < 1$  V

## FEASIBILITY LIMITS

Deflection		90°			250°		
Format		48 x 48	72 x 72	96 x 96	48 x 48	72 x 72	96 x 96
Direct connection	Zero position, left or central	50 mV to 600 V			50 mV to 600 V		
Process signal connection	Zero position, left	from 50 mV			from 50 mV		
	Set zero position				1-5 V 2-10 V		

## DIRECT CONNECTION

Deflection		90°			240°		
Format		48 x 48	72 x 72	96 x 96	48 x 48	72 x 72	96 x 96
<b>Rating</b>							
15 V		■	■	■	■	■	■
30 V		■	■ C90S 1425	■ C90S 1525	■	■	■
60 V		■	■ C90S 1426	■ C90S 1526	■	■	■
75 V		■	■	■	■	■	■
150 V		■	■ C90S 1428	■ C90S 1528	■	■	■ C250 1928
300 V		■	■	■	■	■	■

## CUSTOMIZED PRODUCT

	Deflection	Format	Zero position	Rating	Beginning/end of scale
Examples	90° 250°	72 x 72 48 x 48	left central	75 V 400 V	0 - 75 V 400 V - 0 - 400 V

## ASSOCIATED PRODUCTS



### Accessories

Seal, ring fastener, dial, sleeve, etc.

page 225

# COHO RANGE

Hour meters for totalling the operating time of machines or equipment for control and maintenance.



## GENERAL SPECIFICATIONS

**Reference standard:** NFC 42310

**Display:** without reset function, white on black background, decimals in red Height of digits: 4 mm  
AC and DC capacity: 99,999.99 h  
Operating indicator: scrolling 1/100 h every 36 s

**Motor in Vac/Vdc:** pulse + electronic counter

**Consumption:**

0.5 VA in 24 Vac/dc,  
1.5 VA in 48 Vac/dc,  
2 VA in 110/230 Vac,  
6 VA in 400 Vac

**Operating range:**

Voltage Vac: -15% +10%  
Frequency: ± 5 Hz  
Voltage Vdc: ± 20%  
Insulation: double

**Dielectric test voltage:**

5.5 kV - 50 Hz - 1 min

**Environment:**

Operating temperature: -10°C to +60°C  
Relative humidity: < 95% at +45°C

**Protection rating on front panel:**

standard: IP50 / variant: IP55

**Electromagnetic compatibility**

(emission and immunity): EN 61326-1

**Mounting:**

Standard version: elastic joint

**IP55 version:** joint + strap

**Weight:** 180 g

**Connection:** 6.35 Faston clips + terminal covers included

### Panel drilling

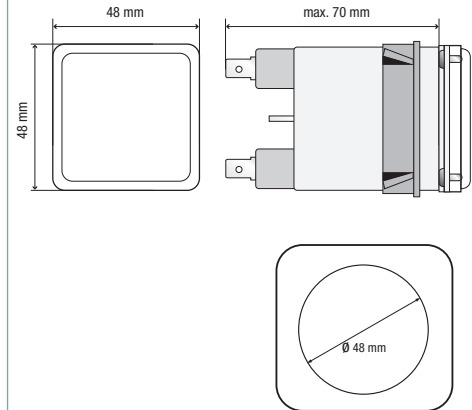

- For harsh environments
- High-reliability range

Format		48 x 48 (IP50)	48 x 48 (IP55)
Frequency	Voltage		
50 Hz	24 V	COHO 0606	COHO 1606
	48 V	COHO 0607	COHO 1607
	110 V	COHO 0608	COHO 1608
	230/400 V	COHO 0610	COHO 1610
60 Hz	24 V	COHO 0627	COHO 1627
	48 V	COHO 0628	COHO 1628
	110 V	COHO 0629	COHO 1629
	230/400 V	COHO 0631	COHO 1631
DC	24 V	COHO 0604	COHO 1604
	48 V	COHO 0605	COHO 1605

# LK RANGE

Hour meters (7 or 8 digits) for totalling the operating time of machines or equipment for control and maintenance.

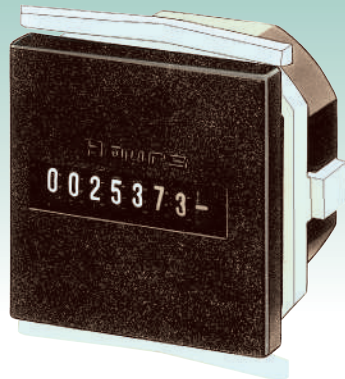

## GENERAL SPECIFICATIONS

**Display:** without reset function, white on black background, decimals in red  
Height of digits: 4 mm

AC capacity: 99,999.99 h

DC capacity: 999,999.99 h

Operating indicator in Vac: ridged roll

Operating indicator in Vdc: continuous scrolling 1/100h every 36 s

**Motor in Vac:** synchronous

**Motor in Vdc:** step-by-step

**Consumption:**

Vdc:  $\leq 750$  mW

Vac:  $\leq 1.65$  VA

**Insulation:** single

**Dielectric test voltage:** 2 kV - 50 Hz - 1 min

**Operating range:**

Voltage Vac:  $\pm 10\%$

Frequency:  $\pm 10\%$

Voltage Vdc:  $\pm 10\%$

**Environment:**

Operating temperature:  $-15^{\circ}\text{C}$  to  $+50^{\circ}\text{C}$

Relative humidity:  $< 95\%$  at  $+45^{\circ}\text{C}$

**Protection rating on front panel:** IP52

**Mounting:** self-locking flange

**Weight:** 50 g

**Connection:** 6.35 lugs or Faston clips

## USER SECTORS



Industry

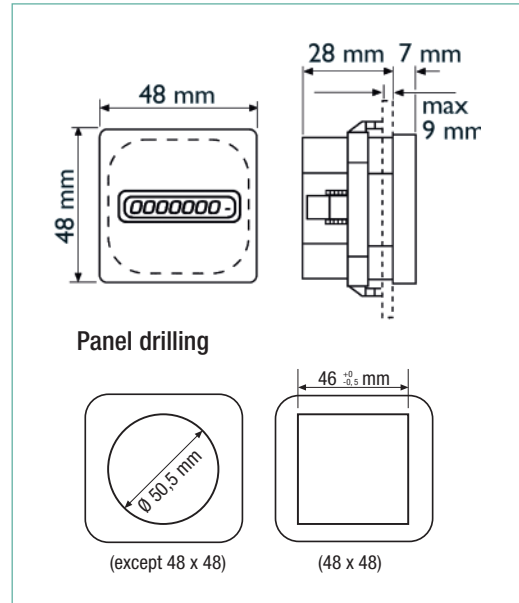

- Easy to install
- Economical

Format		48 x 48	55 x 55	72 x 72
Frequency	Voltage			
	24 V	LK4N 001N	LK5N 001N	LK7N 001N
50 Hz	48 V	LK4N 003N	LK5N 003N	LK7N 003N
	115 V	LK4N 005N	LK5N 005N	LK7N 005N
	230 V	LK4N 007N	LK5N 007N	LK7N 007N
	400 V	LK4N 009N	LK5N 009N	LK7N 009N
	24 V	LK4N 002N	LK5N 002N	LK7N 002N
60 Hz	48 V	LK4N 004N	LK5N 004N	LK7N 004N
	115 V	LK4N 006N	LK5N 006N	LK7N 006N
	230 V	LK4N 008N	LK5N 008N	LK7N 008N
	400 V	LK4N 010N	LK5N 010N	LK7N 010N
	10-30 V	LK4N 011N	LK5N 011N	LK7N 011N
Continu	36-80 V	LK4N 012N	LK5N 012N	LK7N 012N
	110-130 V	LK4N 013N	LK5N 013N	LK7N 013N
Front panel only			LK5N 0000	LK7N 0000

METERS AND POWER MONITORS

NETWORK MONITORING FROM LV TO HV

CURRENT TRANSFORMERS AND SHUNTS

TRANSDUCERS

PANEL METERS AND SYNCHROCOUPLER

AUXILIARY RELAYS

CIVILIAN AND MILITARY NAVAL APPLICATIONS

SERVICES AND TRAINING



**CRITICAL AUXILIARY RELAYS**

# AUXILIARY RELAYS



- 240 **OVERVIEW OF THE RANGE**
- 242 **SELECTION GUIDE**

METERS AND  
POWER MONITORS

NETWORK MONITORING  
FROM LV TO HV

CURRENT TRANSFORMERS  
AND SHUNTS

TRANSDUCERS

PANEL METERS AND  
SYNCHROCOUPLER

AUXILIARY RELAYS

CIVILIAN AND MILITARY  
NAVAL APPLICATIONS

SERVICES AND TRAINING

# AUXILIARY RELAYS

## INSTANTANEOUS RELAYS

### MONOSTABLE



**MONOSTABLE**  
catalog 906130145



**MONOSTABLE**  
forcibly guided contacts

### BISTABLE



**BISTABLE**  
catalog 906130145

### FAST-ACTING MONOSTABLE AND BISTABLE



Fast-acting monostable  
and bistable

## TIME-DELAY RELAYS / LOGIC FUNCTIONS



**TIME DELAY**  
on pick-up or drop-out  
(logic function)



**TIME DELAY**  
with forcibly  
guided contacts

## MEASUREMENT RELAYS



## SOCKETS AND ACCESSORIES



Rear connection, front connection, screw connection, Faston connection, blade connection, spring connection: various sockets are available. Chauvin Arnoux Energy® also proposes a complete range of accessories: locking spring, bar-mounting strap, bar for panel mounting, DIN-rail fitting, safety blank, etc.

catalogue 906130145



TO SEE ALL OUR RANGES,  
CHECK OUT OUR  
RELAYS CATALOG

## USER SECTORS



Energy generation



Energy transmission & distribution



Nuclear

## THE REFERENCE FOR INDUSTRIAL RELAYS

The French measuring instrument designer and manufacturer **Chauvin Arnoux Group** is acknowledged as a major player in the electrical sector and is consolidating its position on the physical measurement market. At the heart of electrical measurement activities, it plays a crucial role in the implementation of energy management and control systems.

Its scope covers applications as diverse as basic measurement of electrical parameters, network monitoring – from energy production through to distribution to end-users – **safety of property CO and people, equipment maintenance and energy supply quality.**

## THREE BRANDS, ONE BUSINESS

Inside the Chauvin Arnoux Group, **Chauvin Arnoux Energy** offers the electrical industry and the tertiary sector all the fixed electrical switchboard equipment necessary to measure, control and monitor the power distribution chain. Drawing on more than sixty years' experience, the group proposes its **expertise in control relays for severe environments** such as the nuclear industry,

petrochemicals or rail transport. It is also backed by the expertise and know-how of the Group's Italian subsidiary, **AMRA Spa**, which has been making electro-mechanical relays since 1975.

With its integration of relays made by **RIA – MTI**, a well-known manufacturer since 1957, Chauvin Arnoux Energy is now a major player in the world of control relays.

## APPLICATIONS AND CONFORMITY

Nuclear power, petrochemicals, rail transport, industry: there are relays for every sector of activity. Some are covered by particularly strict standards so that they can handle the constraints of the environment in which they will be operating:

- Temperature withstand
- Fire resistance
- Resistance to corrosive gases
- Shock resistance
- Vibration resistance
- Dust resistance
- Contact materials
- Type of magnetic circuit
- Surface treatments and finishes

## SPECIFIC STANDARDS AND CECOIFICATIONS

### RAIL

NF-F 16-101, NF-F 16-102 (materials), NF-F 62002, CF 62003, UIC 616-0, IEC 61810-3 and EN 45545-2, Relays approved by SNCF and RATP: F-OK B, F-OK TBAO, F-OK TBOR

### ENERGY

Category K3 (seismic stresses), EDF qualification for use in nuclear power stations. Chauvin Arnoux Energy relays are recommended by EDF for EPRs (European Pressurized Reactors).

EDF: HM-2A / 03 / 111 / ENEL: LV15/1, LV15/2 / LV16/1, LV16/2, LV16/3, LV16/4, LV16/5

METERS AND POWER MONITORS

NETWORK MONITORING FROM LV TO HV

CURRENT TRANSFORMERS AND SHUNTS

TRANSDUCERS

PANEL METERS AND SYNCHROCOUPLER

AUXILIARY RELAYS

CIVILIAN AND MILITARY NAVAL APPLICATIONS

SERVICES AND TRAINING

# SELECTION GUIDE



Energy generation



Nuclear

Depending on products



Power transmission



Rolling stock

Depending on products



Fixed railway installation



Shipbuilding



Petroleum industry



Heavy industry



Model	Monostable instantaneous	Bistable (latching)	Contacts guidés	Fast-acting(*)	Time delay	Contacts	In	Notes	Rolling stock equipment (***)	Nuclear
RCM	■					2 CO	10 A	Compact		
RDM	■					4 CO	10 A	Compact		
RGM	■					4 CO	12 A	High breaking capacity (**)		
RMMX	■					8 CO	10 A	Multi-contact, compact		
RMM	■					8-12-20 CO	12 A	High breaking capacity, multi-contact		
POK-POKS	■					2 CO	5-10 A	Compact		
BIPOK-BIPOKS	■					4 CO	5-10 A	Compact		
TRIPOK-TRIPOKS	■					6 CO	5-10 A	Compact		
QUADRIPOK	■					8 CO	10 A	Compact		
ESAPOK	■					12 CO	10 A	Compact		
OK	■					4-8-12 CO	10 A	High breaking capacity		
OKB184	■					4 CO	10 A	High breaking capacity, K3-qualified		
RE3000	■					4 CO	10 A	K3-qualified		
FOKB	■					4 CO NC-NO	13 A	High breaking capacity, NF F62-002		
RCG	■		■			2 CO	10 A	Forcibly guided contacts, type A, EN61810-3		
RDG	■		■			4 CO	10 A	Forcibly guided contacts, type A, EN61810-3		
RGG Previous name RGMZX	■		■			4 CO	10 A	High breaking capacity, forcibly guided contacts, type A, EN61810-3		
RMGX	■		■			8 CO	10 A	High breaking capacity, forcibly guided contacts, type A, EN61810-3		
RGB		■				3-4 CO	12 A	High breaking capacity		
RMBX		■				7-8 CO	10 A	Multi-contact		
RMB		■				7-11-19 CO	10 A	High breaking capacity, multi-contact, common negative		
OKBA		■				4-8 CO	10 A	High breaking capacity		
RGMVX	■			■		4 CO	10 A	Operating time < 8 ms		
RMMV/X	■			■		8-12 CO	10 A	Operating time < 8 ms for compact models, otherwise < 10 ms		
RGR	■			■		2 CO	2 A	Operating time < 3 ms		



Energy generation



Nuclear

Depending on products



Power transmission



Rolling stock

Depending on products



Fixed railway installation



Shipbuilding



Petroleum industry





Heavy industry



Model	Monostable instantaneous	Bistable (latching)	Contacts guidés	Fast-acting(*)	Time delay	Contacts	In	Notes	Rolling stock equipment (***)	Nuclear
RGMV	■			■		4 (or NC)	10 A	Operating time < 8 ms		
RMMV	■			■		8 (CO or NC)	10 A	Operating time < 6 ms		
RMMZ11/13	■			■		8 CO	10 A	Operating time < 13 ms		
RGBV		■		■		4 CO	10 A	Operating time < 10 ms		
RMBV		■		■		8-12 CO	10 A	Operating time < 10 ms		
RGBZ10/11		■		■		3-4 CO	12 A	Operating time < 12 ms		
RMBZ30		■		■		7 CO	10 A	Operating time < 18 ms		
RV LV16	■			■		6 (NO or NC)	5 A	Operating time < 6 ms		
RDT					■	4 CO	10 A	Time delay on pick-up or drop-out		
RDL - RGL					■	2 CO	10 A	Flasher		
RDTE15/16					■	4 CO	10 A	Delay on drop-out, adjustable duration, no Vaux		
RGTO					■	1 CO	5 A	Delay on drop-out, adjustable duration, no Vaux		
TMM					■	4 CO	10 A	Multifunction relay, 10 functions		
TM - TMS Previous names OK-T-MF/S					■	4 CO	5-10 A	Time delay on pick-up or drop-out		
TOK					■	4 CO	10 A	High breaking capacity, time delay on pick-up or drop-out		
OKR					■	4 CO	5 A	Time delay on pick-up or drop-out		
OKT					■	4 CO	5 A	Time delay on pick-up or drop-out		
UTM					■	-	-	Static time delay unit		
TOK-L					■	4 CO	10 A	High breaking capacity, flasher		
TOK-FP					■	4 CO	10 A	High breaking capacity, flasher		
OKRE-L					■	4 CO	5 A	Flasher		
OKRE-FP					■	4 CO	5 A	Flasher		
CLE					■	4 CO	5 A	Flasher		
RGK			■		■	4 CO	12 A	Forcibly guided contacts, type A, EN61810-3		
MOK-V2	■					2 CO	3 A	Measuring relay, voltage		

# SELECTION GUIDE

TERMINAL	FRONT Connection			REAR CONNECTION			PCB
	SCREW	SPRING CLAMP	SCREW	DOUBLE FASTON	SPRING CLAMP		
MOUNTING	PLATE-WALL / DIN RAIL	PLATE-WALL	PLATE-WALL / DIN RAIL	FLUSH MOUNTING		SOLDER	
 RELAY MODEL				 SOCKET MODEL			
<b>RCM</b>	PAVC081	-	PAIR085	PRVC081	PRDC081	-	PRCC080
<b>RDM</b>	PAVD161	-	PAIR165	PRVD161	-	-	PRCD161
<b>RGM</b>	PAVG161	-	-	PRVG161	PRDG161	-	-
<b>RMMX</b>	96IP20-I DIN	-	PAIR320	-	ADF4	PRIR320	-
<b>RMM (8 cts)</b>	PAVM321	-	-	PRVM321	PRDM321	-	-
<b>RMM (12 cts)</b>	PAVM481	-	-	PRVM481	PRDM481	-	-
<b>RMM (20 cts)</b>	PAVM801	-	-	PRVM801	PRDM801	-	-
<b>POK-POKS</b>	50IP20-I DIN	50L	PAIR080	53IL	ADF1	PRIR080	65
<b>BIPOK-BIPOKS</b>	48BIP20-I DIN	48BL	PAIR160	43IL	ADF2	PRIR160	65
<b>TRIPOK-TRIPOKS</b>	78BIP20-I DIN	78BL	PAIR240	73IL	ADF3	PRIR240	-
<b>QUADRIPOK</b>	96IP20	96BL	PAIR320	43IL	ADF4	PRIR320	65
<b>ESAPOK</b>	156IP20	78BL	PAIR480	73IL	ADF6	PRIR480	-
<b>OK / OKB184</b>	48BIP20-I DIN	48BL	PAIR160	43IL	ADF2	-	65
<b>RE3000</b>	EVV3100	EVL3100*	-	ERV3100	ERL320*	ERL310*	-
<b>FOKB</b>	-	-	-	-	84F*	-	-
<b>RCG</b>	50IP20-I DIN	-	PAIR080	-	ADF1	PRIR080	65
<b>RDG</b>	48BIP20-I DIN	-	PAIR160	-	ADF2-BIPOK	PRIR160	65
<b>RGG</b>	48BIP20-I DIN	-	PAIR160	43IL	ADF2	PRIR160	65
<b>RMGX</b>	96IP20-I DIN	-	PAIR320	-	ADF4-E1	PRIR321	-
<b>RGB</b>	PAVG161	-	-	PRVG161	PRDG161	-	-
<b>RMBX</b>	96IP20-I DIN	-	PAIR320	-	ADF4	PRIR320	-
<b>RMB (7 cts)</b>	PAVM321	-	-	PRVM321	PRDM321	-	-
<b>RMB (11 cts)</b>	PAVM481	-	-	PRVM481	PRDM481	-	-
<b>RMB (19 cts)</b>	PAVM801	-	-	PRVM801	PRDM801	-	-
<b>OKBA</b>	48BIP20-I DIN	48BL	PAIR160	43IL	ADF2	PRIR160	65

\*EVL3100: Faston front connection

\*ERL320: double blade

\*ERL310: single blade

\*84F: Single Faston

OLD SOCKET NAME	NEW SOCKET NAME
50	50IP20-I DIN
48B	48IP20-I DIN
78B	78IP20-I DIN
50BF	50L
48BF	48BL
78BF	78BL
65F	65

## USER SECTORS



Energy generation





Energy transmission & distribution



Nuclear

### FRONT Connection

### REAR CONNECTION

TERMINAL	SCREW		SPRING CLAMP	SCREW	DOUBLE FASTON	SPRING CLAMP	PCB
MOUNTING	PLATE-WALL / DIN RAIL	PLATE-WALL	PLATE-WALL / DIN RAIL		FLUSH MOUNTING		SOLDER
 RELAY MODEL				 SOCKET MODEL			
<b>RGMVX</b>	48BIP20-I DIN	-	PAIR160	-	ADF2	PRIR160	-
<b>RMMVX</b>	96IP20-I DIN	-	PAIR320	-	ADF4	PRIR320	-
<b>RMMVx1/7</b>	PAVM481	-	-	PRVM481	PRDM481	-	-
<b>RGR</b>	PAVG161	-	-	PRVG161	PRDG161	-	-
<b>RGMV</b>	PAVG161	-	-	PRVG161	PRDG161	-	-
<b>RMMV</b>	PAVM321	-	-	PRVM321	PRDM321	-	-
<b>RMMZ11 / 13</b>	PAVM321	-	-	PRVM321	PRDM321	-	-
<b>RGBZ10 / 11</b>	PAVG161	-	-	PRVG161	PRDG161	-	-
<b>RMBZ30</b>	PAVM321	-	-	PRVM321	PRDM321	-	-
<b>RV LV16</b>	78BIP20-I DIN	-	PAIR240	73IL	ADF3	PRIR240	-
<b>RDT</b>	PAVD161	-	PAIR165	PRVD161	-	-	PRCD161
<b>RDL</b>	PAVD161	-	PAIR165	PRVD161	-	-	PRCD161
<b>RGL</b>	PAVG161	-	-	PRVG161	PRDG161	-	-
<b>RDTE15 / 16</b>	PAVD161	-	PAIR165	PRVD161	-	-	PRCD161
<b>RGTO</b>	PAVG161	-	-	PRVG161	PRDG161	-	-
<b>TMM</b>	48BIP20-I DIN	48BL	PAIR160	43IL	ADF2	PRIR160	65
<b>TM - TMS</b>	48BIP20-I DIN	48BL	PAIR160	43IL	ADF2	PRIR160	65
<b>TOK</b>	48BIP20-I DIN	48BL	PAIR160	43IL	ADF2	PRIR160	65
<b>OKR</b>	48BIP20-I DIN	48BL	PAIR160	43IL	ADF2	PRIR160	65
<b>OKT</b>	48BIP20-I DIN	48BL	PAIR160	43IL	ADF2	PRIR160	65
<b>UTM</b>	48BIP20-I DIN	48BL	PAIR160	43IL	ADF2	PRIR160	65
<b>TOK-L</b>	48BIP20-I DIN	48BL	PAIR160	43IL	ADF2	PRIR160	65
<b>TOK-FP</b>	48BIP20-I DIN	48BL	PAIR160	43IL	ADF2	PRIR160	65
<b>OKRE-L</b>	48BIP20-I DIN	48BL	PAIR160	43IL	ADF2	PRIR160	65
<b>OKRE-FP</b>	48BIP20-I DIN	48BL	PAIR160	43IL	ADF2	PRIR160	65
<b>CLE</b>	48BIP20-I DIN	48BL	PAIR160	43IL	ADF2	PRIR160	65
<b>RGK</b>	48BIP20-I DIN	-	PAIR160	-	ADF2	PRIR160	-
<b>MOK-V2</b>	48BIP20-I DIN	48BL	PAIR160	43IL	ADF2	PRIR160	65

For more details, please see the socket datasheets.

METERS AND POWER MONITORS

NETWORK MONITORING FROM LV TO HV

CURRENT TRANSFORMERS AND SHUNTS

TRANSDUCERS

PANEL METERS AND SYNCHROCOUPLER

AUXILIARY RELAYS

CIVILIAN AND MILITARY NAVAL APPLICATIONS

SERVICES AND TRAINING



# CIVILIAN **AND** MILITARY NAVAL APPLICATIONS



- 248 MECHANICAL ANEMOVANE
- 250 PTU SENSOR PRESSURE, TEMPERATURE AND HUMIDITY
- 252 SEAWATER TEMPERATURE SENSOR
- 254 WIND REPEATER MULTIFONCTION
- 256 DATA CONCENTRATION AND COMMUNICATION UNIT

METERS AND POWER MONITORS

NETWORK MONITORING FROM LV TO HV

CURRENT TRANSFORMERS AND SHUNTS

TRANSDUCERS

PANEL METERS AND SYNCHROCOUPLER

AUXILIARY RELAYS

CIVILIAN AND MILITARY NAVAL APPLICATIONS

SERVICES AND TRAINING

# MECHANICAL ANEMOVANE

818 323

This sensor measures the wind speed and direction.

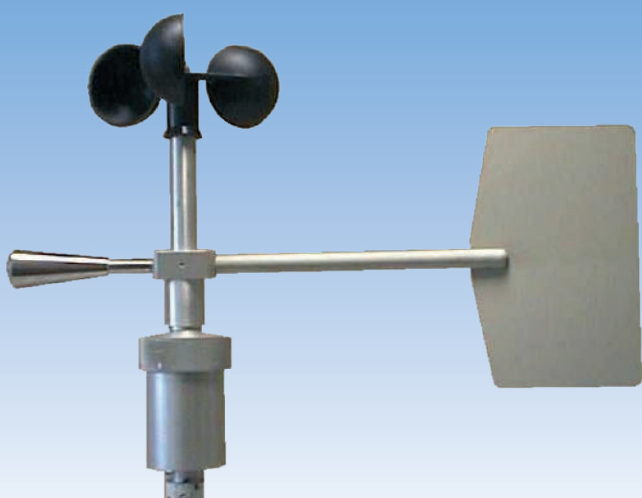

## GENERAL SPECIFICATIONS

These combined sensors measure the wind speed and direction. They are installed at various locations on the foremast, on the port and starboard sides.

They comprise a microcontroller central processing unit handling measurement acquisition and processing, as well as adjustment and modification of the instrument's specific parameters.

The digital data are delivered via the MODBUS protocol.

Access to the modifications of the parameter settings is provided on a PC via a USB-RS485 interface and the associated software.

## USER SECTORS



Naval applications



- **Compact**  
easy integration
- **Rugged**  
for harsh Naval applications environments
- **Simplified maintenance**  
interchangeable parts

Anemometer		Vane
Type of sensor	Period meter	Synchro-resolver
Measurement range	0 to 60.00 m/s	0 to 359.9 °
Resolution	0.01 m/s	0.1 °
Discrimination threshold	less than 0.5 m/s, 0.5% end of scale +/- 0.3 m/s	
Accuracy		+/- 2 °
Acquisition time	500 ms	500 ms

Environmental specifications	
Temperature	-20 to +70°C in operation
Pressure	700 mbar < P < 1.300 mbar
Hygrometry	10 to 95% RH
Roll, pitch, list, trim	No effect

Mechanical specifications	
Overall dimensions	690 x 390 mm
Body material	AU4G aluminum alloy
Counterweight material	Stainless steel
Weight	1.6 kg
Ingress protection	IP20

Electrical specifications	
Power supply	DC voltage from 12 to 35 V=
Consumption	25 mA at 28 V=
Connection	Output via cable gland and 5-contact cable

METERS AND POWER MONITORS

NETWORK MONITORING FROM LV TO HV

CURRENT TRANSFORMERS AND SHUNTS

TRANSDUCERS

PANEL METERS AND SYNCHROCOUPLER

AUXILIARY RELAYS

CIVILIAN AND MILITARY NAVAL APPLICATIONS

SERVICES AND TRAINING

# PTU SENSOR

## PRESSURE, TEMPERATURE AND HUMIDITY

818 390

This sensor measures air pressure, temperature and humidity.



### GENERAL SPECIFICATIONS

This sensor comprises a microcontroller central processing unit handling measurement acquisition and processing, as well as adjustment and modification of the instrument's specific parameters.

The digital data are delivered via the MODBUS protocol.

Access to the modifications of the parameter settings is provided on a PC via a USBRS485 interface and the associated software.

### USER SECTORS



Naval applications



- **Compact**  
easy integration
- **Rugged**  
for harsh Naval applications environments
- **Simplified maintenance**  
interchangeable parts

### Specifications of the serial link

<b>Type</b>	Isolated RS 485 as per EIA 485
<b>Mode</b>	Half Duplex
<b>Protocol</b>	MODBUS RTU
<b>Speed</b>	9.600 bauds (1.200 to 38.400 Bd)
<b>Transmission format</b>	1 start bit - 8 data bits 1 parity bit (even, odd or none) - 1 stop bit

	Pressure	Dew point	Humidity	Temperature
<b>Type of sensor</b>	Piezoresistive		Polymer capacitor	Pt 1000 Ohms
<b>Measurement range</b>	850 to 1.100 hPa	40 +80 °C	0 to 100% RH	-20 °C to +70 °C
<b>Resolution</b>	0.1 hPa	0.1 °C	0.1 %	0.1 °C
<b>Accuracy</b>	+/- 0.1 % end of scale +/- 0.1 hPa	Digital calculation	+/- 4% RH	0.4 % end of scale +/- 0.1 °C
<b>Coefficient</b>	100 ppm/K		100 ppm/K	100 ppm/K
<b>Acquisition time</b>	1.4 seconds	1.4 seconds	1.4 seconds	1.4 seconds

### Environmental specifications

<b>Temperature</b>	-20 to +70°C in operation
<b>Pressure</b>	700 mbar < P < 1.300 mbar
<b>Hygrometry</b>	10 to 95% RH
<b>Roll, pitch, list, trim</b>	No effect

### Mechanical specifications

<b>Overall dimensions</b>	200 x 200 x 580 mm
<b>Shelter material</b>	ABS
<b>Ingress protection</b>	IP20
<b>Weight</b>	~ 3 kg

### Electrical specifications

<b>Power supply</b>	DC voltage from 12 to 35 V=
<b>Consumption</b>	45 mA at 28V=
<b>Connection</b>	Output via cable gland and 5-contact cable

# SEAWATER

## TEMPERATURE SENSOR

### A25300 SP

This sensor measures the temperature of seawater.



#### GENERAL SPECIFICATIONS

The seawater temperature needs to be measured because the ship's engines are cooled with seawater.

This sensor comprises a microcontroller central processing unit handling measurement acquisition and processing, as well as the settings and modification of the instrument's specific operating parameters.

Parameter modifications can be accessed on a PC by means of a USB-RS485 interface and the associated software.

#### USER SECTORS



Naval applications



- **Compact**  
easier integration
- **Complete**  
thermowell supplied
- **Fast**  
SOURIAU quarter-turn plug for easy mounting/removal

Specifications of the measurement channel	
Analog input	Pt100 (3 wires)
Measurement range	-100 °C to +300 °C
Resolution	0.1 °C
Accuracy	$2.10^{-4}$ reading +0.3°C
Acquisition time	200 ms

Specifications of the serial link	
Type	Isolated RS 485 compliant with EIA 485
Mode	Half Duplex
Protocole	MODBUS RTU
Speed	9600 bauds (1200 à 38400 Bd)
Format de transmission	<ul style="list-style-type: none"> <li>• 1 start bit</li> <li>• 8 data bits</li> <li>• 1 parity bit (even, odd or without)</li> <li>• 1 stop bit</li> </ul>

Environmental specifications	
Temperature	-20 to +70°C in operation
Pressure	700 mbar < P < 1300 mbar
Hygrometry	10 to 95% RH
Roll, pitch, list, trim	No effect

Mechanical specifications	
Overall dimensions	239 x 84 x 140 mm
Body material	Aluminum
Probe material	Stainless steel
Thermowell material	Cupro Aluminum
Weight	~ 0.95 Kg

Electrical specifications	
Power supply	DC voltage from 12 to 35 V=
Consumption	60 mA at 28V=
Connection	Output via HE10 connector, plug supplied (plate 1)

# WIND REPEATER

## MULTIFUNCTION

### A25400

This repeater formats and distributes the wind data.



#### USER SECTORS



Naval  
applications



- **Particularly easy to read:**  
6.5-inch LCD VGA color screen
- **High performance**  
advanced algorithms comparing the data from all the sensors to provide a reliable, pertinent indication of the different winds.
- **Complete**  
recovery of the data from the wind network sensors.

#### GENERAL SPECIFICATIONS

Measurements of the meteorological parameters such as the winds, air pressure, humidity and temperature, as well as the navigation data, are essential for ship operation.

This unit comprises a microcontroller central processing unit handling the processing, display and distribution of the data, as well as adjustment and modification of the instrument's specific operating parameters.

Access to the modifications of the parameter settings is provided on a PC via a USB-RS485 interface and the associated software.

Specifications of the RS 485 serial link		Specifications of the Ethernet link
Type	Electrically-isolated RS 485 as per EIA 485	Ethernet
Mode	Half Duplex	Full Duplex
Protocol	MODBUS RTU	Multicast
Speed	9.600 bauds (1.200 to 34.800 Bd)	100 Mbps
Transmission format	1 start bit - 8 data bits 1 parity bit (even, odd or none) - 1 stop bit	
Polling cycle	500 ms for all the sensors	

Specifications of the two RS 422 serial links	
Type	Electrically-isolated RS 422 as per EIA 422
Mode	Half Duplex
Protocole	NMEA183 / specific
Speed	1.200 to 34.800 Bd
Format de transmission	1 start bit - 8 data bits 1 parity bit (even, odd or none) - 1 stop bit
Polling cycle	Every 500 ms

Environmental specifications	
Temperature	0 to +50°C in operation
Pressure	700 mbar < P < 1.300 mbar
Hygrometry	10 to 95% RH
Roll, pitch, list, trim	No effect

Mechanical specifications	
Overall dimensions	229 x 202 x 194 mm
Casing material	Sheet steel
Ingress protection	IP20
Weight	3 kg

Electrical specifications	
Power supply	DC voltage from 19 to 35 V=
Consumption	400 mA at 28 V=
Protection	0.6 A time-delayed fuse / 250 V
Connection	Socket J1: 8-pin for 422 link, supplied with plugs Socket J2: 8-pin for RS485 wind BUS, supplied with plugs Socket J3: RJ45 Ethernet link, supplied with plugs

# DATA CONCENTRATION AND COMMUNICATION UNIT A25412-E

This unit provides the interface between the digitized wind network, the navigation BUS and the external subscribers using the wind data.



## GENERAL SPECIFICATIONS

The CCC unit collects the wind data available on the BUS and interfaces with the navigation data from the ship. The CCC stores the processed data and then distributes them on several digital links via various protocols.

It comprises a 32-bit microcontroller central processing unit handling management of the communication links and processing of the information, as well as adjustment and modification of the instrument's specific operating parameters.

Access to the modifications of the parameter settings is provided on a PC via a USB-RS485 interface and the associated software.

## USER SECTORS



Naval  
applications



- **Rugged**  
metal unit integrated in a waterproof cast aluminum enclosure
- **Versatile**  
multiple input and output connections (interfacing with the navigational computers and the wind network and distribution via 4 subscriber links according to various programmable protocols)
- **Complete**  
protocol gateway and data logger function

Internal Wind BUS serial link		Navigation BUS serial link
Type	Electrically-isolated RS 485 as per EIA 485	Electrically-isolated RS 422 as per EIA 422
Mode	Half Duplex	Half Duplex
Protocol	MODBUS RTU slave	Specific
Speed	9.600 bauds (1.200 to 34.800 Bd)	1.200 to 34.800 Bd
Transmission format	1 start bit - 8 data bits 1 parity bit (even, odd or none) - 1 stop bit	1 start bit - 8 data bits 1 parity bit (even, odd or none) - 1 stop bit

4 Subscriber serial links		2 Ethernet links
Type	Electrically-isolated RS 485 / RS422	Ethernet
Mode	Half or Full Duplex	Full Duplex
Protocole	NMEA / specific MODBUS RTU	Proprietary (used for transfer of recordings)
Speed	1.200 to 34.800 Bd	100 Mbits
Transmission format	1 start bit - 8 data bits 1 parity bit (even, odd or none) - 1 stop bit	

Environmental specifications	
Temperature	0 to +50°C in operation
Pressure	700 mbar < P < 1.300 mbar
Hygrometry	10 to 95% RH
Roll, pitch, list, trim	No effect

Mechanical specifications	
Overall dimensions	230 x 330 x 110 mm
Body material	Cast aluminum
Ingress protection	IP20
Weight	4.8 kg

Electrical specifications	
Power supply	DC voltage from 19 to 35 V=
Consumption	300 mA at 28V=
Connection	3 cable glands and Amphenol ZN plug
Protection	Fuse



# SERVICES **AND** TRAINING



- 260 SERVICES AND TRAINING
- 262 ORGANIZATION

METERS AND POWER MONITORS

NETWORK MONITORING FROM LV TO HV

CURRENT TRANSFORMERS AND SHUNTS

TRANSDUCERS

PANEL METERS AND SYNCHROCOUPLER

AUXILIARY RELAYS

CIVILIAN AND MILITARY NAVAL APPLICATIONS

SERVICES AND TRAINING

# SERVICES AND TRAINING

Combined know-how in a demanding technological context.



## DESCRIPTION

**Chauvin Arnoux Energy** offers you the benefits of **more than 25 years' experience and know-how in all aspects of electrical energy and in the most demanding business sectors:** energy production, transmission and distribution, major industries, infrastructure, tertiary, etc.

**Chauvin Arnoux Energy** proposes a set of services to help you succeed in your projects, with support from an applications team composed of specialized engineers:

- Basic design studies - Engineering
- Surveys and technical audits
- Commissioning
- Training courses
- On-site and remote maintenance contracts
- Specific development
- Certificate of conformity and verification certificate
- Factory acceptance
- Repairs - After-Sales service



- **More than 25 years' experience**
- **Multiple areas of expertise**
- **A dedicated team of applications engineers**
- **Service provided all over the world**

## BASIC DESIGN STUDIES - ENGINEERING \_\_\_\_\_

Drafting of technical proposals on the basis of specifications or special technical clauses, visit and on-site technical inspection.

## SURVEYS AND TECHNICAL AUDITS \_\_\_\_\_

Pre-project inspection of the sites to identify the requirements and gather all the technical data.

Size an extension or upgrade of the functional installations.

Find the causes and solutions for your on-site technical problems.

## COMMISSIONING \_\_\_\_\_

Operations in France and abroad to set up the equipment, check its installation and roll out the processing and analysis software. Commissioning includes adjusting the parameter settings of the equipment and related software to ensure that the operator can get the system up and running quickly and easily.

## TRAINING COURSES \_\_\_\_\_

The training services on our equipment and software help to optimize the operation of your installations and make them autonomous so that they can be upgraded.

Chauvin Arnoux Energy, a certified training organization since 1993 - certification no. 11.92.16273.92.

## ON-SITE AND REMOTE MAINTENANCE \_\_\_\_\_

With a maintenance contract, you benefit from:

- a privileged relationship for user assistance
- preventive maintenance
- upgrading of the products and software
- specific on-site assistance
- tailored services sized to match your needs

## SPECIFIC DEVELOPMENTS \_\_\_\_\_

Chauvin Arnoux Energy's engineering and manufacturing resources enable it to develop equipment according to specifications with specific features to meet the requirements of the most demanding applications in the energy sector: tariff meters, high-precision current transformers, etc., for RTE and ENEDIS.

## CERTIFICATE OF CONFORMITY AND VERIFICATION CERTIFICATE \_\_\_\_\_

On request, Chauvin Arnoux Energy can deliver its products with specific certificates:

- The certificate of conformity confirms compliance with the stipulations of an order delivered by the industrial company / supplier as per the NF L 00-015C standard
- The verification certificate establishes a table of the measurement deviations between the equipment and a reference instrument. This document complies with the FDX07-011 documentation booklet

## FACTORY ACCEPTANCE \_\_\_\_\_

The customer or a mandated organization is present during the final tests of the products before shipment. Measurements to check the equipment's accuracy and dielectric tests may be performed. The checks are performed on a unit-by-unit basis or by sampling.

## REPAIRS - AFTER-SALES SERVICE \_\_\_\_\_

Manumasure, a company in the Chauvin Arnoux Group, provides after-sales service for the instruments from the Group's brands, with a particular focus on Chauvin Arnoux Energy products. Manumasure's expertise is backed by dedicated human and technical resources, computerization and traceability of the diagrams, centralized management of replacement parts and metrological traceability to the national standards.

# CHAUVIN ARNOUX ENERGY

## A CERTIFIED TRAINING

ORGANIZATION SINCE 1993

CERTIFICATION NO. 11.92.16273.92

### WE ARE IN THE BEST POSITION TO TRAIN YOU

As a manufacturer, we constantly innovate, developing new technologies which we fully master. This know-how guarantees that we possess thorough knowledge of the environments in which our solutions are installed.

As a measuring equipment manufacturer, we design and produce most of the instruments that we offer and with which you work. This means that we can draw on our comprehensive knowledge of the products to offer you training on our most technical equipment and on the energy information systems which form the foundation of our expertise. Practical exercises and concrete case studies are presented and analyzed so that you quickly learn and adopt the best professional practices, particularly in terms of compliance with the applicable standards and regulations.



### TRAINING CERTIFICATES

For all our training courses which do not lead to a qualification, we test and confirm the knowledge acquired by the trainees by means of a multiple-choice test. If their test results are satisfactory, each trainee is awarded a training certificate.

- Expert training instructors acknowledged in their fields
- Innovative demonstration equipment for easier understanding and handling
- A limited number of participants to ensure high-quality dialog

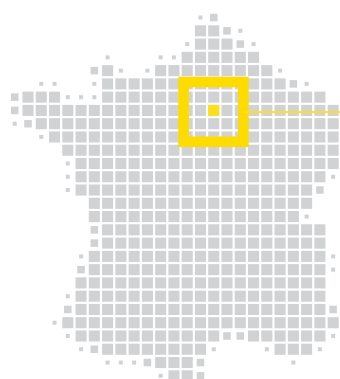

Training courses at the Chauvin Arnoux Group's site in Asnières-sur-Seine



**TRAINING IS A FUNDAMENTAL ADVANTAGE IN ANYONE'S CAREER PATH.**

- To boost skills development
- To gain access to the various levels of qualification
- To obtain professional authorizations



# ABBREVIATIONS

<b>AC</b>	alternating current	<b>mm</b>	millimeter
<b>CL</b>	class	<b>ms</b>	millisecond
<b>CT</b>	current transformer	<b>MV</b>	medium voltage
<b>DC</b>	direct current	<b>NC</b>	"normally closed ("break" relay contact)"
<b>E</b>	energy	<b>NO</b>	"normally open ("make" relay contact)"
<b>Eact</b>	active energy	<b>P</b>	active power (W, kW, MW)
<b>Eapp</b>	apparent energy	<b>PC</b>	personal computer
<b>Ereact</b>	reactive energy	<b>PF</b>	power factor
<b>FS</b>	full scale	<b>PID</b>	proportional integral derivative
<b>g</b>	acceleration of gravity (9.81 m/s <sup>2</sup> )	<b>PPM</b>	parts per million diameter (in mm)
<b>gB</b>	gigabyte	<b>PR</b>	protection rating (often expressed as IP)
<b>HV</b>	high-voltage	<b>Q</b>	reactive power
<b>I</b>	current (A, kA)	<b>R</b>	reading accuracy (in %)
<b>I/o</b>	input/output	<b>RMS</b>	root mean square
<b>IEC</b>	International Electrotechnical Commission	<b>S</b>	apparent power (in VA, kVA, MVA...)
<b>In</b>	nominal or rated current	<b>s</b>	second
<b>IP</b>	protection level	<b>STN</b>	switched telephone network
<b>IR</b>	infrared	<b>TC</b>	thermocouple
<b>K</b>	Kelvin temperature gradient	<b>THD</b>	total harmonic distortion
<b>kB</b>	kilobyte	<b>TRMS</b>	True RMS
<b>LCD</b>	liquid crystal display	<b>U</b>	phase-phase voltage
<b>LED</b>	light-emitting diode	<b>Un</b>	nominal or rated voltage
<b>LV</b>	low voltage	<b>V</b>	phase-neutral voltage
<b>MB</b>	megabyte	<b>VT (or PT)</b>	voltage or potential transformer
<b>min</b>	minute	<b>VN</b>	tension nominale phase-neutre

# INDEX

## A

C ammeter	pages 224
ALTYS	pages 56
Analog panel meter	page 222
Analog transducer	contact us
Analog wind vane	contact us
Anemometer	contact us
APNX	contact us
Automation relay	catalog 906130145

## C

CA 2100	contact us
CA 2150	page 214
CA 3000	contact us
CA 3420	contact us
CDT	contact us
Chart printer	contact us
CLASSIC	page 228
COHO	page 252
Command function indicator	page 250
Configuration software	
for meters and power monitors	page 72
for transducers	page 190
for ENERIUM	page 72
for TRIAD	page 190
for TRIMARAN	contact us
Control relay	contact us
CT short-circuit system	page 158
Current totalizer (CT)	page 149
Current totalizer (transducer)	contact us
Current transformer	page 124
CVAI	contact us

## D

DAA	contact us
DATA LOGGER	page 78
DC ammeter	pages 248
DIGI	contact us
Digital panel meter	page 202
Digital transducer	page 176
Digital wind vane	contact us
Displacement sensor	contact us
weather	contact us
tachometric	contact us
Display software for ENERIUM	page 76
for network analyzer.	page 114
DPM	contact us
DYNAMIC	contact us

## E

E.QUAL PREMIUM SERVER	page 114
E.QUAL PREMIUM	page 114
E.VIEW	page 72
ELINK	page 198
ELOG	page 80
Energy efficiency	page 12
Energy meter	page 12
ENERIUM	page 62, 86
ERDF certification (transformer)	page 152, 153, 154 and 156
EURODIGIT	contact us

## F

F-OK (relay)	catalog 906130145
Frequency meter	page 233, 241
Function relay	catalog 906130145

## H

Hour meter	page 252
------------	----------

## I

Instantaneous relays	catalog 906130145
IPAD	contact us
IPAV	contact us
IPP	contact us

## J

JVM	page 156
JVO	contact us
JVP	contact us
JVR	contact us
JVS	page 138

## L

LK	page 253
LOGIC	contact us
LVDT	contact us

## M

---

Management software for MAP	page 110
MAP	page 100
Maximum demand ammeter	pages 244
Measurement relay	catalog 906130145
Measurement shelter	contact us
MEMO 3	contact us
MEMO 4	contact us
MEMO MD32	page 26
MEMO MD65	page 28
MEMO P200	page 60
MEMO TD80	page 30
Meteorological and special applications	contact us
Meteorology lines	contact us
MID	page 22
MIN	contact us
MODUL M	contact us
MODULIC	contact us
MOK (relay)	catalog 906130145

## N

---

Network analyzer	page 98
Network quality	page 92
NORMEUROPE	page 238

## O

---

Ohmmeter	page 210
OK (relay)	catalog 906130145

## P

---

Panoramic (analog panel meter)	contact us
PC	contact us
Phasemeter	pages 246
POK (relay)	catalog 906130145
Power monitor	pages 62
PRI	contact us
PRISME PC	contact us
PROFIL (analog panel meter)	contact us
Protective relay	catalog 906130145
PRTC	page 158
PTU 100	contact us

## Q

---

QUAL-SRT	page 111
QUAL-SRTc	page 111
QUAL-View	page 112

## R

---

RE (relay)	catalog 906130145
Relay sockets	catalog 906130145
RI (relay)	catalog 906130145

## S

---

SECUREL	contact us
Selection guide	page 256
SÉSAME	contact us
SHEL	page 164
SHMI	page 162
SHMO	page 164
SHUNT	page 160
Submeter	page 12
Switch	contact us
Synchrocoupler	page 216

## T

---

T82N	page 190
Tachometer	page 214
Tariff meter	page 56
TAVID 100.	contact us
TAVID 87	contact us
TC CLIP	page 146
TCR	page 130
TCRO	page 140
TCS	contact us
TD80	page 40
TDA80	page 36
Temperature measurement	page 214
Thermometer	page 214
Time-delay relay	catalog 906130145
TONIC	contact us
Transducer	page 168
TRI500	page 153
TRI700	page 154
TRIAD 2	page 174
TRIADJUST 2	page 188
TRIMARAN	contact us
TSP 2	contact us
TU 100	contact us

## U

---

ULYS flex	page 44
ULYS MCM	page 46
ULYS MD100	page 34
ULYS MD45	page 32
ULYS TD80	page 40
ULYS TDA80	page 36
ULYS TT	page 42
ULYS TTA	page 38

## V

---

Vane anemometer	contact us
Varmeter	page 234
Viewing console	contact us
Voltage totalizer (transducer)	contact us
Voltmeter	page 224

## W

---

Wattmeters	page 232
Wind direction display	contact us
digital (for weather measurement)	contact us
analog wind speed	contact us
digital wind speed	contact us
Wind speed measurement	contact us

## #

---

μDIGI 1	page 204
μDIGI 2	page 208
76/2	page 160
77/2	page 160









## 10 SUBSIDIARIES WORLDWIDE

### AUSTRIA

Chauvin Arnoux Ges.m.b.H  
Slamastrasse 29/2/4  
par Gastgegasse 27  
Tel.: +43 1 61 61 9 61  
vie-office@chauvin-arnoux.at  
www.chauvin-arnoux.at

### CHINA

Shanghai Pu-Jiang  
Enerdis Instruments Co., Ltd.  
3 Floor, 23 Building  
Gemdale Viseen Minhang Technology &  
Industrial Park Project  
1288 lane, Zhongchun Road Minhang  
District, SHANGHAI City.  
Tel.: +86 21 65 21 51 96  
info@chauvin-arnoux.com.cn

### GERMANY

Chauvin Arnoux GmbH  
Ohmstraße 1  
77694 KEHL / RHEIN  
Tel.: +49 07851 99 26-0  
info@chauvin-arnoux.de  
www.chauvin-arnoux.de

### ITALY

AMRA SPA  
Via Sant'Ambrogio, 23  
20846 MACHERIO (MB)  
Tel.: +39 039 245 75 45  
info@amra-chauvin-arnoux.it  
www.chauvin-arnoux.it

### MIDDLE EAST

Chauvin Arnoux Middle East  
PO Box 60-154  
1241 2020 JAL EL DIB  
(Beirut) - LEBANON  
Tel.: +961 1 890 425  
camie@chauvin-arnoux.com  
www.chauvin-arnoux.com

### SCANDINAVIA

CA MÄTSYSTEM AB  
Sjöflygvägen 35  
SE-183 62 TABY  
Tel.: +46 8 50 52 68 00  
info@camatsystem.com  
www.camatsystem.com

### SPAIN

CHAUVIN ARNOUX IBERICA SA  
C/ Roger de Flor N°293 1a Planta  
08025 BARCELONA  
Tel.: +34 902 20 22 26  
info@chauvin-arnoux.es  
www.chauvin-arnoux.es

### SWITZERLAND

CHAUVIN ARNOUX AG  
Moosacherstrasse 15  
8804 AU / ZH  
Tel.: +41 44 727 75 55  
info@chauvin-arnoux.ch  
www.chauvin-arnoux.ch

### UNITED KINGDOM

Chauvin Arnoux Ltd  
Unit 1 Nelson Ct, Flagship Sq  
Shaw Cross Business Pk, Dewsbury  
West Yorkshire - WF12 7TH  
Tel.: +44 1924 460 494  
info@chauvin-arnoux.co.uk  
www.chauvin-arnoux.com

### USA

CHAUVIN ARNOUX INC  
d.b.a AEMC Instruments  
15 Faraday Drive  
Dover - NH 03820  
Tel.: +1 (800) 945-2362  
sales@aemc.com  
www.aemc.com



### FRANCE

#### Chauvin Arnoux Energy

16, rue Georges Besse  
92182 ANTONY Cedex  
Tel.: +33 1 75 60 10 30  
Fax: +33 1 46 66 62 54  
caenergy@chauvin-arnoux.com  
www.chauvin-arnoux-energy.com

### INTERNATIONAL

#### Chauvin Arnoux Energy

16, rue Georges Besse  
92182 ANTONY Cedex  
FRANCE  
Tel.: +33 1 75 60 10 30  
Fax: +33 1 46 66 62 54  
caenergy@chauvin-arnoux.com  
www.chauvin-arnoux-energy.com

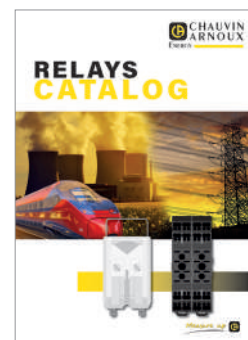

Check out our entire  
automation relays offering  
designed to meet all the  
requirements of many sectors,  
including industry, energy  
and railways.



Measure up